

**International Journal of
Engineering Research and Science & Technology**



ISSN : 2319-5991

www.ijerst.com

Email: editor@ijerst.com or editor.ijerst@gmail.com

ADVANCED DRONE DETECTION WITH CONVOLUTIONAL NEURAL NETWORKS

¹Mr.Y.Balaji,M.Tech,MIAENG, Assistant Professor

²G. Rishitha, ³D. Sravani, ⁴M. Krishnaiah, ⁵ M. Sai Venkata Sudheer

DEPARTMENT OF ELECTRONICS & COMMUNICATION ENGINEERING

CHAITANYA BHARATHI INSTITUTE OF TECHNOLOGY

VIDYA NAGAR, PALLAVOLU (V), PRODDATUR-516360, Y.S.R (Dt.), AP

ABSTRACT

The increasing popularity of unmanned aerial vehicles (UAVs) and drones has brought about significant benefits in various industries. However, it has also raised concerns regarding security and privacy, as malicious actors may exploit these devices for unauthorized surveillance, smuggling, or other illicit activities. This project proposes an innovative approach to address this issue through drone and UAV detection for security applications using deep learning techniques. The proposed system leverages the power of Convolutional Neural Networks (CNNs) and other deep learning models to automatically detect and identify UAVs and drones from visual data captured by surveillance cameras, security systems, or drones equipped with on board cameras. By analyzing the distinct characteristics and patterns of UAVs, such as their unique shapes and flight trajectories, the system can efficiently differentiate them from other objects in the environment. This camera rotates on servo motor, so that it can capture wide area. This proposed project title is Drone and UAV detection for security applications using deep learning a systematic approach to drone detection and classification using deep learning with different modalities. The YOLOv3 object detector is used to detect the moving or still objects. It uses a computer vision-based approach as a reliable solution. The convolution neural network helps to extract features from images and to detect the object with maximum accuracy. The model is trained with a proper dataset and trained for 150 epoch only to detect various types of drones. A convolutional neural network with modern object detection methods shows an excellent approach for real-time detection of drones.

Keywords: Microcontroller, Crystal, LCD, Servo Motor, Camera, Buzzer, Power Source , IOT, Machine Learning Algorithms

I. INTRODUCTION

1.1 INTRODUCTION

Microcontroller are widely used in Embedded Systems products. An Embedded product uses the microprocessor (or microcontroller) to do one task & one task only. A printer is an example of Embedded system since the processor inside it perform one task only namely getting the data and printing it. Although microcontroller is preferred choice for many Embedded systems, there are times that a microcontroller is inadequate for the task. For this reason, in recent years many manufactures of general-purpose microprocessors such as INTEL, Motorola, AMD & Cyrix have targeted their microprocessors for the high end of Embedded market. One of the most critical needs of the embedded system is to decrease power consumptions and space. This can be achieved by integrating more functions into the CPU chips. All the embedded processors have low power consumptions in additions to some forms of I/O, ROM all on a single chip. In higher performance Embedded system, the trend is to integrate more & more function on the CPU chip & let the designer decide which feature he/she wants to use.

1.2 EMBEDDED SYSTEM

Physically, embedded systems range from portable devices such as digital watches and MP3 players to large stationary

installations like traffic lights, factory controllers, or the systems controlling nuclear power plants. Complexity varies from low, with a single microcontroller chip, to very high with multiple units, peripherals and networks mounted inside a large chassis or enclosure

In general, "embedded system" is not an exactly defined term, as many systems have some element of programmability. For example, Handheld computers share some elements with embedded systems such as the operating systems and microprocessors which power them but are not truly embedded systems, because they allow different applications to be loaded and peripherals to be connected. Embedded systems span all aspects of modern life and there are many examples of their use. Telecommunications systems employ numerous embedded systems from telephone switches for the network to mobile phones at the end-user. Computer networking uses dedicated routers and network bridges to route data.

EXAMPLES OF EMBEDDED SYSTEM:

Automated teller. machines (ATMS).
 Integrated system in aircraft and missile.
 Cellular telephones and telephonic switches.
 Computer network equipment, including routers timeservers and firewalls. Computer printers, Copiers. Disk drives (floppy disk drive and hard disk drive). Engine controllers and antilock brake controllers for automobiles.

Home automation products like thermostat, air conditioners sprinkles and security monitoring system. House hold appliances including microwave ovens, washing machines, TV sets DVD layers/recorders. Medical equipment. Measurement equipment such as digital storage oscilloscopes, logic analysers and spectrum analysers. Multimedia appliances: internet radio receivers, TV set top boxes. Small hand-held computer with P1M5 and other applications. Programmable logic controllers (PLC's) for industrial automation and monitoring. Stationary video game controllers.

1.3 CHARACTERISTICS:

Embedded systems are designed to do some specific tasks, rather than be a general-purpose computer for multiple tasks. Some also have real-time performance constraints that must be met, for reasons such as safety and usability; others may have low or no performance requirements, allowing the system hardware to be simplified to reduce costs. Embedded systems are not always standalone devices. Many embedded systems consist of small, computerized parts within a larger device that serves a more general purpose. For example, the Gibson Robot Guitar features an embedded system for tuning the strings, but the overall purpose of the Robot Guitar is, of course, to play music. Similarly, an embedded system in an automobile provides a specific function as a subsystem of the car itself.

The software written for embedded systems is often called firmware, and is usually stored in read- only memory or Flash memory chips rather than a disk drive. It often runs with limited computer hardware resources: small or no keyboard, screen, and little memory.

1.4 MICROPROCESSOR (MP):

A microprocessor is a general-purpose digital computer central processing unit (CPU). Although popularly known as a “computer on a chip” is in no sense a complete digital computer. The block diagram of a microprocessor CPU is shown, which contains an arithmetic and logical unit (ALU), a program counter (PC), a stack pointer (SP), some working registers, a clock timing circuit, and interrupt circuits.

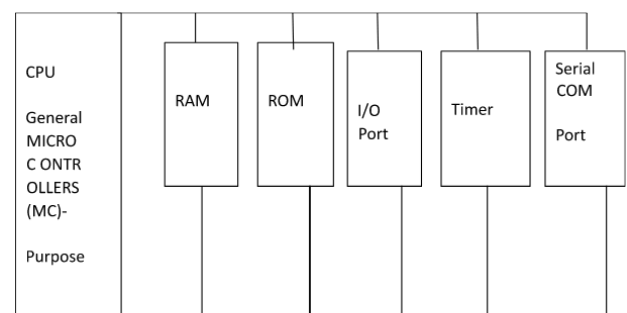

Fig 1.1 Block diagram of microprocessor

1.5 MICROCONTROLLER (MC):

Figure shows the block diagram of a typical microcontroller. The design incorporates all of the features found in micro-processor CPU: ALU, PC, SP, and registers. It also added the other features needed to make a complete

II. LITERATURE SURVEY

2.1 INTRODUCTION

The size of the drone industry expands exponentially to make this gadget reachable to common citizens with cheaper prices. By loading explosives, with them, the drone can easily be converted into killer weapons. Even by pertaining drones, some terror attacks attempts have been reported. As drones are small in size and having small electromagnetic signature makes difficulties for conventional RADAR for detection. A counter mechanism is appraised by industry and the academic world. An object is having a specific structure, texture as well as some specific pattern. In natural environments, it is difficult to differentiate between the same types of objects because of high variation. The performance of an object detector reduces due to the lighting condition, change of appearance, and at what angle the object is facing towards the camera. Most object detector fails when some deformation happens to the object or changes in scale happens to the object. Stopple and background noises add more difficulties to the object detector. In the modern-day object detection, a convolution neural network (CNN) has performed so well that traditional methods have almost vanished from the picture. The best part of the convolution neural network is its ability for extracting features. Based on the convolution neural network, many object

computer: ROM, RAM, parallel I/O, serial I/O, counters, and clock circuit.

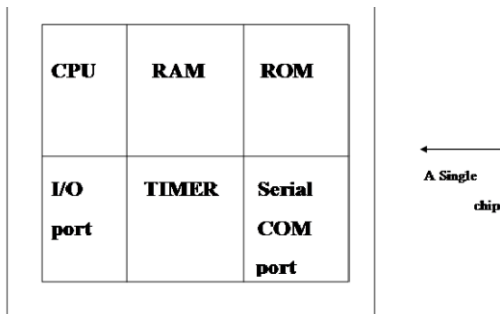

Fig 1.2 Microcontroller

1. 6 COMPARISON BETWEEN MICROPROCESSOR AND MICROCONTROLLER

The microprocessor must have many additional parts to be operational as a computer whereas microcontroller requires no additional external digital parts. The prime use of microprocessor is to read data, perform extensive calculations on that data and store them in the mass storage device or display it. The prime functions of microcontroller is to read data, perform limited calculations on it, control its environment based on these data. Thus the microprocessor is said to be general-purpose digital computers whereas the microcontroller are intend to be special purpose digital controller. Microprocessor need many opcodes for moving data from the external memory to the CPU, microcontroller may require just one or two, also microprocessor may have one or two types of bit handling instructions whereas microcontrollers have many.

detectors come in to picture such as R-CNN, Fast R-CNN, Faster R-CNN, YOLO, SSD, etc. Apart from that, the high-performance GPUs and its easy availability through the use of high-performance cloud computing advanced computational ability. In the success of the neural network, it played a crucial role.

III. PROBLEM STATEMENT

The existing system for drone and Unmanned Aerial Vehicle (UAV) detection in security applications using Deep Learning (DL) represents a pivotal advancement in safeguarding critical infrastructures and public spaces. This system harnesses the capabilities of DL algorithms to autonomously identify and classify drones in real-time. Deep Learning, a subset of artificial intelligence, enables the system to analyze vast amounts of visual data and distinguish between authorized and unauthorized aerial vehicles with high accuracy. The integration of DL in this context allows for the continuous learning and improvement of detection models, adapting to emerging drone technologies and tactics employed by potential threats. The system often relies on a network of sensors, including cameras and radars, to capture data and feed it into the DL algorithms for analysis.

This technology is crucial in enhancing security protocols, as it enables early detection of potential threats posed by drones, ranging from unauthorized surveillance to more malicious activities.

The application of DL in drone detection for

security not only augments response times but also provides a proactive and intelligent layer of defense against evolving security challenges in the airspace.

2.1 EXISTING SYSTEM BLOCK DIAGRAM

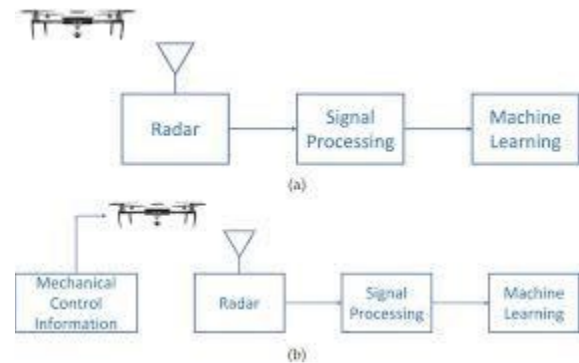

Block diagram of Existing System

2.4 Disadvantages of Existing System:

Limited Accuracy: Traditional methods may struggle to accurately identify drones, especially in cluttered environments.

Range Limitations: Radar and RF detection systems have limited range and may not detect drones at greater distances.

False Positives: Acoustic sensors can be prone to false positives due to environmental noise.

High Cost: Implementing and maintaining these systems can be expensive.

IV. PROPOSED SYSTEM

The Proposed system uses deep learning techniques, specifically Convolutional Neural Networks (CNNs) and the YOLOv3 object detector, to detect and identify drones from visual

data. The system includes a camera mounted on a servo motor to cover a wide area, and it sends alerts through a buzzer and notifications via IoT when a drone is detected.

4.1 BLOCK DIAGRAM OF PROPOSED SYSTEM

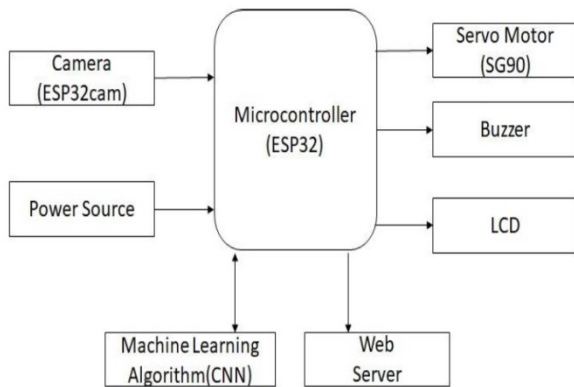

V. BLOCK DIAGRAM OF PROPOSED SYSTEM

HARDWARE COMPONENTS

The following hardware components are used in the proposed system

Power Supply, Node MCU ESP32, ESP32 Cam, Servo Motor, LCD, Buzzer

SOFTWARE COMPONENTS

The following software tools used in the proposed system

Arduino IDE, Proteus Design Tool, Web Server

VI. RESULT AND DISCUSSION

6.1 PROTOTYPE (THROUGH KIT)

shows the prototype of the project

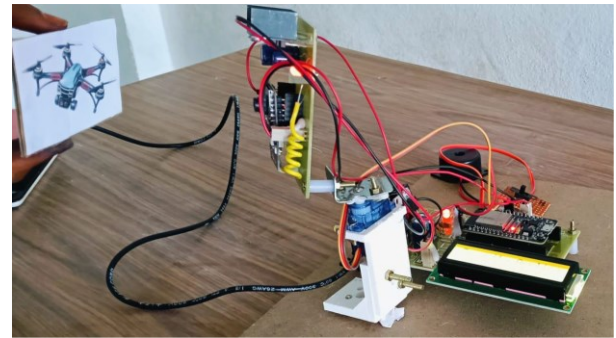
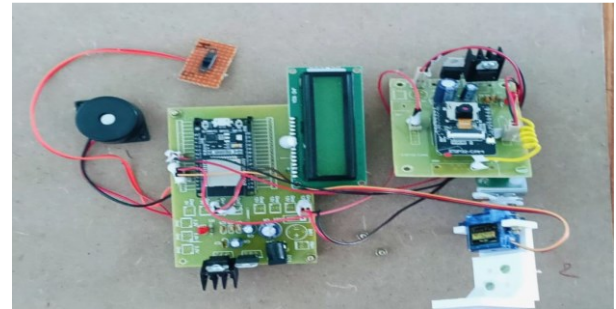

EXPERIMENTAL RESULTS

shows the real-time monitoring of the ESP32 camera

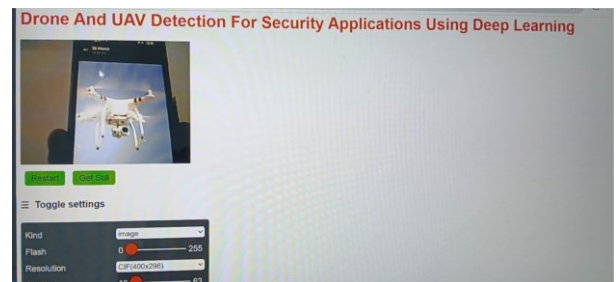

shows the data server page

S.No	Status	Date
1	Drone_UAV_Detected	2025-04-01 10:46:51
2	Drone_UAV_Detected	2025-04-01 10:46:44
3	Drone_UAV_Detected	2025-03-26 14:58:34
4	Drone_UAV_Detected	2025-03-26 14:58:28
5	Drone_UAV_Detected	2025-03-26 14:58:22
6	Drone_UAV_Detected	2025-03-26 14:58:16
7	Drone_UAV_Detected	2025-03-26 14:57:26
8	Drone_UAV_Detected	2025-03-26 14:57:14
9	Drone_UAV_Detected	2025-03-26 14:57:05
10	Drone_UAV_Detected	2025-03-26 14:56:57
11	Drone_UAV_Detected	2025-03-26 14:54:48
12	Drone_UAV_Detected	2025-03-26 14:54:30
13	Drone_UAV_Detected	2025-03-26 14:54:15
14	Drone_UAV_Detected	2025-03-26 14:53:34
15	Drone_UAV_Detected	2025-03-26 14:52:21
16	Drone_UAV_Detected	2025-03-26 14:52:03

VII. CONCLUSION AND FUTURE SCOPE

The UAV and drone detection system using machine learning marks a significant step forward in security and surveillance technologies. By combining IoT components like ESP32 and ESP32-CAM with advanced machine learning algorithms, the system demonstrates remarkable efficiency and accuracy in detecting and tracking drones. Its adaptability ensures it can be scaled for various applications, including airspace monitoring, wildlife tracking, and disaster management. The integration of servomotors for real-time tracking adds precision, while the use of Telegram bots and LCD displays ensures effective communication and control. As industries evolve, these systems will become pivotal in addressing safety challenges and monitoring critical areas. With future advancements, such as integration with 5G networks and improved AI models, their capabilities are set to expand. The system not only enhances security but also paves the way for innovative applications in multiple domains. Its modular design and real-time functionality make it a versatile and scalable solution. Overall, this technology embodies the future of automated detection and monitoring systems.

VIII. FUTURE SCOPE

The future scope of UAV and drone detection systems using machine learning is vast and promising. These systems can be enhanced for more precise and real-time monitoring by incorporating advanced algorithms and hardware. They hold immense potential in security applications like airspace management,

border surveillance, and critical infrastructure protection. Integration with 5G networks could enable faster data processing and improved connectivity. With advancements in AI, these systems could detect multiple drones simultaneously and even predict their trajectories.

REFERENCE

1. Convolutional Neural Network-Based Real-Time Object Detection and Tracking for Parrot AR Drone 2, ALI ROHAN, MOHAMMED RABAH, AND SUNG-HO KIM¹ School of Electronics and Information Engineering, Kunsan National University, South Korea, Department of Control and Robotics Engineering, Kunsan National University, Gunsan
2. Real-Time, Cloud-based Object Detection for Unmanned Aerial Vehicles Jangwon Lee, Jingya Wang, David Crandall, Selma Sabanovic, and Geoffrey Fox School of Informatics and Computing Indiana University
3. Using Shape Descriptors for UAV Detection, Eren Unlu, Emmanuel Zenou, Nicolas Riviere, Eren Unlu, Emmanuel Zenou, Nicolas Riviere. Using Shape Descriptors for UAV Detection. Electronic Imaging 2017, Jan 2018, Burlingame, United States. pp. 1-5.
4. Drone Detection and Identification System using Artificial Intelligence, Dongkyu 'Roy' Lee, Woong Gyu La and Hwangnam Kim, School of Electrical Engineering, Korea University, Seoul, Rep.

5. A Study on Detecting Drones Using Deep Convolutional Neural Networks, Muham-mad Saqib, Nabin Sharma, Sultan Daud Khan
6. J. Redmon, S. Divvala, R. Girshick, and A. Farhadi, "You only look once: Unified, real-time object detection," in Proc. IEEE Conf. Comput. Vis. Pattern Recognit. (CVPR), Jun. 2016, pp. 779-788.
7. R. Girshick. Fast r-cnn. In Proceedings of the IEEE International Conference on Computer Vision, 2015.
8. Support Vector Machines: Theory and Applications, Theodoros Evgeniou¹ and Massimiliano Pontil²
9. S. Ren, K. He, R. Girshick and J. Sun. Faster r-cnn: Towards real-time object detection with region proposal networks. In Advances in neural information processing systems, pages 91–99, 2015.
10. YOLO9000: Better, Faster, Stronger Joseph Redmon, Ali Farhadi, University of Washington, Allen Institute for AI