

**International Journal of
Engineering Research and Science & Technology**



ISSN : 2319-5991

www.ijerst.com

Email: editor@ijerst.com or editor.ijerst@gmail.com

Dual Active Bridge Converters A Comparative Analysis using MATLAB Simulink for Photovoltaic Applications

¹G. Subbarao Gupta,²Kondavaripalli Sravanthi,³Cv Nikhil,⁴Magatham Naresh Babu,

⁵Dudekula Mahammad Jakeer Hussain,

¹Senior Faculty, Department Of EEE, Ananthalakshmi Institute Of Technology And Sciences, Itikalapalli, Near Sk University, Ananthapur.

^{2,3,4,5}Student, Department Of EEE, Ananthalakshmi Institute Of Technology And Sciences, Itikalapalli, Near Sk University, Ananthapur.

Abstract

Using dual active bridge converters is one comprehensive way to connect the PV array to the load. Compared to other converters, DAB converters have better efficiency, a higher voltage-to-conversion ratio, and galvanic isolation. Dual Active Bridge converters are the focus of this article. The operation of the DAB converter is first examined using a DC source, after which the PV array is connected to the DAB, and the voltage and current are controlled using the Perturb & Observe MPPT algorithm. The AC motor is linked as a load to the inverter, which receives interface data from the PV array using the DAB converter. Using Simulink, we simulate the analysis of the different suggested models, as indicated before, and the findings are confirmed. Inverter, photovoltaic system, dual active bridge converter

INTRODUCTION

Using the principle of alternating current (AC) power transmission, Dual Active Bridge (DAB) converters are a kind of switch mode power supply. The word "active" comes from the fact that it is a bridge made with transistors, and "dual" means that there are two of them. DAB is composed of two bridges that can be controlled, and it transfers power between two locations by means of alternating current (AC) voltages and currents. In its most basic form, DAB is just a transformer connecting two bridges. Both the rectification procedure and the conversion from AC to DC take place in converters. Arguments in Favor of DAB: The voltage transmission ratio is wide. High power handling capabilities, isolation, zero voltage switching, bidirectional power transmission, and current feeding are all features of this circuit. DAB Microgrids, electric vehicles, on-board chargers, and

Photo voltaics are among of the uses for DAB. Two distinct varieties of dual active bridge converters are: A pair of active bridges instead of one • A dual-active bridge that is isolated As its name suggests, a non-isolated DAB converter does not include isolation. H A2 is not available in the Amrita School of Engineering, Amrita Vishwa Vidyapeetham, Bengaluru, India's Department of Electrical and Electronics Engineering. The two H-bridges are connected by an isolation transformer, according to ha_vidya@blr.amrita.edu2. It is possible to construct this topology with only two switches and one additional inductor, as stated in [1]. Using a high-frequency transformer, an isolated DAB converter may provide galvanic isolation between two H-bridges. A more adaptable conversion gain is achieved in this way. Because DC power is first converted to high frequency AC voltage and then rectified back into DC voltage, this design is somewhat more complicated in practice than standalone DAB converters.

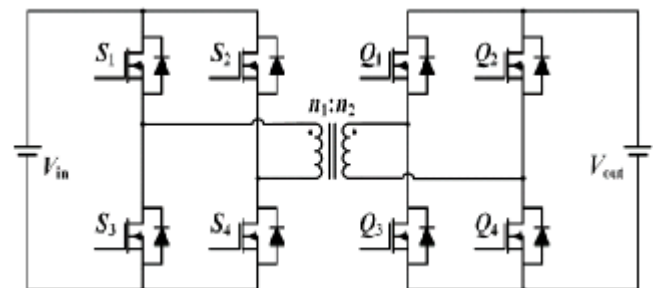

Fig.1. Isolated Dual Active Bridge Converter

Figure 1 depicts the universal structure of the isolated DAB converter. More efficiency, galvanic isolation,

bidirectional power flow, and buck-boost voltage functioning are all made possible by this circuit. Operation: Figure 1 shows a synchronous rectification circuit. At V_{out} , the bridge functions as a synchronous rectifier, transferring power from V_{in} to V_{out} . The bridge at V_{in} functions as a synchronous rectifier when power is transferred from V_{out} to V_{in} . An alternative topology to the one described before may be implemented by inserting a leakage inductance, denoted as L_k , after the first H Bridge but before the transformer. Its primary function is to transfer electrical current from the input to the output.

PHOTOVOLTAIC SYSTEM BASED DAB CONVERTER

Renewable energy sources are chosen according to the geographical zone. Depending on the incoming sun irradiation, using solar photovoltaics (PV) as an application or DC source is a practical option because of their widespread availability. Power conversion devices, such as buck and boost converters, are ideal for drawing electricity from photovoltaic systems; their operation is dependent on the load. The P&O technique, an MPPT tracking mechanism, is used as a control mechanism for the dual active bridge converter due to the variable irradiance levels in photovoltaics.

TABLE I. Modes of operation of DAB Converter

SL.No.	Mode of operation	Switches in ON position	Diodes in ON position
1	M1	S3	DQ2, DQ3
2	M2	S1, S4, Q2, Q3	--
3	M3	S1	D2, DQ1, DQ4
4	M4	S2, S3, S1, S4	--
5	M5	--	D1, D4, DQ2, DQ3
6	M6	S1, S4	DQ1, DQ4
7	M7	--	D2, D3, DQ1, DQ4
8	M8	S2, S3	DQ2, DQ3

Industrial applications may make advantage of these setups. The block diagram seen in Figure 2 may be rendered [2-3] for use in industrial applications.

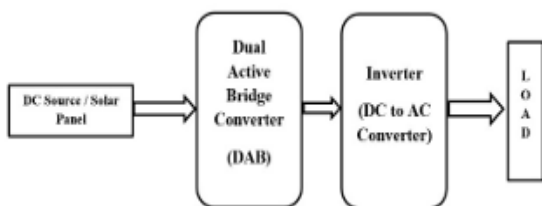

Fig.2. Block diagram of DAB used in industrial applications.

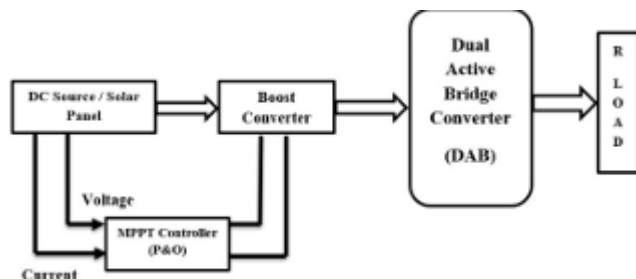

Fig.3. Block diagram of DAB with PV as the DC source implemented with MPPT controller.

Figure 3. One kind of bidirectional converter is the dual active bridge converter, which can switch between supplying power to the load and receiving it from the source. In order to increase the voltage, the DAB converter is linked to a boost converter in order, which supplies it with DC power. The dual active bridge converter is the last component that feeds the resistive load. The MPPT tracking mechanism, also known as the P&O technique, is used to both manage the boost converter's ability to produce an extreme power output from solar panels and to provide switching pulses to the MOSFETs inside the converter. A number of power converter topologies have been fine-tuned to maximize efficiency, voltage-to-conversion ratio yield, and load-voltage regulation. Use of MPPT monitoring technologies is fraught with complications. The following are examples of some of the issues: Reduced power is the result of MPPT being trapped in local MPP. • Developing sophisticated MPPTs for use in worldwide MPP Problems with overvoltage may arise with DMPPT.

A number of converter topologies exist, each with the potential to address the issues listed above. Because of this, the efficiency of a boost converter drops as the high voltage conversion ratio rises. When designing other types of boost converters, the number of inductors and capacitors used has a direct impact on the circuit's power density and efficiency. Therefore, the switching components are less stressed with an isolated converter. Dual active bridge converters provide for a greater scale voltage conversion ratio. With a voltage gain ratio of 1:N, the galvanic isolation in this circuit is provided by a high frequency transformer [4-7]. Combine two active bridge converters into one Determined by the capacity of the PV modules. Choose the suitable turns ratio, often known as the high frequency transformer 1:N. Following these procedures will ensure that the PV module's parameters are considered under STC circumstances. • The frequency at which switches are made ($F_s = 1/T_s$). A smaller transformer is required when F_s is greater than.

PHOTOVOLTAIC SYSTEM

Renewable energy resources throughout the world are seeing a surge in popularity, and solar power is at the forefront of this movement. In this study, the stand-alone grid system is analyzed. Delivering for ZVS requires a DAB converter with input/output isolation. The following are the details of the PV array that was used for the simulation:

TABLE II: Solar cell characteristics

SL.No.	Parameter	Ratings
1	Power at Max	213.15W
2	Voltage of cell at P_{max}	29V
3	Current of cell at P_{max}	7.35A
4	SCC (I_{sc})	7.84A
5	OCV (V_{oc})	36.3V
6	No. of series connection	12
7	No. of parallel connection	40

Luminance of the sun (W/m^2): The solar panel receives its input in increments of irradiance determined hourly. To test the DAB converter's responsiveness to changes in the solar irradiance input values to the PV array, the signal builder

provides 24 values that account for an hour's duration [8]. The hourly data is shown on the x-axis of Figure 4, while the irradiance value is shown on the y-axis in W/m^2 .

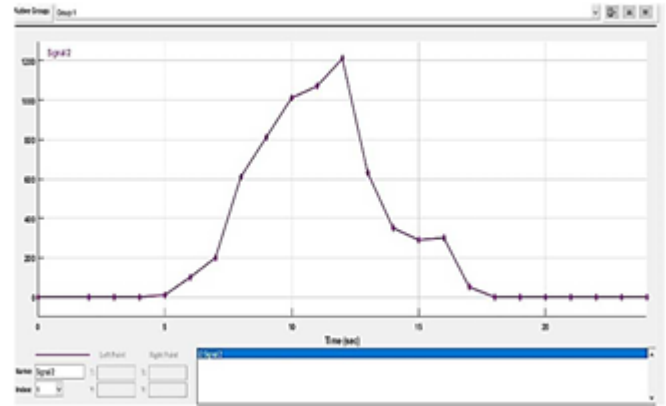

Fig.4. Different values of irradiance given as input to the solar array in MATLAB through signal builder

MPP Tracking Controller To maintain maximum power output regardless of temperature or irradiance fluctuations, a tracking system or charge controller may be necessary. To successfully simulate the functioning of a dual active bridge converter throughout its run time, this work takes into account the most basic way among the several MPPT methods used in diverse applications: the perturb and observe method [9–11]. Machine learning: Initial Step: Launch the Simulation The second step is to measure the voltage and current. In Step 3, verify that $P(k)-P(k-1)$ is equal to zero. If this is not the case, then check that $P(k)-P(k-1)$ is bigger than zero. In Step 4, we verify whether the difference between $P(k)$ and $P(k-1)$ is larger than 0. whether it is, we raise V_{ref} . Otherwise, we lower V_{ref} . Fifth Step: whether the difference between $P(k)$ and $P(k-1)$ is more than 0, then check whether the difference between $V(k)$ and $V(k-1)$ is larger than 0. If it is, then lower V_{ref} . If it is not, then raise V_{ref} . Sixth Step: Get Your Money Back from the C BOST Converter A boost converter is a kind of converter that increases the voltage output relative to the input voltage. Its simple design including a switch, inductor, and capacitor will assist in increasing the input voltage to an intended level.

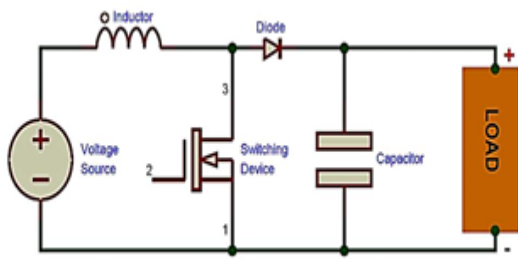

Fig.5. Boost converter circuit In the simulated MATLAB circuit boost converter operation is done using a MOSFET switch. The specifications is as follows:

ANALYSIS OF DUAL ACTIVE BRIDGE CONVERTER USING MATLAB SIMULINK

MATLAB SIMULATION OF DAB CONVERTER

The DAB converter model in MATLAB is shown in Figure 6. In this particular device, known as a DC to DC converter, the inverter moves from a DC supply to an AC one. The next step is to use a linear transformer to either raise or reduce the AC voltage. The rectifier then converts the AC current to DC. At the output side, a capacitor is used to filter out the direct current (DC) voltage.

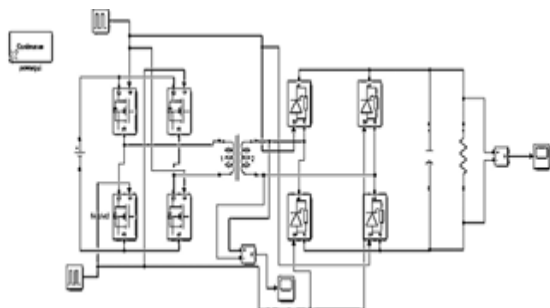

Fig.6. MATLAB Circuit of DAB converter Linear Transformer:

1000W is the nominal power and 2000 Hz is the nominal frequency. 10V is the input DC voltage. 100V is the step-up voltage. {{The load resistance is 1000.}} A 1000μF output capacitor. The simulation ran at an output voltage of 95V.

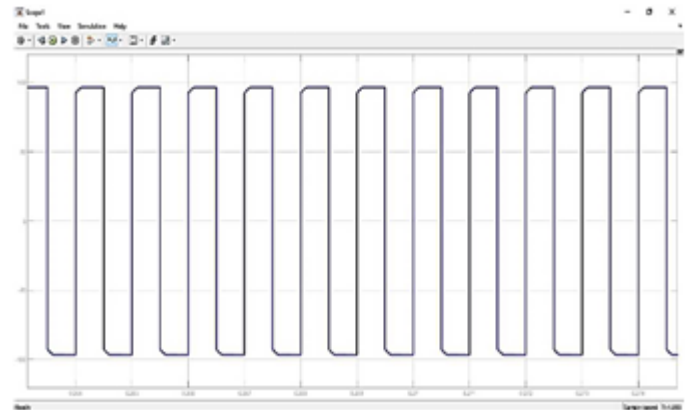

Fig.7. Linear transformer output



Fig.8. Output voltage of DAB converter is around 95volts

B. MATLAB SIMULATION OF DAB CONVERTER WITH PV ARRAY INPUT

Figure 9 shows the results of a MATLAB model of a DAB converter using a photovoltaic array as its direct current source. A user-defined solar array with 40 strings connected in series and parallel was chosen.

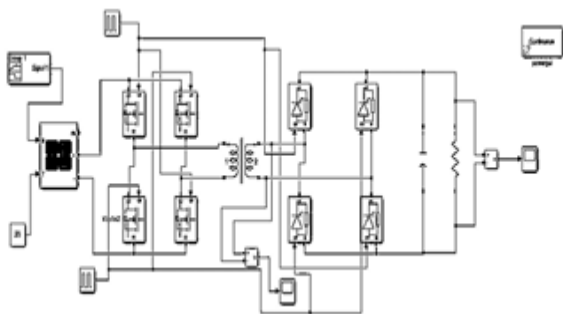

The output of the linear transformer and DAB converter are shown below with an input irradiance of 1000w/m2 and a temperature of 25°C.

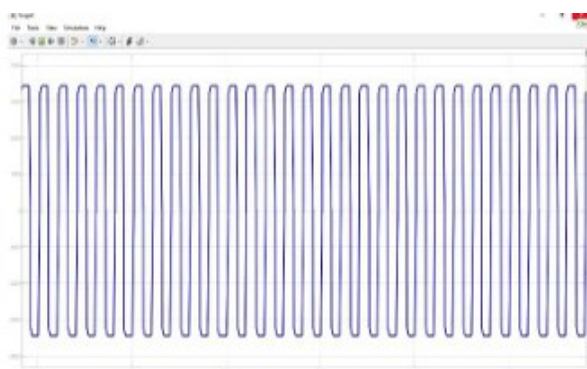

Fig.10. Output of linear transformer with PV array as input DC source

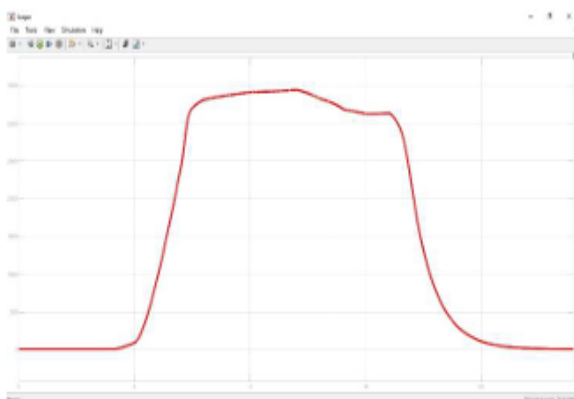

Fig.11. DC output voltage is around 3500V

MATLAB SIMULATION OF DAB CONVERTER WITH PV ARRAY INPUT (VARIABLE IRRADIANCE VALUES)

The DAB converter's analysis is confirmed for varying irradiances using data provided over a 24-hour period. The input data for each hour is represented by an irradiance value of w/m2 [12–15]. Figure 12 shows the circuit used in the MATLAB simulation.

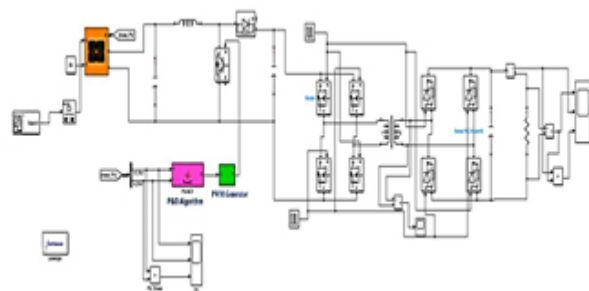

fig.12. MATLAB simulation of DAB converter with PV array input (variable irradiance)

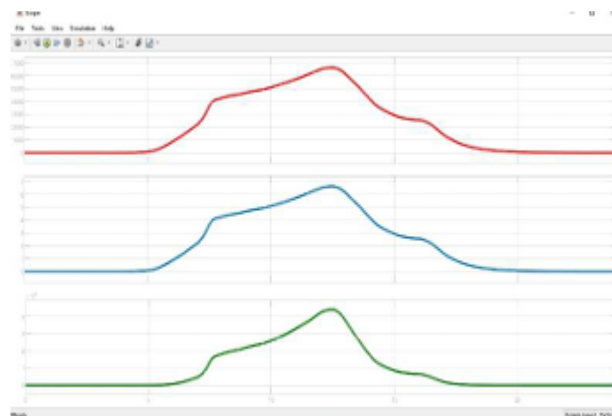

Fig.14. Output of DAB converter in terms of voltage, current and power TABLE III: Sample values of load output drawn from variable irradiance values of PV array input

SL.No.	Load Voltage (V)	Load Current (A)	Load Power (KW)
1	4.073k	4.073	16.59k
2	5.677k	5.677	32.22k
3	6.65k	6.65	44.23k
4	2.978k	2.978	8.87k
5	0.858k	0.8585	0.7369k

MATLAB SIMULATION OF DAB CONVERTER WITH AND INVERTER AND INDUCTION MOTOR

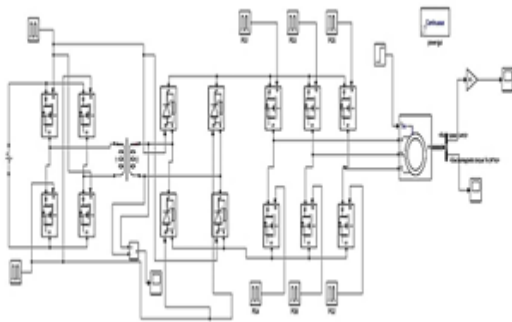
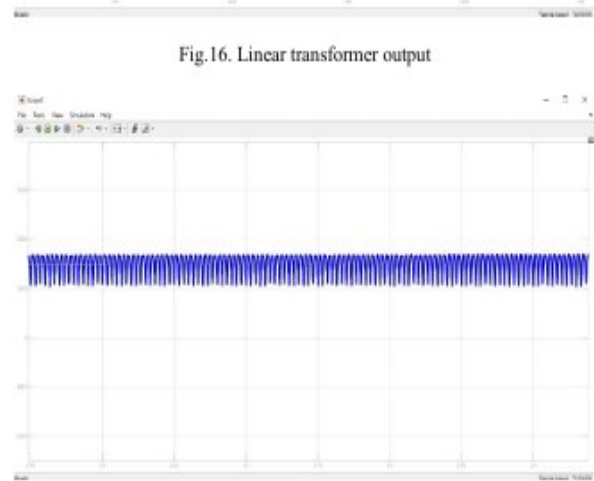
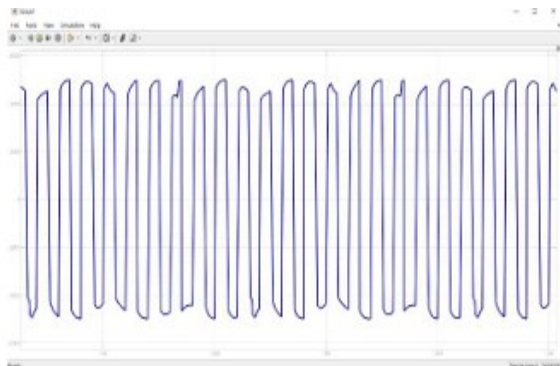

Fig.15. MATLAB Circuit of DAB converter connected to squirrel cage induction motor Motor specifications are 5HP, 460V, 1750RPM.



CONCLUSION

This work uses MATLAB Simulink to compare and contrast different circuits, with a focus on the dual active bridge converter. At first, we use Simulink to model a basic DAB converter. We start by simulating a basic DAB converter, where the input DC voltage is 10V and the output is raised to around 95V. The PV array is used as an input DC source to power the dual active bridge converters, and the waveforms are studied under different situations of constant and variable irradiance. The last part of the simulation involves feeding DAB into an inverter, which changes the DC voltage to AC. Then, the squirrel cage induction motor is fed this AC voltage, and the results are evaluated. This case study research analyzed the operation of dual active bridge converters under different operating situations, and the total simulation supplied insight into that operation.

REFERENCES

[1]. Ganesh chilakalapudi, Saikat Das, Amrithesh Kumar , Phanindra A V V N , “Photovoltaic and Battery sourced Multiport Converter fed Dual Active Bridge DC/DC converter with Multimode operation for Off grid Electric Vehicle Charging Application”, Research square, DOI: <https://doi.org/10.21203/rs.3.rs-3227979/v1>, August 14th, 2023.

[2]. Sinan Zengin, “A hybrid current modulated DAB DC/DC converter for connecting PV modules to DC grid considering partial shading”, Elsevier,

- <https://doi.org/10.1016/j.compeleceng.2022.108109>, 19 May 2022.
- [3]. Haris Ataullah , Taosif Iqbal, Ihsan Ullah Khalil , Usman Ali , Vojtech Blazek , Lukas Prokop and Nasim Ullah, “Analysis of the Dual Active Bridge-Based DC-DC Converter Topologies, High-Frequency Transformer, and Control Techniques”, *Energies* 2022, 15, 8944. <https://doi.org/10.3390/en15238944>, 26 November 2022.
- [4]. Diego Alejandro Herrera-Jaramillo, Elkin Edilberto Henao-Bravo, Daniel González Montoya, Carlos Andrés Ramos-Paja and Andrés Julián Saavedra-Montes , “Systematic analysis of control techniques for the dual active bridge converter in photovoltaic applications”, *International Journal of Circuit Theory and Applications* · April 2021.
- [5]. Shao, Shuai; Chen, Linglin; Shan, Zhenyu ; Gao, Fei; Chen, Hui; Sha, Deshang ; Dragicevic, Tomislav, “Modeling and Advanced Control of Dual Active Bridge DC-DC Converters”, *IEEE Transactions on Power Electronics*, 10.1109/TPEL.2021.3108157, 2021.
- [6]. James Arredondo, Marco Quispe and Midwar Valencia, “Particle Swarm Optimization MPPT algorithm in a Dual Active Bridge Series Resonant DC-DC Converter for Partial Shading Conditions”, *CCAC IEEE 5th Colombian Conference on Automatic Control (CCAC) October 19-22, 2021. Ibagué, Colombia*.
- [7]. K. Suresh, C. Bharatiraja, N. Chellammal, Mohd Tariq, Ripon K. Chakraborty, Michael J. Ryan, and Basem Alamri. “A multifunctional non-isolated dual input-dual output converter for electric vehicle applications”, *IEEE Access*, 9:64445–64460, 2021.
- [8]. Elkin Edilberto Henao-Bravo, Carlos Andrés Ramos-Paja, Andrés Julián Saavedra-Montes, Daniel González-Montoya and Julián Sierra Pérez, “Design Method of Dual Active Bridge Converters for Photovoltaic Systems with High Voltage Gain”, *Energies* 2020, 13, 1711; doi:10.3390/en13071711.
- [9]. Osama M. Hebala, Ahmed A. Aboushady, Senior Member, Khaled H. Ahmed, Senior Member, Ibrahim Abdelsalam, Samuel J. Burgess “New Active Power Controller in Dual Active Bridge DC-DC Converter with a Minimum-Current-Point-Tracking Technique”, *IEEE journal of emerging and selected topics in power electronics*, July 22, 2020.
- [10]. Nie Hou and Yun Wei Li. Overview and comparison of modulation and control strategies for a nonresonant single-phase dual-active bridge dc-dc converter. *IEEE Transactions on Power Electronics*, 35(3):3148–3172, 2020.
- [11]. Seedarala Likhith, Setlem Bhargavi, P.V Manitha, S Lekshmi, Amrita vishwa Vidyapeetham , “DC-DC Converter for EV Charger with Controlling Unit”, 2022 International Conference for Advancement in Technology (ICONAT), DOI: 10.1109/ICONAT53423.2022.9726034.
- [12]. B. Tejesh, B. S. Ganesh Charan, Ch. Murali Krishna, Manitha P. V, Amrita vishwa Vidyapeetham, “Development of Hybrid PV Wind system for EVs with Battery Management System”, 2022 Second International Conference on Advances in Electrical, Computing, Communication and Sustainable Technologies (ICAECT), DOI: 10.1109/ICAECT54875.2022.9808062.
- [13]. Sagar Navinchandran, Mini Sujith, Amrita vishwa Vidyapeetham, “Bidirectional On-Board Single Phase Electric Vehicle Charger with High Gain Boost Converter for V2G Application”, 2020 Fourth International Conference on Inventive Systems and Control (ICISC), DOI: 10.1109/ICISC47916.2020.9171133.
- [14]. Dr. J Ramprabhakar, Dr. S Syama, Amrita vishwa Vidyapeetham, " Multistep Ahead Solar Irradiance and Wind Speed Forecasting using Bayesian Optimized Long Short Term Memory," 2022 7th International Conference on Communication and Electronics Systems (ICCES), DOI: 10.1109/ICCES54183.2022.9835840.
- [15]. K. Poojitha, Ashwini, L., Anjali, B. S., and Dr. J. Ramprabhakar, Amrita vishwa Vidyapeetham, “Solar tracker using Maximum Power Point Tracking algorithm”, 2019 International Conference on Intelligent Computing and Control Systems (ICCS). IEEE, Madurai, India