



**International Journal of
Engineering Research and Science & Technology**



ISSN : 2319-5991

www.ijerst.com

Email: editor@ijerst.com or editor.ijerst@gmail.com

Hilly Area Accident Prevention System Based on Infrared Sensors

¹M. Saila Bhanu,²Dulam Umesh Chandra,³Akula Venkata Satya Manikanta Suryam,
⁴Bathina Gowtham Venkat,

¹Assistant Professor, Department of ECE, Rajamahendri Institute of Engineering & Technology.

^{2,3,4}Student, Department of ECE, Rajamahendri Institute of Engineering & Technology.

ABSTRACT:

Poor vision, steep inclines, and unexpected driving conditions greatly increase the risk of accidents on mountainous routes and sharp turns. Accidents involving head-on collisions are common because drivers don't always look both ways. An innovative accident prevention system including PIR and IR sensors, GPS, LED indications, and a buzzer alarm mechanism is proposed in this research to tackle this problem. To avoid accidents caused by unforeseen barriers, infrared sensors detect when a vehicle is in a blind area and passive infrared sensors detect when animals or humans are in close proximity to roadways. In the event of an accident, GPS can monitor the exact whereabouts of a car and relay that information in real time to rescue workers. When drivers are getting too close to potentially hazardous bends, a buzzer will sound an audible warning and LED indicators will show them the way. By facilitating proactive notifications, rapid emergency response, and real-time detection, this technology enhances road safety and, in the end, reduces accidents in dangerous mountainous terrains.

EMBEDDED SYSTEMS

A computer system that is purpose-built to carry out a single or limited set of tasks, often under the restrictions of real-time computing, is known as an embedded system. As with other physical and mechanical components, it is often integrated into a whole device. A personal computer or other general-purpose computer, on the other hand, may be programmed to do a wide variety of functions. These days, many of the everyday items we use rely on embedded systems to function. Design engineers may improve the embedded system to decrease product size and cost while boosting reliability and performance since it is devoted to certain functions. Because of their mass production, certain embedded systems are able to take advantage of cost savings. From small, handheld gadgets like digital watches and MP3 players to massive, permanently installed systems like those managing nuclear power plants, traffic lights, and industrial controls are all examples of physically embedded systems. From

simple systems using a single microcontroller chip to complex systems housing several modules, peripherals, and networks in a massive chassis or enclosure, complexity may range greatly. The phrase "embedded system" lacks a precise definition because the majority of systems have programmability in some form. While they share some components with embedded systems, such operating systems and microprocessors, handheld computers are not technically embedded systems as they enable the loading of multiple programs and the connection of peripherals. Computer hardware and software, either fixed in capability or programmable, particularly intended for a certain sort of application device—this is what's called an embedded system. Embedded systems may be found in a wide variety of objects, including but not limited to: vehicles, medical devices, cameras, home appliances, aircraft, vending machines, toys, and, of course, cellular phones and personal digital assistants. A programming interface is given to programmable embedded devices, and programming for embedded systems is a niche field in and of itself. Embedded Java and Windows XP Embedded are two examples of embedded-specific operating systems and language platforms. On the other hand, certain budget consumer goods include integrated application and operating system components, employ very cheap microprocessors, and have limited storage space. Instead of being loaded into RAM (random access memory), as applications on personal computers are, in this situation the program is written permanently into the system's memory.

CHARACTERISTIC OF EMBEDDED SYSTEM

- Speed (bytes/sec): Should be high speed
- Power (watts): Low power dissipation
- Size and weight: As far as possible small in size and low weight
- Accuracy (%error): Must be very accurate
- Adaptability: High adaptability and accessibility
- Reliability: Must be reliable over a long period of time

APPLICATIONS OF EMBEDDED SYSTEMS

Here, in the Embedded World, we are living. The smooth operation of the various embedded goods that surround you is crucial to your day-to-day existence. In your living room, you have a TV, radio, and CD player; in your kitchen, you have a washing machine or microwave oven; and at your office, you have card readers, access controllers, and palm devices that let you do a lot. In addition to all of this, your automobile has a plethora of built-in controls that handle functions between the bumpers, most of which you probably don't give a second thought to.

- **Robotics:** industrial robots, machine tools, Robocop soccer robots
- **Automotive:** cars, trucks, trains
- **Aviation:** airplanes, helicopters
- **Home and Building Automation**
- **Aerospace:** rockets, satellites
- **Energy systems:** windmills, nuclear plants
- **Medical systems:** prostheses, revalidation machine.

MICROCONTROLLER VERSUS MICROPROCESSOR

When comparing microprocessors and microcontrollers, what are the key differences? Any general-purpose microprocessor, such as an 8086, 80286, 80386, 80486, or a Pentium from Intel, or a 680X0 from Motorola, etc., is considered a microprocessor. In addition to lacking on-chip I/O ports, these microprocessors also lack random-access memory (RAM). Because of this, they are often called general-purpose microprocessors. Designing a working system around a general-purpose CPU like the 68040 or Pentium requires the addition of extra components like as RAM, ROM, I/O ports, and timers. Though these systems are more costly and cumbersome due to the inclusion of external RAM, ROM, and I/O ports, they provide the benefit of being versatile in that the designer may choose the quantity of RAM, ROM, and I/O ports required for the work at hand. Microcontrollers are an exception to this rule. On a single chip, you'll find a microprocessor, random access memory (RAM), read/write (ROM), input/output (I/O) ports, and a timer in a microcontroller. So, since the CPU, random access memory (RAM), read/write memory (ROM), input/output (I/O) ports, and timer are all integrated

into a single chip, the designer is unable to include any more memory, I/O ports, or timer into the product. Because of its set quantity of on-chip ROM, RAM, and number of I/O ports, microcontrollers are perfect for many applications where space and cost are important considerations. It is not necessary to have a 486 or even an 8086 CPU for many applications; for instance, a TV remote control. Typically, these programs will need some kind of input/output function in order to read signals and toggle bits.

INTRODUCTION

The population is growing at a faster pace now that we are in the 21st century. There is a greater potential for events to occur as the population grows. Today, there is a great deal of focus on preventing these gathering catastrophes. Being reckless, talking about security measures, etc., is the main cause of all these accidents [1]. Security gauges are also still to be changed, and accidents are happening, as technology is progressing at a more noticeable pace. Accidents were still occurring at a greater rate despite previous efforts to prevent them [2]. Poorly planned street bends, lack of guide rails, narrow shoulders, blind bends, slope peaks, poor permeability at intersections on slopes or bends, impaired permeability, and unlucky walkways are all examples of the flawed planning and development that can lead to accidents in hilly areas [3]. The suggested model is a warning system that shows potential accidents so that we may take basic precautions to avoid them. Consequently, this is a step in the direction of saving lives. In this paper, the author presents the model in nine sections: an introduction, a description of the system blueprint and its physical appearance (section 2), an inventory of the components and elements used in the model (section 3), an explanation of the model's methodology and execution process (section 4), a view of the working procedure and flowchart diagrams (section 5), and finally, experimental results accompanied by figures (section 6). Finally, this work has reached its end with section

LITERATURE SURVEY

In order to get around this problem with the present framework, we created a new one that doesn't use ultrasonic sensors for testing accidents. These sensors are installed on both sides of the road. This system makes use of all four sensors. Each side of the road has two sensors: two on the left and two on the right. It makes use of two lights or signals. The signal will ring loudly and lights will dazzle. Infrared sensors are used to identify the vehicle and

a signal is sent by a light so that an accident may be prevented. People are able to determine the exact location of the car at the intersection using this method. Executing this procedure is a breeze. Keep yourself and others safe from harm [4]. The whole model view of the Arduino Uno microcontroller is shown in figure 1. Our strategy includes a power source. This transfer uses a tiny voltage loop to manage the car engine's condition, slow down the engine and the bell, and maintain a resultant voltage that is the steady value of five volts predicted by the microcontroller. If the driver is being too sluggish, a bell will sound and a warning notice will be shown to alert them. Drivers of nearby vehicles may use a preprogrammed slowing mechanism to bring their vehicles to a gradual stop [5].

EXISTING SYSTEM

Static road signs, convex mirrors, and human traffic control are the traditional tools used to alert drivers of oncoming cars in steep areas. Even while these solutions provide a certain amount of protection, they won't work when driving in very bad weather like fog, severe rain, or at night. There is a delay in reaction time in accident-prone locations since current systems do not include automatic vehicle detection, real-time position monitoring, or fast alarm methods. Because there is currently no way for emergency services to communicate and identify accidents using GPS, reaction times are notoriously sluggish. The lack of specialized devices to monitor the presence of people or animals near roadways further increases the likelihood of accidents caused by unexpected impediments. Consequently, to improve real-time accident response and prevention, an integrated system is required that uses several sensor technologies.

PROPOSED MODEL

To provide a thorough safety solution, the suggested accident prevention system integrates PIR and IR sensors with GPS tracking, LED indications, and a buzzer system. When cars are detected by infrared sensors approaching blind bends, warning lights and a buzzer go off to let other drivers know. By identifying the presence of people and animals in close proximity to roadways, PIR sensors improve safety and eliminate potential hazards. To facilitate quicker emergency response in the event of an accident, the GPS module monitors the vehicle's movements and sends out real-time position data. A microcontroller based on Arduino handles all of the system's sensor inputs and sends out notifications as needed. A dependable option for lowering the number of

traffic accidents in mountainous terrain, this system is inexpensive, simple to implement, and very efficient.

BLOCK DIAGRAM

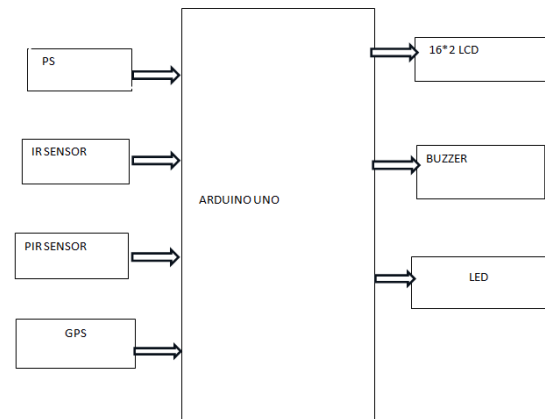

Figure 1: Block Diagram

Microcontroller:

A tiny controller, or microcontroller, as the name implies. Often used as a processing or controlling unit, they are similar to single-chip computers. For instance, microcontrollers that do decoding and other regulating operations are likely integrated into the control you are using. They find further use in vehicles, home appliances, microwaves, toys, and any other area requiring automation.

Arduino Uno Microcontroller:

One such microcontroller board is the Arduino Uno, which uses the Atmega328 (datasheet). It has a 16 MHz crystal oscillator, 6 analogue inputs, 14 digital input/output pins (6 of which may be used as PWM outputs), a power connector, an ICSP header, a reset button, and a USB connection. All you need is a USB cable, an AC-to-DC converter, or a battery to get it going; it comes with everything you need to support the microcontroller.

A key difference between the Uno and all previous boards is the absence of the FTDI USB-to-serial driver chip. Rather of that, it has an Atmega8U2 that has been configured to convert USB to serial. To celebrate the impending release of Arduino 1.0, the name "Uno"—which means "One" in Italian—has been chosen. The Uno and Arduino version 1.0 will serve as the foundational versions for future Arduino releases. For a comparison with prior generations, see the index of Arduino boards. The Uno is the newest in a series of USB Arduino boards and the standard model for the Arduino platform.

ARDUINO UNO BOARD:

One board that uses the Atmega328 microprocessor is the Arduino Uno. A 16 MHz ceramic resonator, 6 analog inputs, 14 digital I/O pins (including 6 PWM outputs), 1 USB port, 1 power connector, 1 ICSP header, and 1 reset button are all part of it. All you need is a USB cable, an AC-to-DC converter, or a battery to get it going; it comes with everything you need to support the microcontroller.

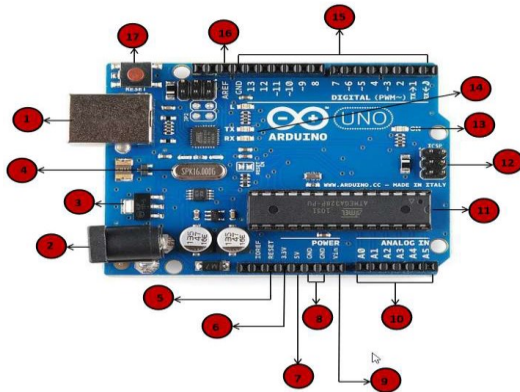

Figure 2: Arduino uno board

In contrast to all of its predecessors, the Uno does not have the FTDI USB-to-serial driver chip. As an alternative, it makes use of USB-to-serial converters coded into the Atmega16U2 (Atmega8U2 up to version R2).

HARDWARE COMPONENTS

POWER SUPPLY UNIT

The power supply for this system is shown below.

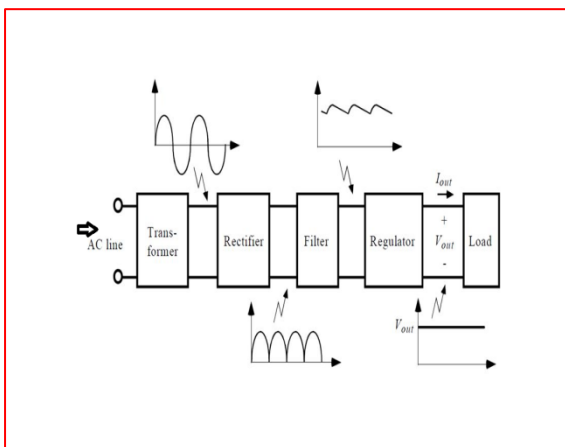

Figure 3: power supply

Diodes:

Only one path of electrical current may pass through a diode. Current may flow in either direction, as shown by the arrow in the circuit symbol. Originally termed valves, diodes are essentially an electrically enhanced version of the mechanical component.

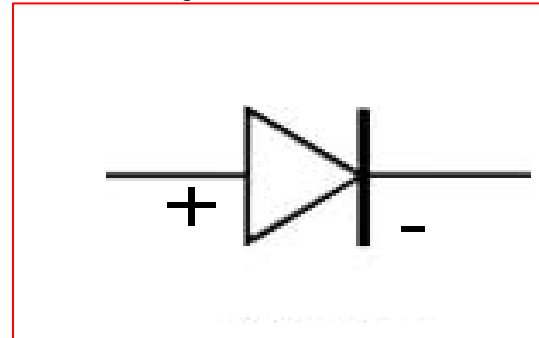

Figure 4: Diode Symbol

One kind of electrical component that restricts current flow is the diode. A voltage loss of around 0.7V will be the sole influence on the signal when the diode is "forward-biased" in this way. No current will flow through a diode that is "reverse-biased" when the current is applied in the other direction.

Rectifier

A rectifier's job is to change the phase of an alternating current (AC) waveform so that it appears as a direct current (DC) waveform. Both "half-wave" and "full-wave" rectifiers are used for rectification. Diodes are used in both devices to convert AC current into DC current. The Half-Wave Rectifiable The graphic shows that the half-wave rectifier is the simplest rectifier type since it only employs one diode.

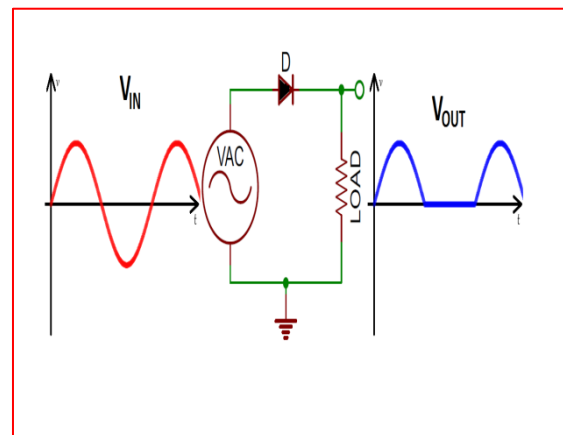

Figure 5: Half Wave Rectifier

LIQUID CRYSTAL DISPLAY

An array of color or monochrome pixels arranged in front of a light source or reflector makes up a liquid crystal display (LCD), a thin, flat display device. Two polarizing filters, with their polarity axes perpendicular to one other, and a column of liquid crystal molecules hanging between two transparent electrodes make up each pixel. Light would not be able to travel through them if the liquid crystals weren't interposed. To make light flow through two filters, the liquid crystal changes the polarization of the light entering the first filter.

A program's ability to communicate with the outside world depends on its input and output devices, which in turn rely on human communication. An LCD display is a typical accessory for controllers. 16X1, 16x2, and 20x2 LCDs are among the most popular types of displays that are often linked to the controllers. Which works out to sixteen characters on a single line. The first set has 16 characters on each line while the second set has 20 characters on each line. The use of "smart LCD" displays allows for the visual output of information by many microcontroller devices. Affordable, user-friendly, and capable of producing a readout utilizing the display's 5X7 dots plus cursor, LCD displays built on the LCD NT-C1611 module are a great choice. They use mathematical symbols and the usual ASCII set of characters. The display needs a +5V power and 10 I/O lines (RS, RW, D7, D6, D5, D4, D3, D2, D1, D0) for an 8-bit data bus. The only additional lines needed for a 4-bit data bus are the supply lines and six more (RS, RW, D7, D6, D5, D4). The data lines are tri-state and do not affect the microcontroller's function when the LCD display is disabled.

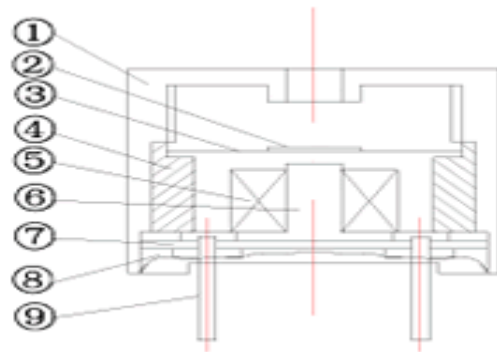

Figure 6: 2x16 LCD Display

BUZZER

In a magnetic transducer, the circuitry includes an iron core, a yoke plate, a wound coil, a permanent magnet, and a vibrating diaphragm that can be moved. The magnet's field gently draws the diaphragm up nearer the core's surface. A positive alternating current (AC) signal causes the

diaphragm to move up and down, which in turn vibrates the air. This is achieved by the current passing through the excitation coil, which forms a fluctuating magnetic field. A resonator, which is composed of a cavity and one or more sound holes, may amplify vibrations in order to generate a loud sound.



ESP8266 Wi-Fi Module

This project revolves on this. Because the project relies on WIFI control of appliances, the module is a crucial part of it. One remarkable feature of this tiny board is the integrated MCU (Micro Controller Unit), which allows for the control of I/O digital pins via a simple programming language that is almost pseudo-code like. Another benefit is that the ESP8266 Arduino compatible module is a low-cost Wi-Fi chip with full TCP/IP capability. The Chinese company Es press if Systems is situated in Shanghai and makes this gadget. In August 2014, this chip made its debut in the ESP-01 version module manufactured by the third-party company AIThinker. The MCU can establish basic TCP/IP connections and connect to WiFi networks with the help of this little module. He was His tiny size and cheap pricing (1.7–3.5\$) enticed a lot of hackers and geeks to look into it and utilize it for all sorts of projects. Because of its enormous success, Espressif now offers a wide variety of models with varying size and technological specs. Its replacement includes ESP32.

RELAYS:

Industrial controls, automotive systems, and home appliances all make extensive use of electrically controlled switches called relays. By using a relay, two independent voltage sources may be isolated from one another; in other words, a little quantity of voltage or current on one side can manage a big amount of current or voltage on the other side, and vice versa.

Inductor

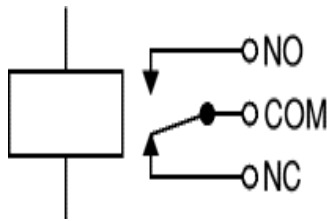

Fig7 : Circuit symbol of a relay

DRIVING A RELAY:

Two of the SPDT relay's five pins are used by the magnetic coil, one serves as the common terminal, and the other two are typically closed and normally connected. The coil is activated when a current passes across it. At the beginning, when the coil is deenergized, the usually closed pin and common terminal will be connected. A new connection will be formed between the common terminal and usually open pin when the coil is activated, breaking this connection. Therefore, the relay will be activated whenever the microcontroller sends an input signal to it. You may drive the loads connected between the common terminal and typically open pin while the relay is on. Consequently, the high-current loads are driven by the relay, which receives 5V from the microcontroller. This means the relay may be used as a means of isolation. The microcontroller and digital systems do not have enough current to operate the relay. In contrast to the 10 milliamps required to activate the relay's coil, the microcontroller's pin can only provide 1 or 2 milliamps. This is why the microcontroller and the relay are separated by a driver, like ULN2003, or a power transistor. By connecting ULN2003 to the relay and microcontroller, it is possible to activate many relays simultaneously.

SOFTWARES

The Arduino platform is an open-source, user-friendly hardware and software environment for prototyping. It is comprised of a programmable circuit board (also called a microcontroller) and an Integrated Development Environment (IDE) called Arduino that is pre-made for writing and uploading code to the physical board. The main characteristics are:

- Many sensors can send signals in digital or analog formats to Arduino boards, which may then be used to activate motors, control LEDs, establish connections to the cloud, and much more.
- The Arduino IDE (also called "uploading software") allows you to command your board's

operations by communicating with the microcontroller on the board.

- A separate device, known as a programmer, is not required to load fresh code into an Arduino board, in contrast to most prior programmable circuit boards. The usage of a USB connection is all that is required.
 - The Arduino IDE employs a streamlined version of C++, which facilitates programming learning. Last but not least, Arduino offers a standardized form factor that simplifies the microcontroller's tasks.
- Now that we know what the Arduino UNO board is and how it works, we can go on to setting up the Arduino IDE. As soon as we figure this out, we can upload our software to the Arduino board.

RESULTS

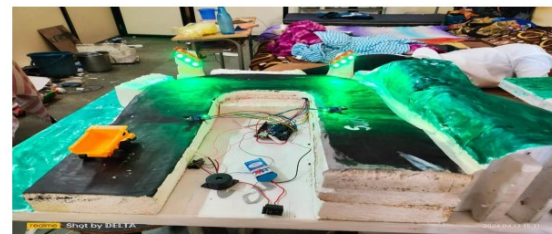

Output

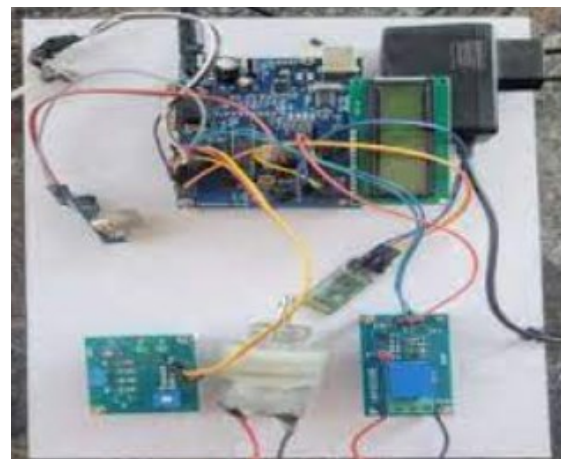

Model

CONCLUSION

An new and practical method to improving road safety in steep terrains is offered by the suggested accident prevention system, which integrates PIR sensors, IR sensors, GPS, LED indicators, and a buzzer system. This technology provides drivers with immediate notifications, obstacle awareness, and real-time vehicle recognition, unlike conventional safety measures. The inclusion of

GPS technology allows for the instant notification of emergency services and the tracking of accident sites. The use of both visual and aural warnings increases driver awareness, which in turn decreases the likelihood of accidents and collisions. Automated braking systems, Internet of Things connection for cloud-based data processing, and artificial intelligence predictive analytics for accident avoidance are all potential future upgrades. By using this approach, the number of accidents in mountainous locations may be drastically reduced, resulting in safer roads for all drivers.

REFERENCES

[1] SmDwaipayan Saha^{1*}, Indrani Mukherjee², Jesmin Roy³, Sumanta Chatterjee⁴, “Smart Safety and Accident Prevention System for Mountain Roads” International Journal of Computer Sciences and Engineering Research Paper Vol.-8, Special Issue-1, pp. 16-18 (Feb 2020).

[2] Deepthi Jha, Harshit Sharma, Priyanshu, “Smart Road Safety and Automatic Vehicle Accident Prevention System for Mountain Roads” International Journal of Engineering and Technical Research (IJETR) ISSN: 2321-0869 (O) 2454-4698 (P), Volume 10, Issue 6, pp. 17-19 (June 2020).

[3] Aravinda B1, Chaithralakshmi C1, Deeksha1, Ashutha K2, “Sensor Based Accident Prevention System” INTERNATIONAL JOURNAL OF INNOVATIVE RESEARCH IN ELECTRICAL, ELECTRONICS, INSTRUMENTATION AND CONTROL ENGINEERING(IJIREEICE) Vol. 4, Issue 6, pp. 14-17 (June 2016).

[4] Shubham Verma¹, Umesh Kumar Singh², Vivek Kumar³, Aakansha Singh⁴, “SMART ROAD SAFETY AND VEHICLE ACCIDENT PREVENTION SYSTEM FOR MOUNTAIN ROAD” National Conference on Industry 4.0(NCI-4.0), Pp. 134-140(2020).

[5] Mrs. Y. Lavanya, M. Monika Rani, M. Sai Swaroop, P. Raja, Y. Rajesh, Dr. L. Bharathi, “Smart Road Safety and Vehicle Accident Prevention System for Mountain Roads” JAC : A Journal Of Composition Theory Volume XIV, Issue VIII, pp. 201-207 (AUGUST 2021).