

**International Journal of
Engineering Research and Science & Technology**



ISSN : 2319-5991

www.ijerst.com

Email: editor@ijerst.com or editor.ijerst@gmail.com

Implementing a CNN and Raspberry Pi system to safeguard crops against animal threats

¹ S.Prashanth, ² Bompally Sai Nithya Goud, ³ Mohammed Waseem Khan, ⁴ Kandula Naveen Kumar, ⁵ Dr.V.Purandar Reddy,

^{1,2,3,4} Student Department of ECE, Narsimha Reddy Engineering College, Maisammaguda (V), Kompally, Secunderabad, Telangana-500100.

⁵ Associate Professor, Department of ECE, Narsimha Reddy Engineering College, Maisammaguda (V), Kompally, Secunderabad, Telangana-500100.

ABSTRACT

With the use of publicly accessible hardware and firmware, we developed a prototype of an automated smart field monitoring and protection system to help farmers prevent several factors that usually lead to a decrease in crop output. It is usually difficult to keep an eye on the weather and environmental conditions around the clock. To overcome this, we have devised a crop field project that uses the internet of things (IoT), an Arduino, and sensors that measure important parameters throughout the day, such as temperature, moisture, and humidity. One further usage of IoT is the transmission of sensor-measured parameters. With the help of the criteria that have been identified, we may spray pesticides to detect and stop agricultural yield loss.

INTRODUCTION

Local wildlife, including buffalo, goats, elephants, and birds, often preys on agricultural crops. As a result, the farmer suffers significant losses. The overpopulation of human settlements causes deforestation because it reduces the availability of food, water, and shelter in forested regions. Consequently, animal engagement in residential settings is on the rise, endangering human health and property and leading to conflicts between the two. But the rules of nature state that every single living creature on Earth contributes significantly to the overall health of the ecosystem. When elephants and other animals interact with people, it may lead to a cascade of negative consequences, such as crop failure, contamination of water sources, damage to houses and other structures, and even death. To a large extent, agriculture drives India's economy. Agribusiness has a crucial role in addressing human issues due to the exponential growth of the global population. The development of farmers and the country's economy are both greatly impacted by it. It also creates a great deal of work openings for people in general. A safety system to guard the farm and keep animals out may

be built with the help of the Automated Smart Agricultural Protection System. An Internet of Things (IoT) module notifies the farmer. Protecting plants from animals is another benefit. No human presence or random movement in the arena will set off the alert, thanks to the mechanism. Stadiums are safeguarded by the device's ability to autonomously switch on and off and escape predators. Additionally, we may adjust the timing to suit the farmer's requirements. It also minimizes agricultural damage from harsh weather and heavy rainfall by producing electricity from rainwater and solar panels and delivering information to an authorized individual.

BLOCK DIAGRAM

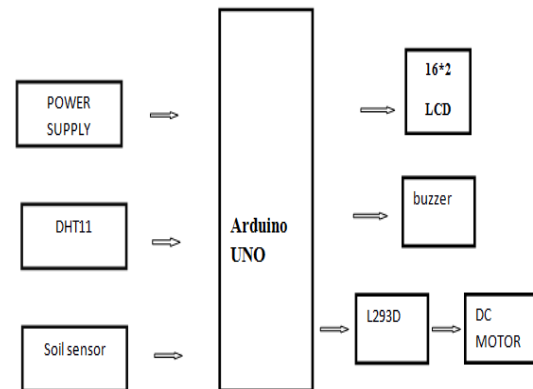

Figure 1: Block Diagram

INTRODUCTION TO EMBEDDED SYSTEMS

A computer system that is purpose-built to carry out a single or limited set of tasks, often under the restrictions of real-time computing, is known as an embedded system. As with other physical and mechanical components, it is often integrated into a whole device. A personal computer or other general-purpose computer, on the other hand, may be programmed to do a wide variety of functions. These days, many of the everyday items we use rely on embedded systems to function.

Design engineers may improve the embedded system to decrease product size and cost while boosting reliability and performance since it is devoted to certain functions. Because of their mass production, certain embedded systems are able to take advantage of cost savings. From small, handheld gadgets like digital watches and MP3 players to massive, permanently installed systems like those managing nuclear power plants, traffic lights, and industrial controls are all examples of physically embedded systems. From simple systems using a single microcontroller chip to complex systems housing several modules, peripherals, and networks in a massive chassis or enclosure, complexity may range greatly. Since most systems may be programmed in some way, the term "embedded system" lacks a precise definition. While they share some components with embedded systems, such operating systems and microprocessors, handheld computers are not technically embedded systems as they enable the loading of multiple programs and the connection of peripherals.

Computer hardware and software, either fixed in capability or programmable, particularly intended for a certain sort of application device—this is what's called an embedded system. Embedded systems may be found in a wide variety of objects, including but not limited to: vehicles, medical devices, cameras, home appliances, aircraft, vending machines, toys, and, of course, cellular phones and personal digital assistants. A programming interface is given to programmable embedded devices, and programming for embedded systems is a niche field in and of itself. Embedded Java and Windows XP Embedded are two examples of embedded-specific operating systems and language platforms. On the other hand, certain budget consumer goods include integrated application and operating system components, employ very cheap microprocessors, and have limited storage space. Instead of being loaded into RAM (random access memory), as applications on personal computers are, in this situation the program is written permanently into the system's memory.

CHARACTERISTIC OF EMBEDDED SYSTEM

- **Speed (bytes/sec):** Should be high speed
- **Power (watts):** Low power dissipation
- **Size and weight:** As far as possible small in size and low weight
- **Accuracy (%error):** Must be very accurate
- **Adaptability:** High adaptability and accessibility
- **Reliability:** Must be reliable over a long period of time

APPLICATIONS OF EMBEDDED SYSTEMS

Here, in the Embedded World, we are living. The smooth operation of the various embedded goods that surround you is crucial to your day-to-day existence. In your living room, you have a TV, radio, and CD player; in your kitchen, you have a washing machine or microwave oven; and at your office, you have card readers, access controllers, and palm devices that let you do a lot. In addition to all of this, your automobile has a plethora of built-in controls that handle functions between the bumpers, most of which you probably don't give a second thought to.

- **Robotics:** industrial robots, machine tools, Robocop soccer robots
- **Automotive:** cars, trucks, trains
- **Aviation:** airplanes, helicopters
- Home and Building Automation
- **Aerospace:** rockets, satellites
- **Energy systems:** windmills, nuclear plants
- **Medical systems:** prostheses, revalidation machine.

MICROCONTROLLER VERSUS MICROPROCESSOR

When comparing microprocessors and microcontrollers, what are the key differences? When people talk about microprocessors, they're usually referring to general-purpose CPUs like the X86 series from Intel (8086, 80286, 80386, 80486, and the Pentium) or the 680X0 series from Motorola (68000, 68010, 68020, 68030, 68040, etc.). In addition to lacking on-chip I/O ports, these microprocessors also lack random-access memory (RAM). Because of this, they are often called general-purpose microprocessors. Designing a working system around a general-purpose CPU like the 68040 or Pentium requires

the addition of extra components like as RAM, ROM, I/O ports, and timers. Though these systems are more costly and cumbersome due to the inclusion of external RAM, ROM, and I/O ports, they provide the benefit of being versatile in that the designer may choose the quantity of RAM, ROM, and I/O ports required for the work at hand. Microcontrollers are an exception to this rule. On a single chip, you'll find a microprocessor, random access memory (RAM), read/write (ROM), input/output (I/O) ports, and a timer in a microcontroller. So, since the CPU, random access memory (RAM), read/write memory (ROM), input/output (I/O) ports, and timer are all integrated into a single chip, the designer is unable to include any more memory, I/O ports, or timer into the product. Because of its set quantity of on-chip ROM, RAM, and number of I/O ports, microcontrollers are perfect for many applications where space and cost are important considerations. It is not necessary to have a 486 or even an 8086 CPU for many applications; for instance, a TV remote control. Typically, these programs will need some kind of input/output function in order to read signals and toggle bits.

MICROCONTROLLERS FOR EMBEDDED SYSTEMS

The word "Embedded System" appears often in articles on microprocessors. The embedded system products heavily use microprocessors and microcontrollers. The microprocessor (or microcontroller) in an embedded system product is designed to do a single job exclusively. An embedded system is best shown by a printer since its central processing unit (CPU) is dedicated to a single function: data retrieval and printing. Take a Pentium based PC as an example. Word processors, print servers, bank teller terminals, video game consoles, network servers, and Internet terminals are just a few of the many uses for personal computers. A wide range of apps may have their software loaded and executed. Obviously, a computer's random access memory (RAM) and operating system are what allow it to execute applications and do all those other things. This robot's fire sensor sends a signal to the microcontroller the second it detects fire. One piece of application software is usually burnt into ROM in an embedded device. Many different embedded goods, such a keyboard, printer, modem, disk controller, sound card, CD-ROM drive, mouse, and so on, are either built into or attached to an x86 PC. A single-purpose microcontroller is housed inside each of these peripherals.

ARDUINO UNO BOARD:

One such microcontroller board is the Arduino Uno, which uses the ATmega328. A 16 MHz ceramic resonator, 6 analog inputs, 14 digital I/O pins (including 6 PWM outputs), 1 USB port, 1 power connector, 1 ICSP header, and 1 reset button are all part of it. All you need is a USB cable, an AC-to-DC converter, or a battery to get it going; it comes with everything you need to support the microcontroller.

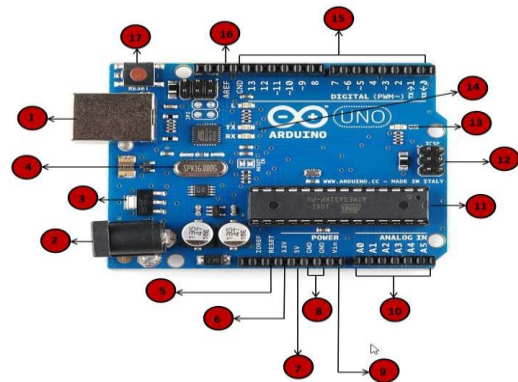

Figure 2: Arduino uno board

In contrast to all of its predecessors, the Uno does not have the FTDI USB-to-serial driver chip. As an alternative, it makes use of USB-to-serial converters coded into the Atmega16U2 (Atmega8U2 up to version R2).

HARDWARE COMPONENTS

POWER SUPPLY UNIT

The power supply for this system is shown below.

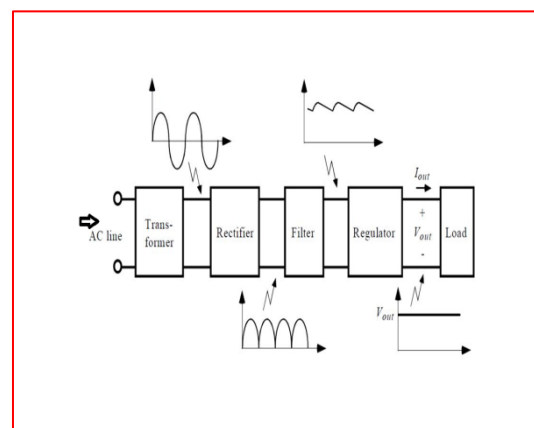

Figure 3.power supply

Transformer:

A transformer is a static electrical device that changes the voltage level but not the frequency.

Transformers come in two main varieties. first, a step-up transformer 2. Lowering transformer The frequency of the input voltage is unaffected by the step-up transformer's ability to transform it from low to high voltage. A step-down transformer maintains the original frequency while transforming high voltage into low voltage. As you can see below, this project makes use of a step-down transformer, which can change 230V AC to either 12V AC or 5V AC.

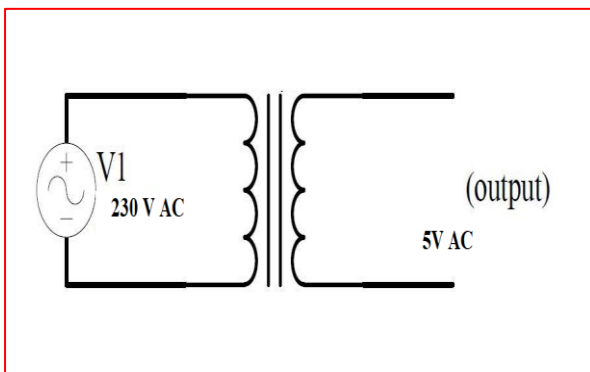
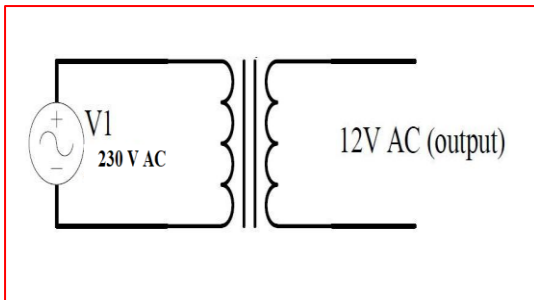

Figure 4 :Transformers

Diodes:

Only one path of electrical current may pass through a diode. Current may flow in either direction, as shown by the arrow in the circuit symbol. Originally termed valves, diodes are essentially an electrically enhanced version of the mechanical component.

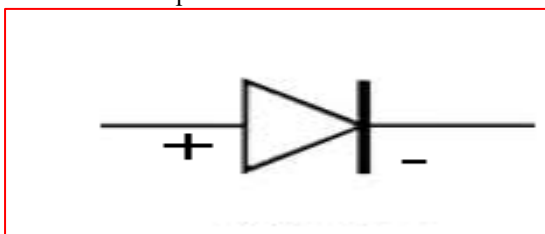

Figure 5: Diode Symbol

One kind of electrical component that restricts current flow is the diode. The diode is referred to as "forward-biased" while facing this way, and the signal is just attenuated by around 0.7V. No current

will flow through a diode that is "reverse-biased" when the current is applied in the other direction.

Rectifier

A rectifier's job is to change the phase of an alternating current (AC) waveform so that it appears as a direct current (DC) waveform. The terms "half-wave" and "full-wave" describe two distinct types of rectifiers. Diodes are used in both devices to convert AC current into DC current. The Half-Wave Rectifiable The graphic shows that the half-wave rectifier is the simplest rectifier type since it only employs one diode.

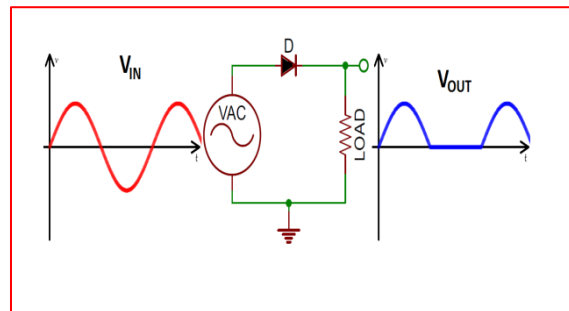

Figure 6 :Half Wave Rectifier

LIQUID CRYSTAL DISPLAY

Thin and flat, a liquid crystal display (LCD) is made up of an arrangement of color or monochrome pixels that are placed in front of a light source or reflector. The components of each pixel are a pair of polarizing filters with orthogonal polarity axes, a column of liquid crystal molecules suspended between two transparent electrodes, and an image sensor. In the absence of the liquid crystals, light would not pass through them. By modifying the polarization of the light entering the first filter, the liquid crystal allows light to pass through two filters.

Programs can't talk to the outside world unless they have input and output devices, which are dependent on people talking to one other. One common add-on for controllers is an LCD screen. The most common kinds of displays that are typically connected to the controllers are 16x1, 16x2, and 20x2 LCDs. This amounts to sixteen characters per line. Each line in the first set has sixteen characters, while lines in the second set include twenty. Microcontroller devices often make use of "smart LCD" panels to display visual data. Displays based on the LCD NT-C1611 module are a fantastic option since they are inexpensive, easy to use, and can provide a readout using the display's 5X7 dots plus pointer. Mathematics symbols and the standard ASCII character set are used. The LCD requires a power supply of +5V and ten input/output lines for an 8-bit data bus: RS, RW,

D7, D6, D5, D4, D3, D2, D1, and D0. In order to implement a 4-bit data bus, only six more lines—RS, RW, D7, D6, D5, and D4—are required, in addition to the supply lines. Since the data lines are tri-state, they continue to operate normally even when the LCD screen is turned off.



Figure 7: 2x16 LCD Display

HUMIDITY SENSOR

A humidity sensor, sometimes called a hygrometer, monitors and routinely reports the relative humidity in the air. They may be used in houses for persons with diseases impacted by humidity; as part of home heating, ventilation, and air conditioning (HVAC) systems; and in humidors or wine cellars. Humidity sensors may also be utilized in autos, office and industrial HVAC systems, and in meteorology stations to record and forecast weather.

A humidity sensor monitors relative humidity. In other words, it's a dual-purpose thermometer and humidity gauge. As a percentage, relative humidity measures how much moisture is really in the air as compared to the maximum amount that air at that temperature can contain. Relative humidity varies as a function of temperature because warmer air can retain more moisture. "Capacitive measurement" describes the most used kind of humidity sensor. An electrical field that forms between two neighboring conductors—a phenomenon known as electrical capacitance—is essential to this arrangement. Two metal plates sandwiched by a polymer layer that does not conduct electricity make up the sensor. When airborne moisture settles within the film, it alters the voltage differential between the two plates by a little amount. Digital values indicating the air humidity are produced from the voltage fluctuations.

SOIL SENSOR

For the purpose of measuring the soil's moisture content, the soil moisture sensor is a typical component of smart agriculture and other garden automation systems. It has four pins, two of which are connected to the power source (Vcc and Gnd). Two more pins serve as outputs: digital (D0) and analog (A0). In the event that the soil moisture level above the predetermined threshold, a low logic signal will be produced via the digital pin (D0). By adjusting the inbuilt potentiometer, the sensor module's threshold value may be adjusted. You can roughly determine the soil's moisture content using the analog output pin.

You will get one soil moisture sensor module along with the sensor probes and measurement module when you make a purchase. Submerging the sensor probe in the dirt and connecting it to the measuring module is the process. The measurement module will use the LM393 OP-Amp comparator to compare the measured value with a threshold value, which can be adjusted using a 10k pot, and then output the result on the digital pin. Below you can see the sensor probe and the measuring module.

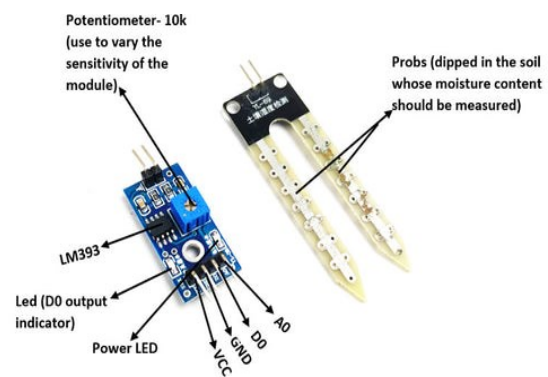

SOFTWARES

Introduction to Arduino IDE

The Arduino platform is an open-source, user-friendly hardware and software environment for prototyping. It is comprised of a programmable circuit board (also called a microcontroller) and an Integrated Development Environment (IDE) called Arduino that is pre-made for writing and uploading code to the physical board. The main characteristics are:

- Many sensors can send signals in digital or analog formats to Arduino boards, which may then be used to activate motors, control LEDs, establish connections to the cloud, and much more.
- The Arduino IDE (also called "uploading software") allows you to command your board's operations by communicating with the

microcontroller on the board.

- A separate device, known as a programmer, is not required to load fresh code into an Arduino board, in contrast to most prior programmable circuit boards. The usage of a USB connection is all that is required.
- The Arduino IDE employs a streamlined version of C++, which facilitates programming learning. Last but not least, Arduino offers a standardized form factor that simplifies the microcontroller's tasks.

Now that we know what the Arduino UNO board is and how it works, we can go on to setting up the Arduino IDE. As soon as we figure this out, we can upload our software to the Arduino board.

RESULTS

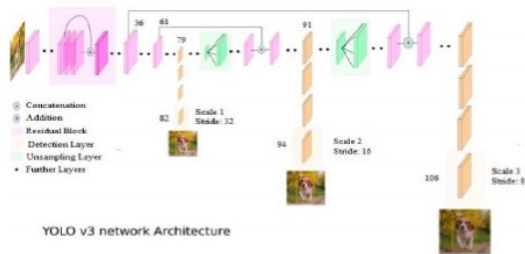
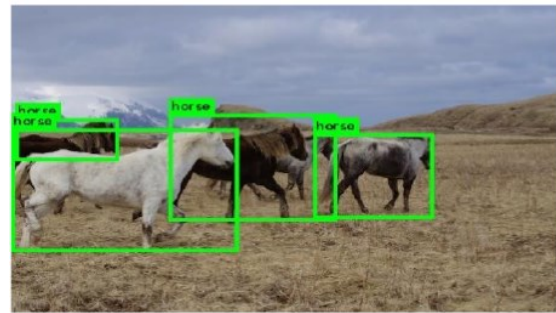
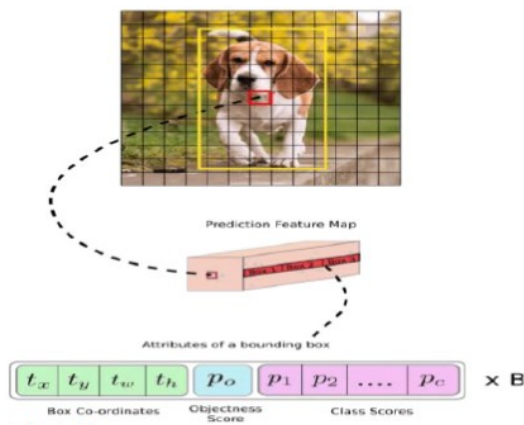

Image Grid. The Red Grid is responsible for detecting the dog



CONCLUSION

It is claimed that irrigation systems can function independently thanks to the rapid data transmission made possible by the Internet of Things. One major perk of the Internet of Things is that data may be sent even while users aren't online; once they are online, they can access the data that has already been sent. They can track daily atmospheric changes to boost plant output. To top it all off, it cuts pesticide use by 30–40%. The community is now focusing on the problem of animal and plant fires as their top priority. This problem requires immediate attention since there is no workable solution to it at the moment. Therefore, our research aims to remedy this issue, which has substantial social relevance. Farmers will be able to safeguard their fields and crops, save financial losses, and avoid fruitless field protection efforts thanks to our study. Increased agricultural output will also boost their economic well-being. In a future built on image processing, animals may be tracked via cameras, and the system can respond quickly to their approach to the farm thanks to wireless networks. Additionally, a security system may be used in conjunction with wireless networks, such as laser wireless sensors, to recognize animals.

REFERENCE

1. V. Bavane, A. Raut, S. Sonune, A. Bawane, and P. Jawandhiya, "Protection of crops from wild animals using intelligent surveillance system."
2. R. Vigneshwar and R. Maheswari, "Development of embedded based system to monitor elephant intrusion in forest border areas"

using internet of things,” International Journal of Engineering Research, vol. 5, no. 7, pp. 594–598, 2016.

3. T. Day and R. Mac Gibbon, “Multiple-Species Exclusion Fencing and Technology for Mainland Sites.”, Project Report published by National Wildlife Research Centre, 2007.