



**International Journal of
Engineering Research and Science & Technology**

ISSN : 2319-5991



www.ijerst.com

Email: editor@ijerst.com or editor.ijerst@gmail.com

Boosting Efficiency using PAPR Using the Selective Mapping (SLM) Technique to Reduce in MIMO-OFDM Systems

Mr. D. Veeranna, Dr. K. Amit Bindaj, Ms. K. Sunitha, Ms. Y. Anitha

² ASSOC.PROFESSOR, ^{1,3,4} ASSIT.PROFESSOR

Department of ECE, SWARNA BHARATHI INSTITUTE OF SCIENCE & TECHNOLOGY (SBIT), Pakabanda Street, Khammam - 507 002. Telangana, India.

ABSTRACT

5G requires very advanced communication methods to increase spectrum efficiency. Both Orthogonal Frequency Division Multiplexing (OFDM) and Multiple Input Multiple Output (MIMO) have found application due to their superior performance. This system makes use of MIMO-OFDM methods to boost its performance. Extremely high signal amplitudes are possible with OFDM due to the huge number of separate subcarriers. Spectral efficiency is maximised using this kind of multicarrier modulation. Nevertheless, a high PAPR is an outcome of the OFDM signal's robust power peaks. A higher BER and worse system performance are the results of such a high PAPR. As the number of routes changes, this work focusses on the Selective Mapping Technique (SLM) that uses the Complementary Cumulative Distribution Function (CCDF). Using SLM becomes effective when there are a lot of subcarriers. The SLM approach is able to reduce the peak-to-average power ratio in MIMO-OFDM. The main problem with SLM is that it relies on auxiliary data bits to find the receiver's real data bits. Because signal detection is possible with SLM that does not include any auxiliary data. Clearly, PAPR is inversely proportional to route numbers, according to the simulation findings.

KEYWORDS: MIMO-OFDM, PAPR, Complimentary Cumulative Distribution Function, Selected Mapping.

INTRODUCTION

Higher data speed is becoming a more common demand with each passing day. Enhanced communication transmission techniques have been used to provide high-speed connectivity. MIMO-OFDM is a high-speed communication transmission technology that provides immunity to frequency selective fading, great spectral efficiency and power efficiency for wireless wideband applications such as WLANs, 4G and 5G wideband wireless communications, MIMO-OFDM is primarily used as an air interface. MIMO is a system for enhancing the ability of a radio link with several transmitting and receiving antennas. It is used with OFDM to improve system efficiency. For wideband digital communication, OFDM has become a popular technology for transporting data over several simultaneous data streams and channels. At a low bit rate, each subcarrier is modulated using a typical modulation approach. The transmitter input bits in MIMO-OFDM are separated into frames of bit. The OFDM signal has an enormous Peak to Average Power Ratio (PAPR), which is a major disadvantage of the MIMO-OFDM system (PAPR).

Many strategies for determining the OFDM's PAPR problem can be divided into two categories: 1. Distortion-based techniques and 2. Redundancy-based techniques. By adding up some deformities to the subcarrier signal points, a distortion-based approach lowers PAPR of the OFDM symbol. Both out of band and PAPR can be suppressed with a recursive clipping and filtering procedure. Tone injection (TI), selective mapping (SLM), and partial transmit coding are illustrations of redundancy-based coding (PTS). Different alternatives for lowering the PAPR are there, however either the complexity or redundancy are considerable, or the PAPR improvements are minor. SLM outperforms PTS in terms of data vectors, despite the fact that their profits are equal. PTS complexity improves with number of sub-blocks. SLM is the most advantageous approach of all because it is easy to adopt, doesn't cause any abnormalities to the signal transmitted, and that reduces PAPR to a satisfactory level.

blocks is then obtained using IFFT, with x^u expressing candidate signals. Finally, for transmission, the signal with the lowest PAPR is chosen, as shown in figure 1.

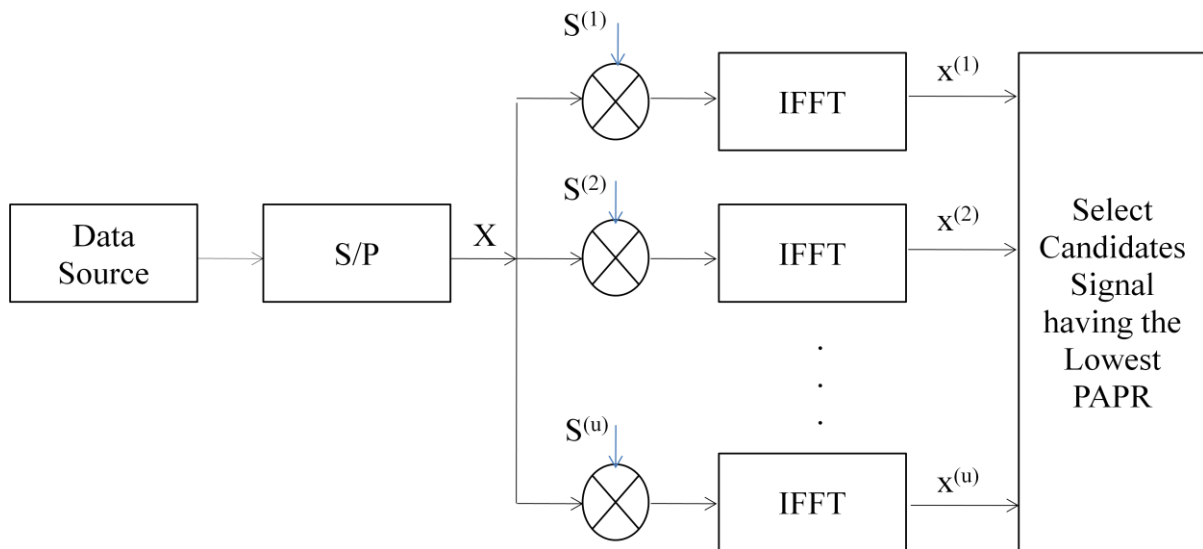

Figure 1: Block diagram of Selected Mapping (SLM) technique

The receiver needs side information in order to correctly recuperate the received signals. When binary bits are employed, $\lceil \log_2 S \rceil$ bits are sufficient to describe this side information. With the sending signal, the side information is made available.

SLM can be applied to any signal constellation with any number of sub-carriers. With moderate complexity, it gives substantial improvement. To maintain side information, channel coding is required. After executing the dot product, it is important to determine

which sequence is related to the shortest PAPR with M distinct candidates at the receiver in order to demodulate the incoming signal precisely. As a result, the information that must be learned by receiver about the specified sequence of phase vector P_m and verify that it is accurately received.

An appealing technique is to send the branch number m 's entire sequence to the receiving end as side information. In practise, however, the operation does not always necessitate the delivery of the complete vector sequence. It can be accomplished instead by providing the vector sequence's route number. This is only conceivable if the receiving end can use a look-up table or another way to re-establish the random phase sequence P_m . Channel coding is utilised to ensure a reliable communication because side information is critical in order to restore the signal at receiver's end. Once channel coding technique is offered, any additional side information is not essential, throughout the transmission process. All alternative paths are discovered in this way, and the most likely one is chosen as the best, at the receiving end.

SIMULATION OF SLM SCHEME

Using Matlab, an assessment of parameters that may influence PAPR reduction performance is carried out in this paper. According to the fundamentals of the SLM algorithm, the M , route number and N , subcarrier number has an impact on the effectiveness of SLM to reduce PAPR. As a result, simulations with various M and N values will be carried out, with the results revealing certain desirable features of signals expressing the same information.

Parameter	Value/Description
No. of random data bits	10000
Modulation Technique	QPSK
Over Sampling factor (Case 1)	8
Route Number (M) (Case 1)	4, 8, 16 & 32
Route Number (M) (Case 2)	8
Number of Subcarriers (N) (Case 2)	32, 64, 128 & 256

Table 1: Important Parameters used for the simulation of SLM scheme

Case 1: Analysis of PAPR reduction performance with various M values when N is kept constant at 128. Define

To begin, the rotation factor is described as $S_{m,n} \in [\pm 1, \pm j]$ from the standpoints of intricacy and practicability. When compared to conducting miscellaneous complex multiplication, this drastically reduces computation complexity. The process is repeated 10000 times, with an using a QPSK mapping modulation technique for each sub-carrier and an over-sampling ratio of 8. The parameters utilised as route numbers are $M=4$, $M=8$, $M=16$, and $M=32$. Figure 2 shows that the suggested SLM method reduces PAPR more

effectively than the real OFDM signal, which is unaffected by the PAPR control scheme. The likelihood of a substantial PAPR is substantially diminished. Raising M enhances PAPR reduction performance. Comparing CCDF curves with different M values is possible with a chance of 1%. For example $M=4$, the PAPR value is around 2 dB lower than for case $M=1$. Under identical circumstances, the PAPR value for case $M=32$ is about 3 dB lower than case $M=1$. Nevertheless, comparing the curves for $M=16$ and $M=32$ reveals that the performance gap between the two would be smaller than 0.5 dB. This demonstrates that the performance of OFDM signal PAPR reduction will not be much enhanced, and that raising the value of M (for example, to $M \geq 8$) will not lead to a linear improvement.

Furthermore, it is evident that the execution time will grow in proportion to the value of M . Since this enhances system performance and prevents adding too much computational complexity, we are able to effectively save precious resources when we employ $M=8$ in practice.

Figure 2: Comparison of PAPR reduction performances with different values of M .

Case 2: Analysis of PAPR reduction capability with various N values, while M is kept constant at 8.

In this situation, the number of OFDM signal frames M is set to 8 and the number of sub-carriers N is set to 256, 128, 64, and 32, respectively. Figure 3 shows the CCDF curve of the original sequence's PAPR as a point of comparison to those who used the SLM technique.

Even though the number of carriers doubled after the adoption of the SLM method, the PAPR reduction performance of OFDM signal is not significantly reduced when the total number of sub-carriers exceeds 128, as shown in Figure 3.

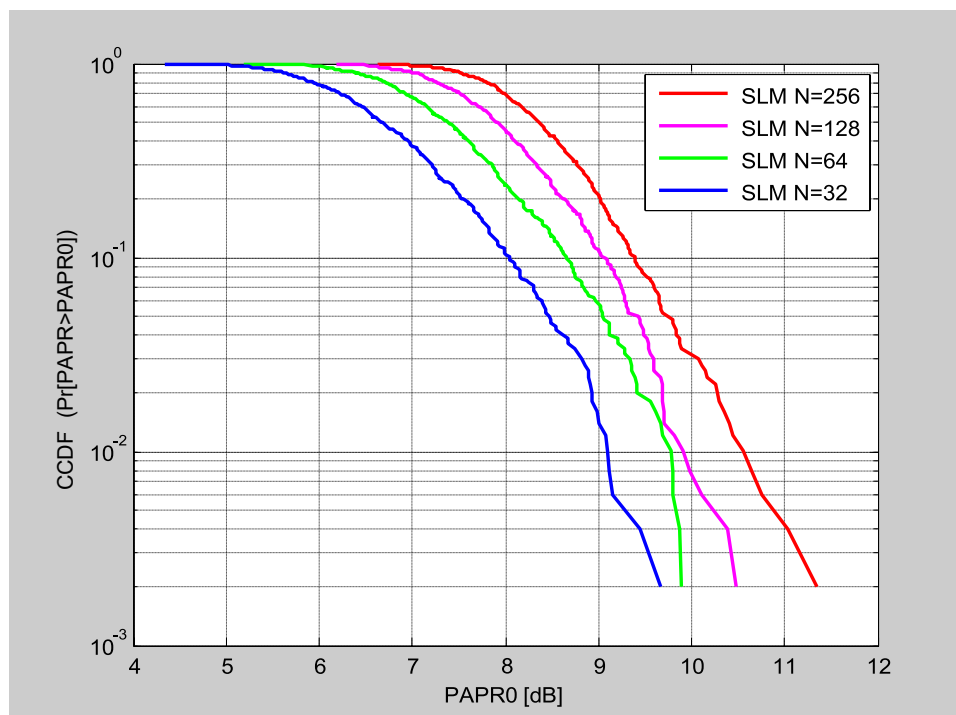

Figure 3: Comparison of PAPR reduction capability with various N values.

CONCLUSION

The results of comparing and evaluating the aforementioned forms of simulation data led to these conclusions:

1. An OFDM system's PAPR distribution is greatly enhanced by the SLM approach, which lowers the probability of displaying a high peak power signal. Increasing the amount of OFDM signal frames is strongly advised. In an effort to increase complexity while improving PAPR reduction capabilities to a certain extent.
2. OFDM systems with varying carrier counts may make advantage of the SLM approach due to its adaptability, which allows it to be applied to FFT frames of any length. This method is recommended for OFDM systems with more than 128 sub-carriers.
3. By successfully reducing the PAPR, the SLM approach significantly enhances the performance of an OFDM system. Having said that, its price tag and intricate design are obvious. The SLM approach requires the transmitter to always calculate M group IFFTs, as opposed to only one group IFFT as is typical in OFDM systems. IFFT is made of Tackling these problems and making OFDM practicable for real-world deployments requires reducing the computational complexity. Based on this, we may say that M=8 is an optimal compromise between theoretical computer complexity and practical performance.

REFERENCES

- First published in June 2007 in the Proceedings of the IEEE International Conference on Communications (ICC '07), this paper by B. K. Knoo, S. Y. Le Goff, C. C. Tsimenidis, and B. S. Sharif discusses "OFDM PAPR reduction using selected mapping without side information."
2. In the 2008 issue of the EURASIP Journal on Wireless Communications and Networking, Siegl and Fischer discuss "Partial transmits sequences for peak-to-average power ratio reduction in multiantenna OFDM" (Volume 8, Article ID 325829). John Wiley & Sons (Asia) Pte Ltd., 2010 published the work of Yong Soo Cho, Jaekwon Kim, Won Young Yang, and Chung G. Kang titled "MIMO-OFDM Wireless Communications with MATLAB."
- The paper "SLM-BASED RADIX FFT FOR PAPR REDUCTION IN OFDM systems" was written by Ghassemi and T. A. Gulliver in 2007. Pages 1031–1034 of the 2007 IEEE International Conference on Signal Processing and Communications (ICSPC 2007).
5. A Modified Genetic method PTS method for PAPR Reduction in OFDM Systems, by H. Liang, Y. R. Chen, Y. F. Huang, and C. H. Cheng (2009). Volume 15, Issue 2, Pages 182-185, 2009 Asia-Pacific Communications Conference Proceedings (APCC 2009). Volume 1, Issue 8, November 2011, ISSN 2222-9833, "Comparative Study of PAPR Reduction Techniques in OFDM" by Md. Ibrahim Abdullah, Md. Zulfiker Mahmud, Md. Shamim Hossain, and Md. Nurul Islam
8. "An Investigation of Peak-to-Average Power Reduction in MIMO- OFDM Systems" by Wang Yi Gu linfeng, published in October 2009 by the Blekinge Institute of Technology. In their 2007 paper "Improved SLM for PAPR Reduction in OFDM System," Peng Cheng, Yue Xiao, Lilin Dan, and Shaoqian Li discuss an enhanced SLM.
9. In their 2014 July article for the International Journal of Advanced Research in Computer Engineering & Technology, Tincy Marry Mathew and Ekant Sharma discuss how they reduced

PAPR performance in an Alamouti coded MIMO-OFDM system by employing BPSK modulation and certain mapping approaches.

10. "A Survey on the Effects of High PAPR and PAPR Reduction Techniques in OFDM Systems" (Ciya Thomas and C. D.), International Journal of Advanced Research in Computer Science and Software Engineering (2015).

11. "BER analysis of PAPR reduction techniques in SFBC OFDM system: A review" by P. N. Kota, A. N. Gaikwad, and B. P. Patil was published in December 2015 by IEEE.

12. In an article published online in March 2015 by I. J. Wireless Technologies, Md. Salim Raja discusses the use of a sequential phase sequence SLM based transceiver to reduce the OFDM signal without side information.

13. "SLM Peak-Power Reduction using Explicit Side Information," IEEE Communication Letters, Vol. 5, No. 5, June 2001, by H. Breiling, S. H. Muller-Weinfurter and J. B. Huber.

14. In 2016, Ni, C., Ma, Y., and Jiang, T. In order to decrease PAPR in large-scale multi-user MIMO-OFDM systems, a new adaptive tone reservation approach has been proposed. Wireless Communications Letters, 5(5), 480-483, published by IEEE.

15. In 2015, Taspinar and Yildirim published a study. Performance decrease in OFDM and MIMO-OFDM systems using a new parallel artificial bee colony technique and the SLM scheme. 19(10), 1830–1833, IEEE Communications Letters.

In order to reduce PAPR in OFDM systems, Liu et al. (2013) proposed a threshold-based piecewise companding transform. Volume 20, Issue 2, Pages 1–18, Journal of China's Posts and Telecommunications Universities.