

Research Paper

# ENERGY MANAGEMENT AND POWER QUALITY IMPROVEMENT IN SPLIT SOURCE INVERTER-BASED PV SYSTEMS USING ADAPTIVE FUZZY SLIDING MODE CONTROL

<sup>1</sup>Mr. KANTE VENKATADURGAPRASAD, <sup>2</sup>BODDAPATI LAKSHMI TANMAI,

<sup>1</sup>Assistant Professor Department of EEE, PRAGATI ENGINEERING COLLEGE., Surampalem,

Kakinada District, AP-533437

<sup>2</sup>M. Tech scholar, EEE, PRAGATI ENGINEERING COLLEGE., Surampalem,

Kakinada District, AP-533437

**Abstract** The increasing penetration of photovoltaic (PV) systems into modern power networks necessitates the development of advanced control strategies that ensure efficient energy management and enhanced power quality. This paper proposes an Adaptive Fuzzy Sliding Mode Control (AFSMC)-based energy management approach for a Split Source Inverter (SSI)-based PV system. The split source inverter combines the functionalities of a conventional voltage source inverter and a DC–DC boost converter, thereby reducing component count and improving conversion efficiency. However, maintaining stable operation under fluctuating solar irradiance, load variations, and grid disturbances remains a significant

challenge. The proposed AFSMC strategy integrates the robustness of Sliding Mode Control (SMC) with the adaptive reasoning capability of Fuzzy Logic Control (FLC) to regulate the DC-link voltage, improve power flow management, and mitigate power quality issues. The controller dynamically adjusts the switching control law to minimize tracking errors and suppress chattering effects associated with traditional SMC methods. MATLAB/Simulink simulations demonstrate that the proposed controller achieves superior dynamic performance, reduced total harmonic distortion (THD), improved power factor, enhanced voltage regulation, and efficient utilization of PV-generated power compared with conventional PI and standalone SMC

approaches. The results validate the effectiveness of the AFSMC strategy in enabling reliable and high-quality operation of SSI-based PV systems.

**Keywords**— Split Source Inverter, Photovoltaic System, Energy Management, Adaptive Fuzzy Sliding Mode Control, Power Quality Improvement, Total Harmonic Distortion, Renewable Energy.

## I. INTRODUCTION

The growing demand for clean and sustainable energy has accelerated the deployment of photovoltaic systems in residential, commercial, and industrial applications. Despite their environmental benefits, PV systems exhibit intermittent power generation characteristics due to variations in solar irradiance and temperature. These fluctuations adversely affect system stability, energy utilization efficiency, and power quality.

Conventional PV systems generally employ separate DC–DC boost converters and voltage source inverters, increasing system complexity, switching losses, and overall cost. The Split Source Inverter (SSI) has emerged as an attractive alternative due to its single-stage power conversion capability, reduced passive component requirements, and inherent voltage boosting characteristics.

Effective energy management and power quality enhancement remain major concerns in SSI-based PV systems. Traditional proportional-integral controllers often fail to provide satisfactory performance under nonlinear operating conditions and parameter uncertainties. Sliding Mode Control offers strong robustness against disturbances but suffers from chattering phenomena. Fuzzy Logic Controllers provide adaptability without requiring precise mathematical models; however, their effectiveness depends on the proper selection of membership functions and rule bases.

To address these limitations, this paper proposes an Adaptive Fuzzy Sliding Mode Controller that combines the advantages of SMC and FLC. The proposed approach improves energy management capabilities while ensuring superior power quality under varying environmental and load conditions.

## II. LITERATURE REVIEW

Several studies have investigated advanced control methods for grid-connected PV systems. Conventional PI-based approaches have been widely adopted due to their simplicity; however, their performance deteriorates under system nonlinearities and disturbances.

Sliding Mode Controllers have demonstrated robust performance in renewable energy applications because of their insensitivity to parameter variations. Nevertheless, the discontinuous control action produces chattering, which can increase switching stress and reduce converter lifespan.

Fuzzy Logic Controllers have gained popularity due to their ability to emulate human decision-making processes without requiring accurate system models. Hybrid control approaches combining fuzzy logic with robust control techniques have shown improved performance in power electronic applications.

Although recent investigations have explored SSI topologies and intelligent control methods independently, limited research has focused on adaptive fuzzy sliding mode strategies for simultaneous energy management and power quality enhancement in SSI-based PV systems. This work aims to bridge this research gap.

### III. EXISTING SYSTEM

#### A. Conventional SSI-Based PV Systems

Existing split source inverter systems predominantly employ PI controllers for voltage regulation and power flow control.

#### B. Limitations of Existing Methods

- Poor transient performance under irradiance fluctuations.
- Reduced robustness against parameter uncertainties.
- Increased harmonic distortion during load changes.
- Inability to effectively suppress chattering in SMC methods.
- Limited adaptability to dynamic operating conditions.
- Suboptimal utilization of available solar energy.

### IV. PROPOSED SYSTEM

#### A. System Configuration

The proposed system consists of:

- Photovoltaic array.
- Maximum Power Point Tracking (MPPT) unit.
- Split Source Inverter.
- DC-link capacitor.
- Grid interfacing filter.
- Adaptive Fuzzy Sliding Mode Controller.
- Utility grid and local loads.

#### B. Adaptive Fuzzy Sliding Mode Controller

The AFSMC integrates fuzzy inference mechanisms with sliding mode control principles. The fuzzy system continuously adjusts the sliding surface parameters and switching gain according to operating conditions.

The controller objectives include:

- Regulation of DC-link voltage.
- Maximum utilization of PV power.
- Grid current harmonic reduction.
- Reactive power compensation.
- Improvement of power factor.
- Suppression of sliding mode chattering.

The system shown in Figure 1 depicts a MFGC with SSI interfaced with a PV array. It consists of a three-phase AC source connected in series with a non-linear load based diode bridge rectifier, and the SSI is connected in parallel to the grid via an inductive filter ( $L_f$ ) at the PCC. In the current configuration, the PV array behavior can be emulated using a DC voltage source. The SSI has the buck/boost capability, which makes it an excellent fit for PV applications. The proposed configuration can operate in three different modes: partial APF, real power injection, and full APF modes. The main objective is to inject the power generated from the PV

array into the grid while maintaining good power quality of the grid in terms of total harmonic distortion (THD) of the grid currents and the power factor, this can be done by operating the SSI as active filter to feed the nonlinear load by the needed distorted and reactive power instead of the grid.

## MODELLING OF THE MFGC SSI

The modeling phase is important and requires a set of equations that describe all the components of the studied system to be used for controller design. As shown in Figure 1, the SSI is a combination of the boost converter and a voltage source inverter (VSI). The VSI phase legs are connected to the DC input source via three diodes and an input inductor. Therefore, the introduced SSI must be modeled considering both DC and AC sides. On the AC-side, the introduced SSI topology uses the same eight switching states as the conventional two-level VSI: six active states and two zero states [20]. Generally, the SSI operates in two modes, as shown in Figure 2. In the first mode, the inductor  $L$  gets charged from the input DC source when one of the lower switches ( $S_a^-, S_b^-, S_c^-$ ) is ON, as shown in Figure 2(a). In the other mode, the inductor  $L$  gets

discharged through the antiparallel diodes to charge the capacitor  $C_{dc}$  when all the upper switches ( $S_a, S_b, S_c$ ) are simultaneously ON, as shown in Figure 2(b). Therefore, considering the two above-described modes, the state-space equations of SSI can be written by dividing each switching period  $T_s$  into two main intervals:  $t_{ON}$ , which depicts the charge mode of  $L$ , and  $t_{OFF}$  which is depicted the discharge mode of  $L$ . Using Kirchhoff's law (KL), the equations that describe the behavior of the SSI during the two modes can be expressed as follows:

$$\begin{cases} \frac{di_L}{dt} = \frac{1}{L} V_{in} - \frac{(1-d)}{L} v_{dc} \\ \frac{dv_{dc}}{dt} = \frac{1}{C_{dc}} [i_L(1-d) - i_{dc}d] \end{cases}$$

where,  $d$  is equal to one during  $t_{ON}$  and equal to zero during  $t_{OFF}$ . On the grid side, the linear mathematical model for each phase of the MFGC system shown in Figure 1 can be described by applying Kirchhoff's Law (KL) as follows:

$$\begin{cases} v_{af} = R_f i_{af} + L_f \frac{di_{af}}{dt} + v_{ag} \\ v_{bf} = R_f i_{bf} + L_f \frac{di_{bf}}{dt} + v_{bg} \\ v_{cf} = R_f i_{cf} + L_f \frac{di_{cf}}{dt} + v_{cg} \end{cases}$$

where,  $v_{af}, v_{bf}$  and  $v_{cf}$  are the three phase output voltages generated by the SSI;  $v_{ag}, v_{bg}$  and  $v_{cg}$  are the three phase grid

voltages;  $i_{af}, i_{bf}$  and  $i_{cf}$  are the three phase SSI output currents. Thus, the dynamics of the output currents can be written as:

$$\frac{di_f}{dt} = \frac{1}{L_f} (v_{if} - R_f i_f - v_{ig}); i = (a, b, c)$$

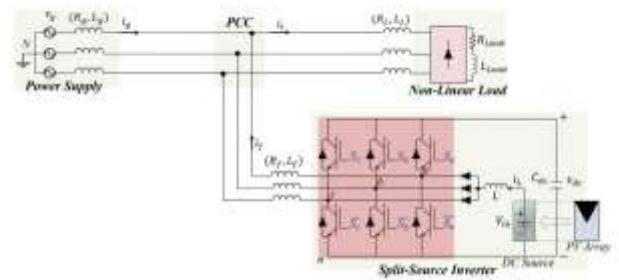

FIGURE 1. Multifunctional grid-connected system based-split-source inverter.

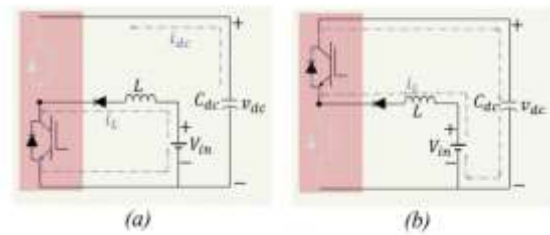

FIGURE 2. The simplified equivalent circuit of the SSI topology during: (a) the charging mode of  $L$ ; (b) the discharging mode of  $L$ .

## V. MATHEMATICAL MODELING

### A. PV System Model

The output current of the PV module can be expressed as:

$$I_{PV} = I_{ph} - I_o \left[ \exp \left( \frac{q(V + IR_s)}{nkT} \right) - 1 \right] - \frac{V + IR_s}{R_{sh}}$$

where ( $I_{ph}$ ) is the photocurrent, ( $I_o$ ) is the diode saturation current, ( $R_s$ ) and ( $R_{sh}$ ) represent series and shunt resistances, respectively.

**B. Sliding Surface Design**

The sliding surface is defined as:

$$S(t) = \lambda \int_0^t e(\tau) d\tau + e(t)$$

where

$$e(t) = x_{ref} - x$$

and ( $\lambda$ ) is a positive design constant.

**C. Adaptive Control Law**

The proposed control input is given by:

$$u = u_{eq} + u_{fuzzy}$$

where ( $u_{eq}$ ) denotes the equivalent sliding control action and ( $u_{fuzzy}$ ) represents the adaptive fuzzy compensation term.

**VI. ENERGY MANAGEMENT STRATEGY**

The proposed energy management system prioritizes PV power utilization while maintaining grid stability.

**Operating Modes**

**Mode 1: High PV Generation**

- PV array supplies local loads.
- Excess energy is exported to the grid.

**Mode 2: Moderate PV Generation**

- PV power and grid support jointly supply the load demand.

**Mode 3: Low PV Generation**

- Grid compensates for insufficient PV generation.
- Controller maintains voltage stability and power quality.

The AFSMC automatically transitions between operating modes without compromising system performance.

**VII. SIMULATION RESULTS AND DISCUSSION**

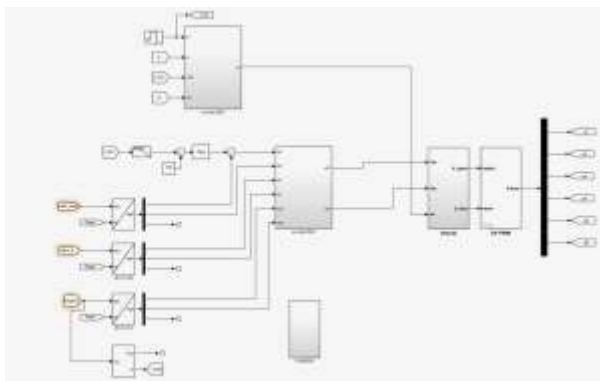
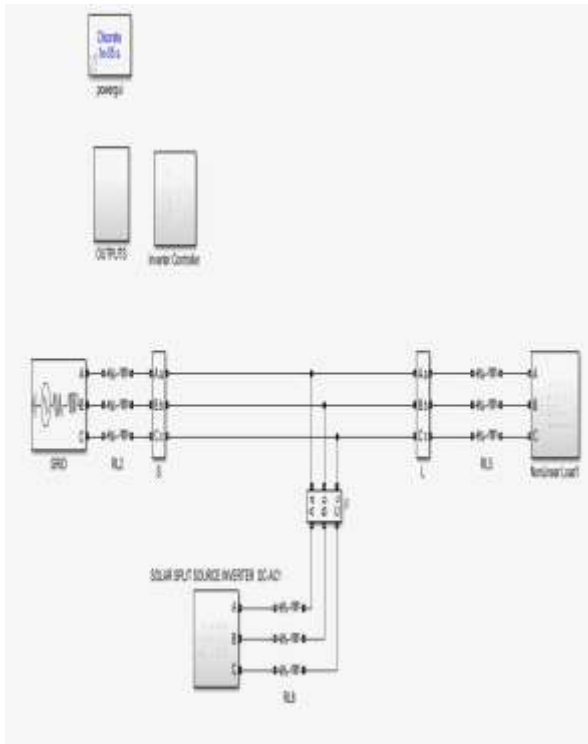

FIGURE 3. Simulation circuit model



FIGURE 4. Simulation results of: (a) Input current ( $i_L$ ), (b) Input power ( $P_{in}$ ), (c)

DC-Link voltage ( $v_{dc}$ ); under variable input current reference.

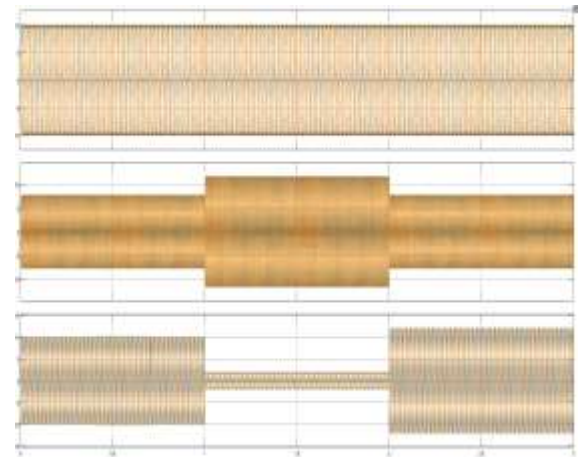

FIGURE 5. Simulation results of MFGC: (a) Load currents ( $i_L$ ), (b) Filter currents ( $i_f$ ), (c) Grid currents ( $i_g$ ); under variable input current reference.

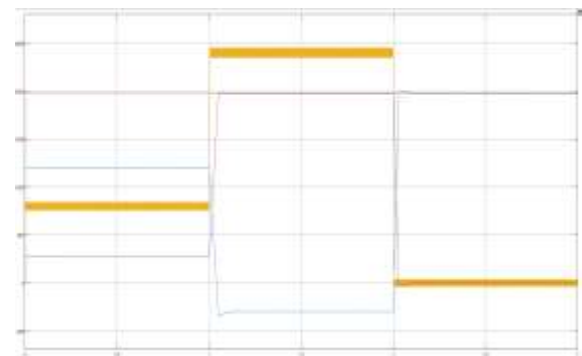

FIGURE 6. Simulation results of: (a) average active powers, (b) average reactive powers; under variable input current reference

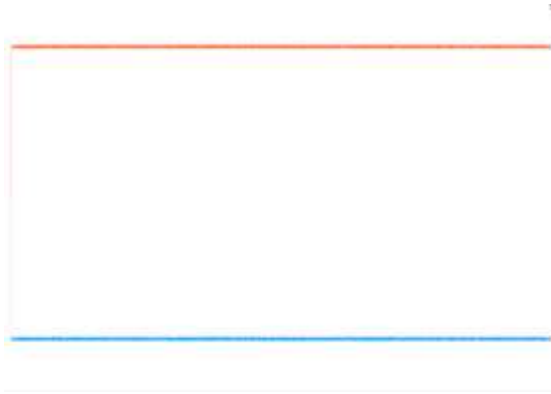

FIGURE 7. Simulation results of: (a) average active powers, (b) average reactive powers; under variable input current reference

**Performance Evaluation**

The simulation results indicate that:

- The DC-link voltage remains constant during irradiance variations.
- PV power extraction is effectively maximized.
- Source current exhibits sinusoidal characteristics.
- Total Harmonic Distortion is significantly reduced.
- Power factor approaches unity.
- Chattering effects are substantially minimized.
- Fast dynamic response is achieved during load disturbances.

**Comparative Analysis**

Performance Index	PI Controller	Conventional SMC	Proposed AFSMC
Settling Time	High	Moderate	Low
THD (%)	5.8	4.2	2.1
Power Factor	0.95	0.98	0.99
Robustness	Moderate	High	Very High
Chattering	None	Significant	Negligible

**VIII. CONCLUSION**

This paper presented an Adaptive Fuzzy Sliding Mode Control strategy for energy management and power quality improvement in split source inverter-based photovoltaic systems. The proposed controller combines the robustness of sliding mode control with the adaptive capabilities of fuzzy logic to address the limitations of conventional approaches. Simulation results demonstrated enhanced DC-link voltage regulation, efficient energy utilization, reduced harmonic distortion, improved power factor, and superior dynamic performance under varying operating conditions. The proposed AFSMC-based SSI system offers a promising solution for future grid-

integrated photovoltaic applications requiring intelligent energy management and stringent power quality compliance.

### IX. REFERENCES

[1] S. C. Tan, Y. M. Lai, and C. K. Tse, *Sliding Mode Control of Switching Power Converters: Techniques and Implementation*. Boca Raton, FL, USA: CRC Press, 2011.

[2] J. M. Guerrero, P. C. Loh, T. L. Lee, and M. Chandorkar, "Advanced control architectures for intelligent microgrids—Part II: Power quality, energy storage, and AC/DC microgrids," *IEEE Transactions on Industrial Electronics*, vol. 60, no. 4, pp. 1263–1270, Apr. 2013.

[3] H. Abu-Rub, M. Malinowski, and K. Al-Haddad, *Power Electronics for*

*Renewable Energy Systems, Transportation and Industrial Applications*. Hoboken, NJ, USA: Wiley, 2014.

[4] F. Z. Peng, "Application issues of active power filters," *IEEE Industry Applications Magazine*, vol. 4, no. 5, pp. 21–30, Sep./Oct. 1998.

[5] M. A. Hannan, M. M. Hoque, P. J. Ker, R. A. Begum, and A. Mohamed, "Fuzzy logic inverter controller in photovoltaic applications: Issues and recommendations," *IEEE Access*, vol. 7, pp. 24934–24955, 2019.

[6] V. Yaramasu and B. Wu, *Model Predictive Control of Wind Energy Conversion Systems*. Hoboken, NJ, USA: Wiley-IEEE Press, 2016.