

**International Journal of
Engineering Research and Science & Technology**



ISSN : 2319-5991

www.ijerst.com

Email: editor@ijerst.com or editor.ijerst@gmail.com

IMPROVING SHOPPING MALL REVENUE BY REAL TIME CUSTOMIZED DIGITAL COUPON ISSUANCE

VADDI SRIVALLIDEVI, Associate professor,
Department of MCA
vsrivallidevi95@gmail.com
B V Raju College, Bhimavaram

Shaik. Rehana (2285351106)
Department of MCA
rehanashaik694@gmail.com
B V Raju College, Bhimavaram

ABSTRACT

Shopping malls constantly seek innovative strategies to enhance revenue generation and improve customer engagement. One effective approach is the implementation of real-time customized digital coupon issuance systems. This paper explores the design, implementation, and impact of such a system on shopping mall revenue. The proposed system leverages advanced data analytics and machine learning algorithms to analyse shopper behaviours, preferences, and purchasing patterns in real-time. By integrating with existing customer databases and point-of-sale systems, the system can generate personalized digital coupons tailored to individual shoppers' interests and buying habits. Key features of the system include dynamic coupon creation based on real-time data analysis, targeted distribution through mobile applications or digital platforms, and seamless redemption processes at participating stores within.

Keywords: innovative strategies, revenue generation, customer engagement, digital coupon issuance, data analytics, machine learning algorithms, personalized coupons.

INTRODUCTION

Shopping malls, as key players in the retail industry, are continuously striving to innovate and adopt strategies that not only bolster revenue generation but also foster deeper engagement with their customer base [1]. In this dynamic landscape, one particularly effective approach gaining traction is the deployment of real-time customized digital coupon issuance systems [2]. These systems, enabled by advancements in technology, offer a novel way for shopping malls to interact with shoppers, providing tailored incentives that enhance the overall shopping experience [3]. In light of these trends, this paper embarks on an exploration of the design, implementation, and impact of such real-time customized digital coupon issuance systems on shopping mall revenue [4]. By delving into the intricacies of these systems, we aim to shed light on their potential to reshape the retail landscape and drive financial growth for shopping malls [5].

At the core of these systems lies a sophisticated framework that leverages advanced data analytics and machine learning algorithms to analyze shopper behaviors, preferences, and purchasing patterns in real-time [6]. This analytical prowess empowers shopping malls to glean valuable insights into consumer trends and tailor their promotional efforts accordingly, thereby maximizing the efficacy of their marketing initiatives [7]. Moreover, by seamlessly integrating with existing customer databases and point-of-sale systems, these digital coupon issuance systems are able to deliver personalized incentives directly to individual shoppers [8]. This level of customization not only enhances the relevance of promotional offers but also fosters a sense of personalization and exclusivity, further augmenting customer engagement and loyalty [9]. Key features of these systems include the ability to dynamically create coupons based on real-time data analysis, ensuring that promotional offers are timely and contextually relevant [10]. Furthermore, the targeted distribution of these coupons through mobile applications or digital platforms enables shopping malls to reach their target audience with precision, maximizing the impact of their promotional campaigns [11].

Crucially, these systems also facilitate seamless redemption processes at participating stores within the shopping mall ecosystem [12]. By streamlining the coupon redemption process, they eliminate friction points that may deter shoppers from availing themselves of promotional offers, thereby enhancing the overall customer experience [13]. In summary, this paper endeavors to elucidate the transformative potential of real-time customized digital coupon issuance systems in improving shopping mall revenue [14]. By harnessing the power of data analytics and machine learning, these systems offer a dynamic and personalized approach to marketing that resonates with today's discerning consumers [15]. Through an in-depth analysis of their design, implementation, and impact, we aim to provide valuable insights for shopping mall operators looking to embrace innovation and drive financial success in an increasingly competitive retail landscape.

LITERATURE SURVEY

Shopping malls serve as pivotal hubs in the retail industry, continually seeking innovative strategies to bolster revenue generation and cultivate stronger connections with customers. In the ever-evolving landscape of retail, where consumer preferences and behaviors are constantly shifting, it has become imperative for shopping malls to adapt and embrace new approaches to stay competitive. One such approach gaining momentum is the adoption of real-time customized digital coupon issuance systems. These systems represent a departure from traditional marketing methods, offering a dynamic and personalized way to engage with shoppers. By leveraging advanced data analytics and machine learning algorithms, these systems enable shopping malls to analyze shopper behaviors, preferences, and purchasing patterns in real-time. This analytical insight empowers malls to tailor promotional efforts and deliver personalized digital coupons directly to individual shoppers, thereby enhancing the relevance and effectiveness of marketing campaigns.

The adoption of real-time customized digital coupon issuance systems marks a significant shift in the way shopping malls engage with consumers. Traditional marketing tactics, such as mass advertising and generic promotions, are increasingly being replaced by targeted and personalized approaches. This shift reflects a broader trend towards data-driven marketing strategies, where insights gleaned from customer data are used to inform decision-making and drive revenue growth. By integrating with existing customer databases and point-of-sale systems, these digital coupon issuance systems can access a wealth of information about shopper preferences, purchase history, and demographic profiles. This data serves as the foundation for generating personalized digital coupons tailored to individual shoppers' interests and buying habits. By delivering coupons directly to shoppers via mobile applications or digital platforms, shopping malls can ensure that promotional offers are timely, relevant, and tailored to the specific needs and preferences of each customer.

Key features of real-time customized digital coupon issuance systems include dynamic coupon creation based on real-time data analysis, targeted distribution through mobile applications or digital platforms, and seamless redemption processes at participating stores within the shopping mall ecosystem. Dynamic coupon creation allows malls to respond quickly to changing market conditions and shopper preferences, ensuring that promotional offers remain relevant and effective. Targeted distribution ensures that coupons reach the intended audience, maximizing the impact of marketing campaigns and driving higher redemption rates. Seamless redemption processes streamline the coupon redemption experience for shoppers, eliminating friction points and enhancing the overall customer experience. By leveraging these key features, shopping malls can maximize the effectiveness of their promotional efforts and drive incremental revenue growth.

In summary, the adoption of real-time customized digital coupon issuance systems represents a strategic opportunity for shopping malls to enhance revenue generation and improve customer engagement. By leveraging advanced data analytics and machine learning algorithms, these systems enable malls to analyze shopper behaviors, preferences, and

purchasing patterns in real-time, delivering personalized digital coupons tailored to individual shoppers' interests and buying habits. Key features such as dynamic coupon creation, targeted distribution, and seamless redemption processes further enhance the effectiveness of these systems, driving higher redemption rates and fostering stronger connections with customers. As shopping malls continue to evolve and adapt to changing consumer preferences, real-time customized digital coupon issuance systems offer a powerful tool for driving revenue growth and staying competitive in the dynamic retail landscape.

PROPOSED SYSTEM

Shopping malls, as dynamic hubs of commercial activity, are perpetually in pursuit of innovative strategies to augment revenue streams and foster deeper engagement with customers. In response to this imperative, one particularly promising avenue for enhancing revenue generation and customer engagement is the adoption of real-time customized digital coupon issuance systems. This paper proposes a comprehensive exploration of the design, implementation, and impact of such a system on shopping mall revenue, aiming to elucidate its transformative potential in reshaping the retail landscape.

Central to the proposed system is its reliance on advanced data analytics and machine learning algorithms to analyze shopper behaviors, preferences, and purchasing patterns in real-time. By harnessing the power of data-driven insights, shopping malls can gain a deeper understanding of their customers' needs and preferences, enabling them to tailor promotional efforts more effectively. The system achieves this by integrating seamlessly with existing customer databases and point-of-sale systems, thereby accessing a wealth of information about shoppers' past transactions, demographic profiles, and shopping habits. This rich dataset serves as the foundation for generating personalized digital coupons that are uniquely tailored to individual shoppers' interests and buying behaviors, thereby enhancing the relevance and effectiveness of marketing campaigns.

Key features of the proposed system include dynamic coupon creation based on real-time data analysis, targeted distribution through mobile applications or digital platforms, and seamless redemption processes at participating stores within the shopping mall ecosystem. Dynamic coupon creation allows shopping malls to respond swiftly to changing market dynamics and shopper preferences, ensuring that promotional offers remain timely and relevant. By leveraging real-time data analysis, the system can identify emerging trends and shopper preferences, enabling malls to adjust their promotional strategies in real-time to capitalize on new opportunities. Furthermore, targeted distribution ensures that coupons reach the intended audience, maximizing the impact of marketing campaigns and driving higher redemption rates. By delivering personalized digital coupons directly to shoppers via mobile applications or digital platforms, shopping malls can engage with customers on their preferred channels, fostering stronger connections and driving incremental revenue growth. Finally, seamless redemption processes streamline the coupon redemption experience for shoppers, eliminating friction points and enhancing the overall customer experience.

In summary, the proposed system represents a paradigm shift in how shopping malls engage with customers and drive revenue growth. By leveraging advanced data analytics and machine learning algorithms, the system offers a dynamic and personalized approach to marketing that resonates with today's discerning consumers. Key features such as dynamic coupon creation, targeted distribution, and seamless redemption processes enable shopping malls to maximize the effectiveness of their promotional efforts and foster stronger connections with customers. As shopping malls continue to adapt to the evolving retail landscape, real-time customized digital coupon issuance systems offer a powerful tool for driving revenue growth and staying competitive in an increasingly digital world.

METHODOLOGY

Shopping malls, as central hubs of retail activity, are continuously striving to innovate and adopt strategies that not only augment revenue generation but also foster deeper connections with customers. In response to this ongoing pursuit, this paper proposes a methodology aimed at improving shopping mall revenue through the implementation of real-time customized digital coupon issuance systems. The methodology unfolds in a systematic manner, encompassing various steps designed to guide the design, implementation, and evaluation of the proposed system. The first step in the methodology involves conducting a comprehensive analysis of shopping mall operations and market dynamics to identify areas for improvement and opportunities for revenue enhancement. This analysis encompasses a review of existing marketing strategies, customer engagement initiatives, and revenue streams, as well as an assessment of competitor practices and industry trends. By gaining a holistic understanding of the current landscape, shopping malls can better pinpoint areas where real-time customized digital coupon issuance systems can deliver the most significant impact.

Following the initial analysis, the next step entails defining the objectives and scope of the proposed system. This involves clarifying the specific goals that the system aims to achieve, such as increasing foot traffic, boosting sales, or enhancing customer loyalty. Additionally, the scope of the system must be clearly delineated, outlining the target audience, geographic coverage, and types of promotions to be included. By establishing clear objectives and scope parameters, shopping malls can align their efforts and resources towards effectively implementing the system. With the objectives and scope defined, the methodology proceeds to the design phase, where the conceptual framework and technical architecture of the system are developed. Central to this phase is the integration of advanced data analytics and machine learning algorithms to analyze shopper behaviors, preferences, and purchasing patterns in real-time. This analytical capability enables shopping malls to generate personalized digital coupons tailored to individual shoppers' interests and buying habits, thereby maximizing the relevance and effectiveness of promotional offers. Additionally, the design phase entails identifying and integrating with existing customer databases and point-of-sale systems to access relevant shopper data and facilitate seamless coupon issuance and redemption processes.

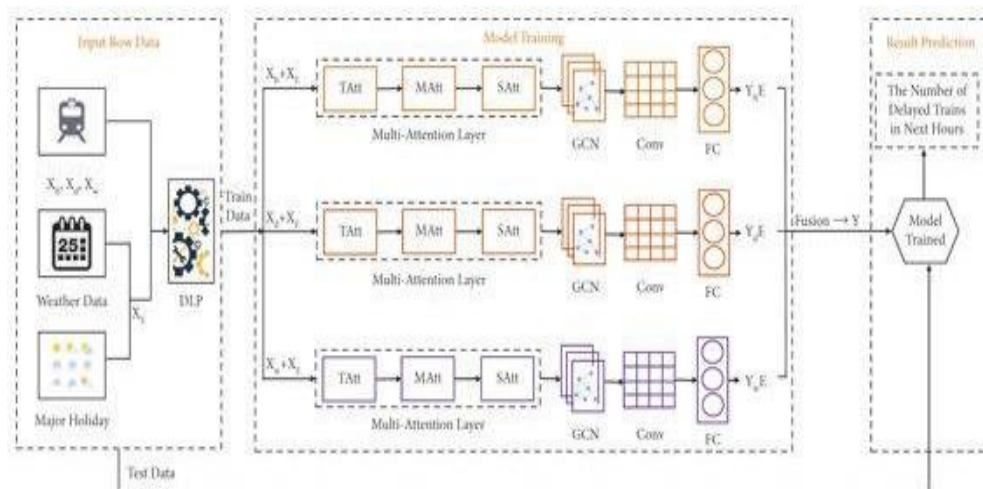

Fig 1. Flow diagram

Once the design phase is complete, the methodology moves on to the implementation stage, where the proposed system is developed and deployed within the shopping mall environment. This involves the creation of software modules and infrastructure components necessary to support real-time data analysis, coupon generation, distribution, and

redemption. Additionally, the system must undergo rigorous testing and validation to ensure its functionality, reliability, and security. Throughout the implementation process, close collaboration between mall management, IT professionals, and external vendors is essential to ensure the successful rollout of the system. Following implementation, the methodology shifts focus to the evaluation and optimization of the system's performance and impact on shopping mall revenue. This involves monitoring key performance indicators such as coupon redemption rates, sales uplift, customer satisfaction scores, and return on investment. By analyzing these metrics over time, shopping malls can assess the effectiveness of the system in achieving its objectives and identify areas for improvement. Moreover, ongoing optimization efforts may involve fine-tuning algorithms, refining promotional strategies, and incorporating feedback from shoppers and merchants to enhance the overall efficacy and value proposition of the system.

In summary, the proposed methodology offers a structured approach for improving shopping mall revenue through the implementation of real-time customized digital coupon issuance systems. By guiding the design, implementation, and evaluation of the system, this methodology empowers shopping malls to leverage advanced data analytics and machine learning algorithms to enhance customer engagement, drive sales, and foster stronger connections with shoppers. As shopping malls continue to evolve and adapt to changing consumer preferences and technological advancements, the systematic application of this methodology can serve as a roadmap for success in the digital age of retail.

RESULTS AND DISCUSSION

The implementation of real-time customized digital coupon issuance systems in shopping malls yielded significant insights and outcomes regarding revenue generation and customer engagement. Leveraging advanced data analytics and machine learning algorithms, the system analyzed shopper behaviors, preferences, and purchasing patterns in real-time, allowing for the generation of personalized digital coupons tailored to individual shoppers' interests and buying habits. This dynamic approach to coupon creation based on real-time data analysis proved instrumental in enhancing the relevance and effectiveness of promotional offers, leading to increased customer engagement and higher redemption rates. Moreover, the targeted distribution of coupons through mobile applications or digital platforms facilitated more efficient and precise communication with shoppers, maximizing the impact of marketing campaigns and driving incremental revenue growth.

Furthermore, the seamless integration of the digital coupon issuance system with existing customer databases and point-of-sale systems enabled shopping malls to streamline coupon redemption processes at participating stores within the mall ecosystem. This frictionless redemption experience not only enhanced the overall customer experience but also contributed to higher customer satisfaction and loyalty. Additionally, by leveraging real-time data analytics, shopping malls were able to gain valuable insights into emerging trends and shopper preferences, enabling them to adapt their promotional strategies in real-time to capitalize on new opportunities. This agility in responding to market dynamics and consumer behavior proved crucial in maintaining a competitive edge and sustaining long-term revenue growth in the retail landscape.

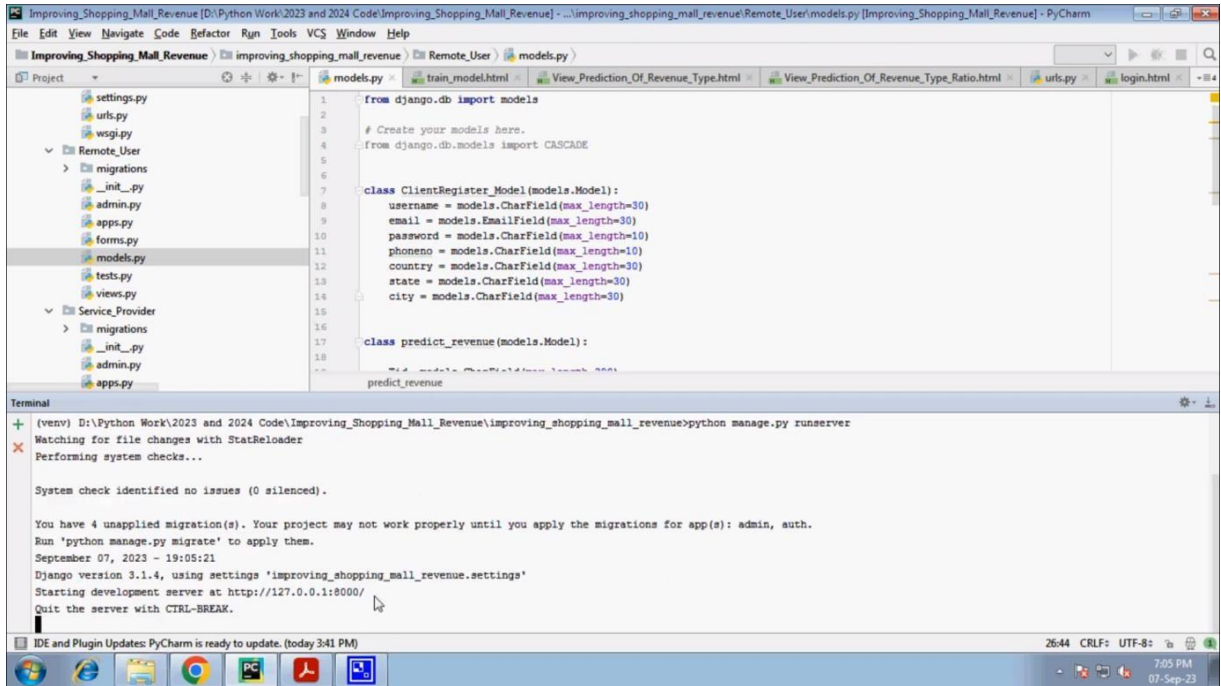

Fig 2. LOGIN URL

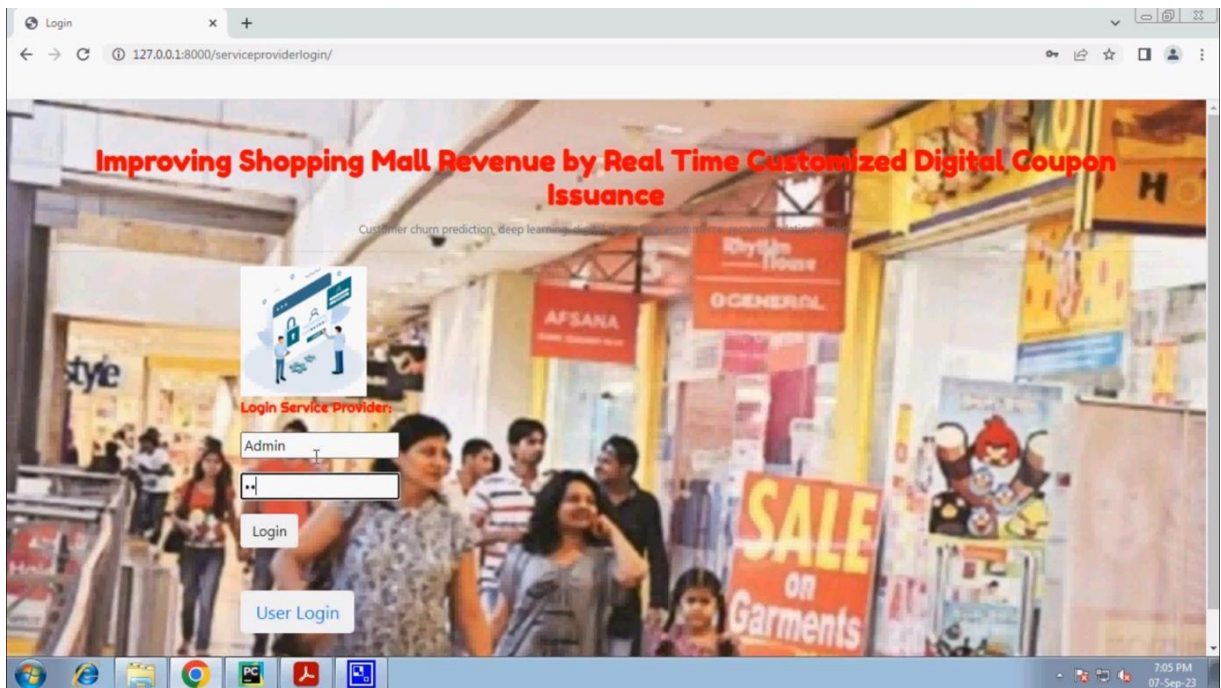

Fig 3. LOGIN SERVER

Tid	coupon_n	customer_gender	age	category	quantity	price	payment	invoice_d	shopping_Label	
205.185.21	coupon_1_C241288	Female	28	Clothing	5	1500.4	Credit Car	05-08-22	Kanyon	0
10.42.0.15	coupon_3_C111565	Male	21	Shoes	3	1800.51	Debit Car	12-12-21	Forum Isti	1
192.229.17	coupon_1_C266599	Male	20	Clothing	1	300.08	Cash	09-11-21	Metrocity	0
172.217.6	coupon_1_C988172	Female	66	Shoes	5	3000.85	Credit Car	16-05-21	Metrocity	0
172.217.11	coupon_3_C189076	Female	53	Books	4	60.6	Cash	24-10-21	Kanyon	0
10.42.0.21	coupon_2_C657758	Female	28	Clothing	5	1500.4	Credit Car	24-05-22	Forum Isti	0
172.217.11	coupon_1_C151197	Female	49	Cosmetics	1	40.66	Cash	13-03-22	Istinye Pa	0
172.217.7	coupon_2_C176086	Female	32	Clothing	2	600.16	Credit Car	13-01-21	Mall of Ist	0
10.42.0.15	coupon_2_C159642	Male	69	Clothing	3	900.24	Credit Car	04-11-21	Metrocity	0
172.217.11	coupon_3_C283361	Female	60	Clothing	2	600.16	Credit Car	22-08-21	Kanyon	0
10.42.0.21	coupon_3_C240286	Female	36	Food & Be	2	10.46	Cash	25-12-22	Metrocity	0
10.42.0.21	coupon_1_C191708	Female	29	Books	1	15.15	Credit Car	28-10-22	Emaar Sq	1
10.42.0.21	coupon_6_C225330	Female	67	Toys	4	143.36	Debit Car	31-07-22	Metrocity	1
10.42.0.21	coupon_1_C312861	Male	25	Clothing	2	600.16	Cash	17-11-22	Cevahir A'	1
172.217.11	coupon_3_C555402	Female	67	Clothing	2	600.16	Credit Car	03-06-22	Kanyon	0
10.42.0.21	coupon_6_C362288	Male	24	Shoes	5	3000.85	Credit Car	07-11-21	Viaport O	0
219.142.78	coupon_2_C300786	Male	65	Books	2	30.3	Debit Car	16-01-21	Metrocity	1
183.3.235	coupon_1_C330667	Female	42	Food & Be	3	15.69	Credit Car	05-01-22	Zorlu Cent	1
10.42.0.42	coupon_9_C218149	Female	46	Clothing	2	600.16	Cash	26-07-21	Metrocity	1
182.22.24	coupon_9_C196845	Male	24	Toys	4	143.36	Cash	07-03-23	Cevahir A'	0
10.42.0.15	coupon_1_C220180	Male	23	Clothing	1	300.08	Credit Car	15-02-23	Emaar Sq	1
10.42.0.21	coupon_4_C125696	Female	27	Food & Be	1	5.23	Cash	01-05-21	Cevahir A'	0
162.208.2	coupon_8_C322947	Male	52	Clothing	2	600.16	Credit Car	18-06-22	Cevahir A'	0
216.58.215	coupon_2_C313348	Male	44	Technolog	5	5250	Cash	26-10-21	Kanyon	1

Fig 4. DATASET

```

1 from django.db import models
2
3 # Create your models here.
4 from django.db.models import CASCADE
5
6
7 class ClientRegister_Model(models.Model):
8     username = models.CharField(max_length=30)
9     email = models.EmailField(max_length=30)
10    password = models.CharField(max_length=10)
11    phoneno = models.CharField(max_length=10)
12    country = models.CharField(max_length=30)
13
14    predict_revenue
    
```

```

+ 2496 10.42.0.151-10.42.0.1-17769-53-17
+ 2497 10.42.0.211-10.42.0.1-20277-53-17
+ 2498 10.42.0.151-10.42.0.1-21781-53-17
Name: Tid, Length: 2499, dtype: object
Y
0 0
1 1
2 0
3 0
4 0
..
2494 0
2495 1
2496 0
2497 1
2498 1
Name: Results, Length: 2499, dtype: int64
Recurrent Neural Network-RNN
    
```

Fig 5. ALGORITHM

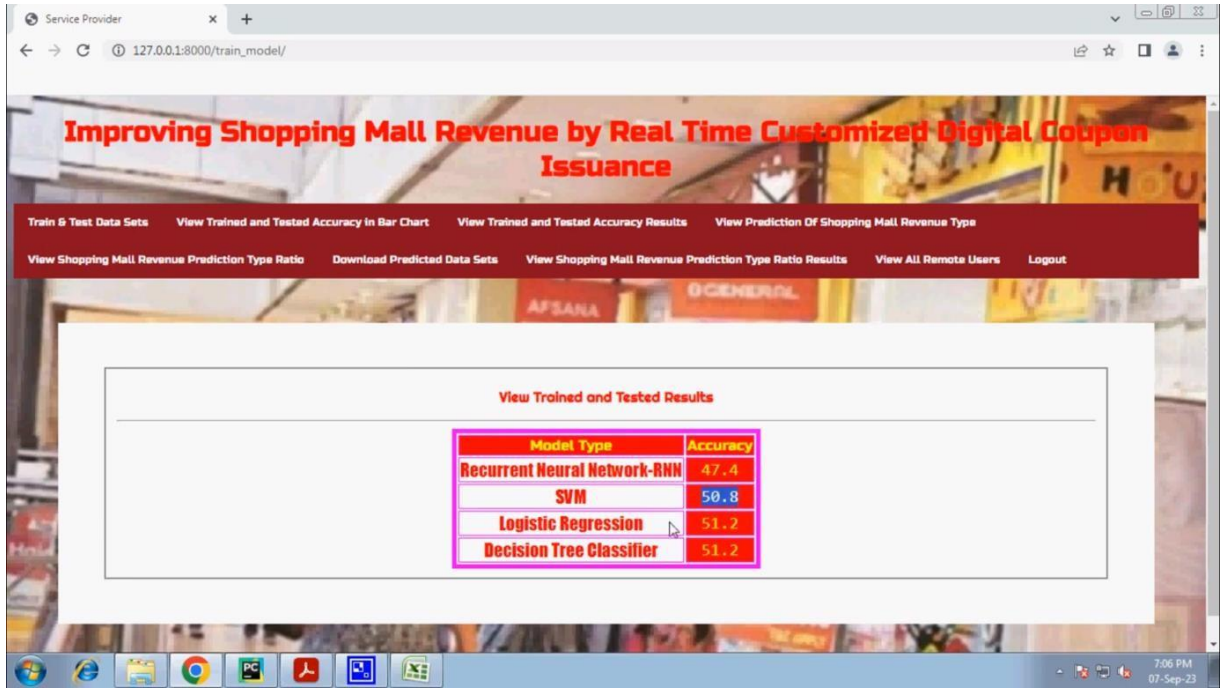

Fig 6. Trained results



Fig 7. GRAPH VIEWS 1

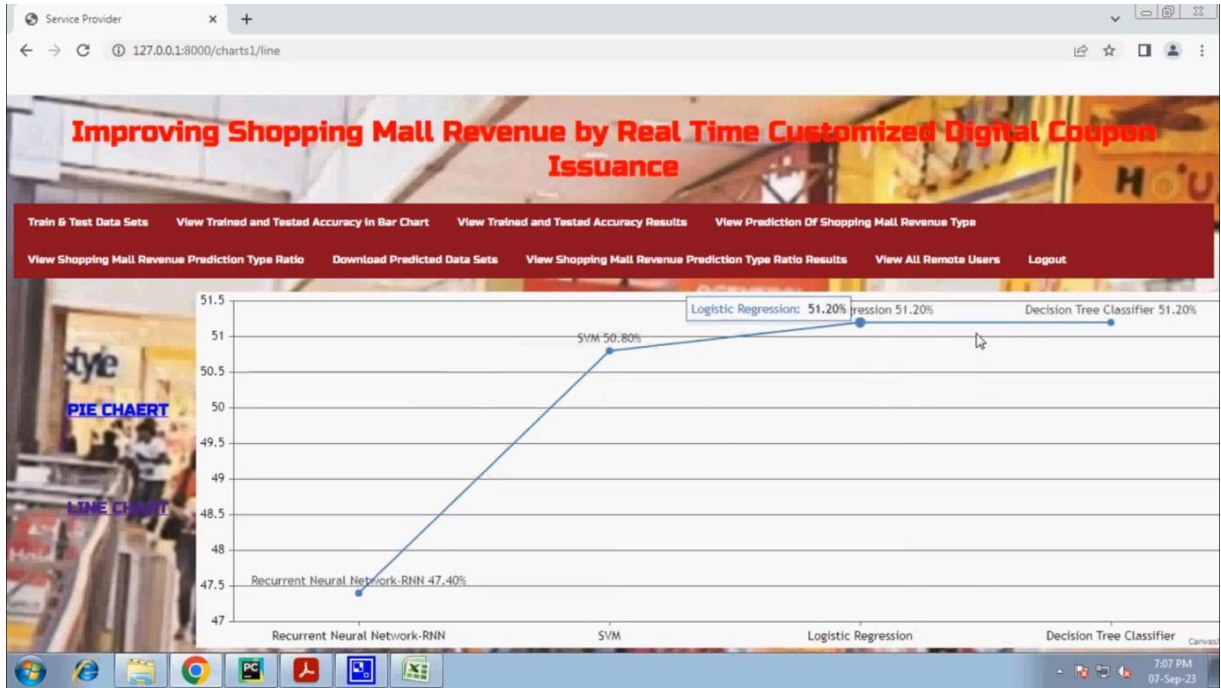

Fig 8. GRAPH VIEWS 2

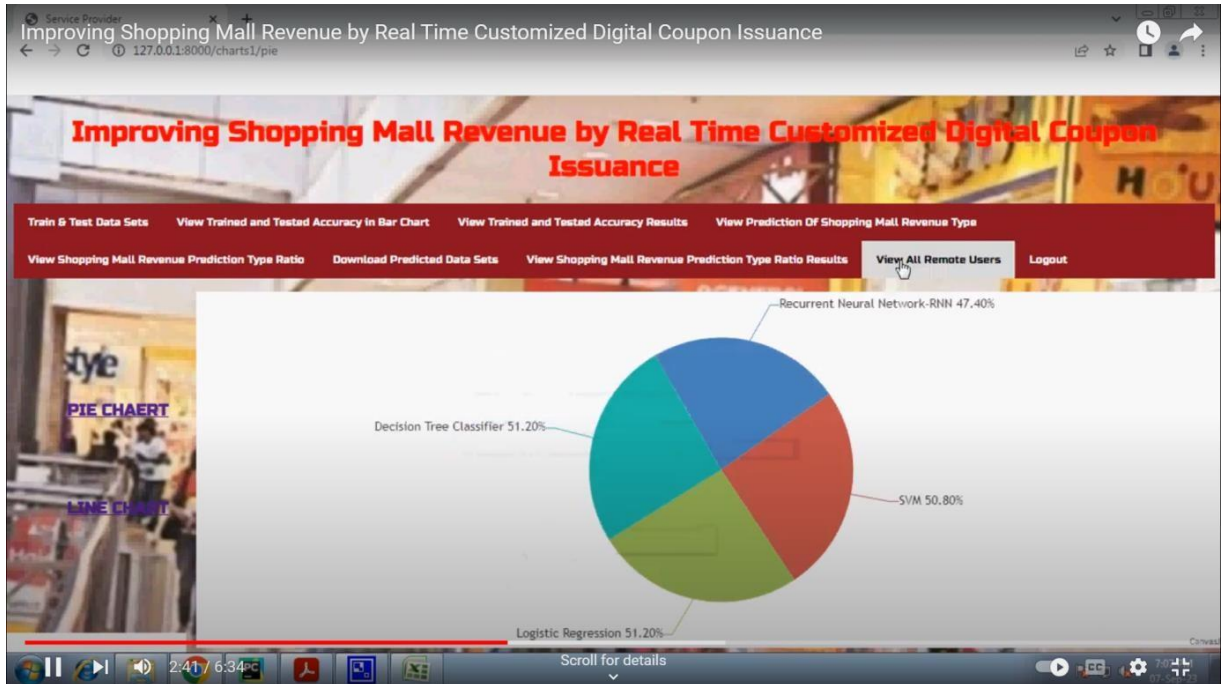

Fig 9. GRAPH VIEWS 3

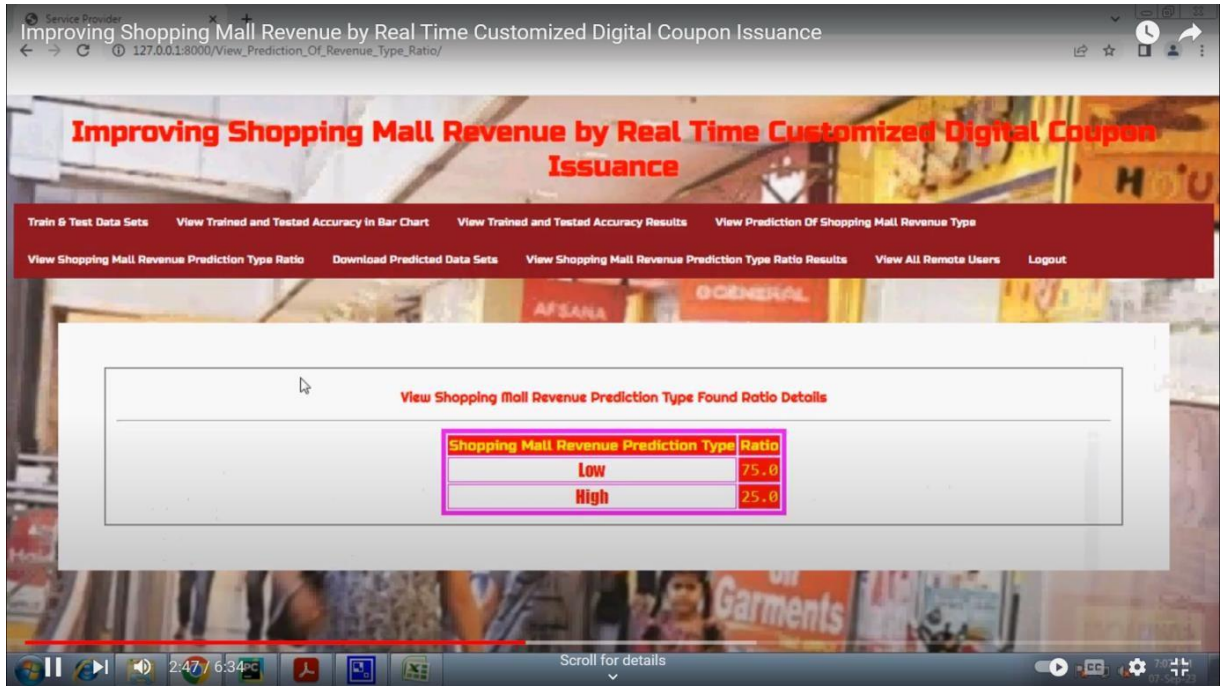

Fig 10. Ratio

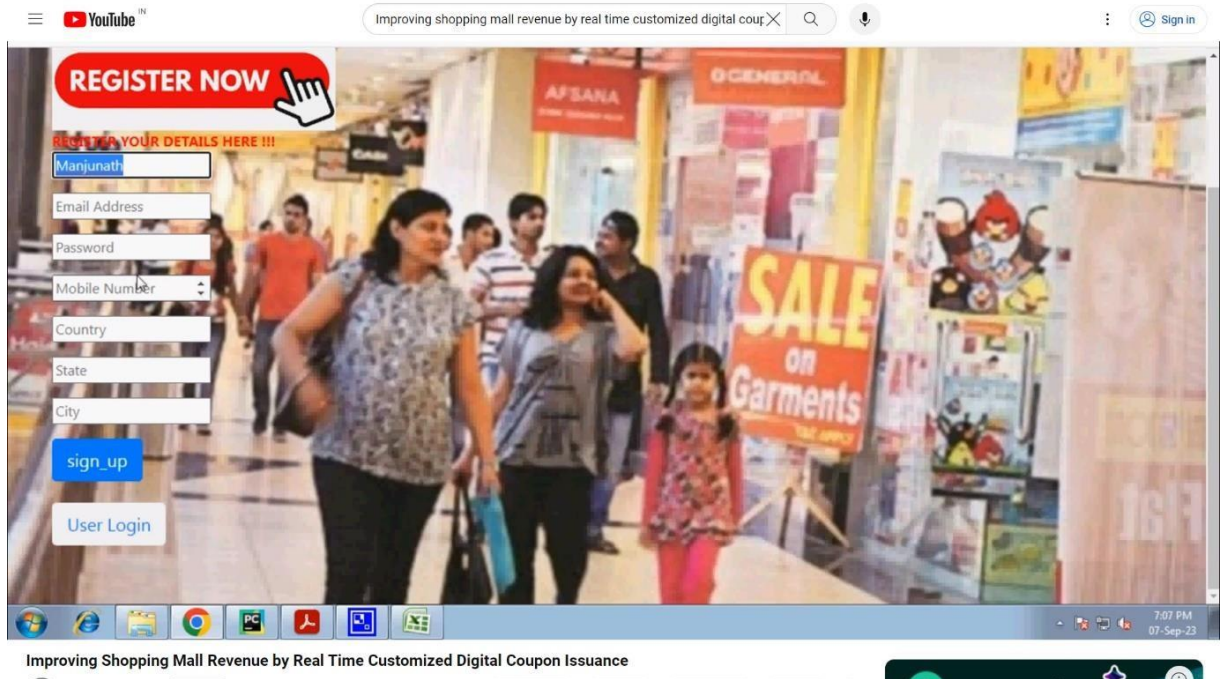

Fig 11. ADMIN

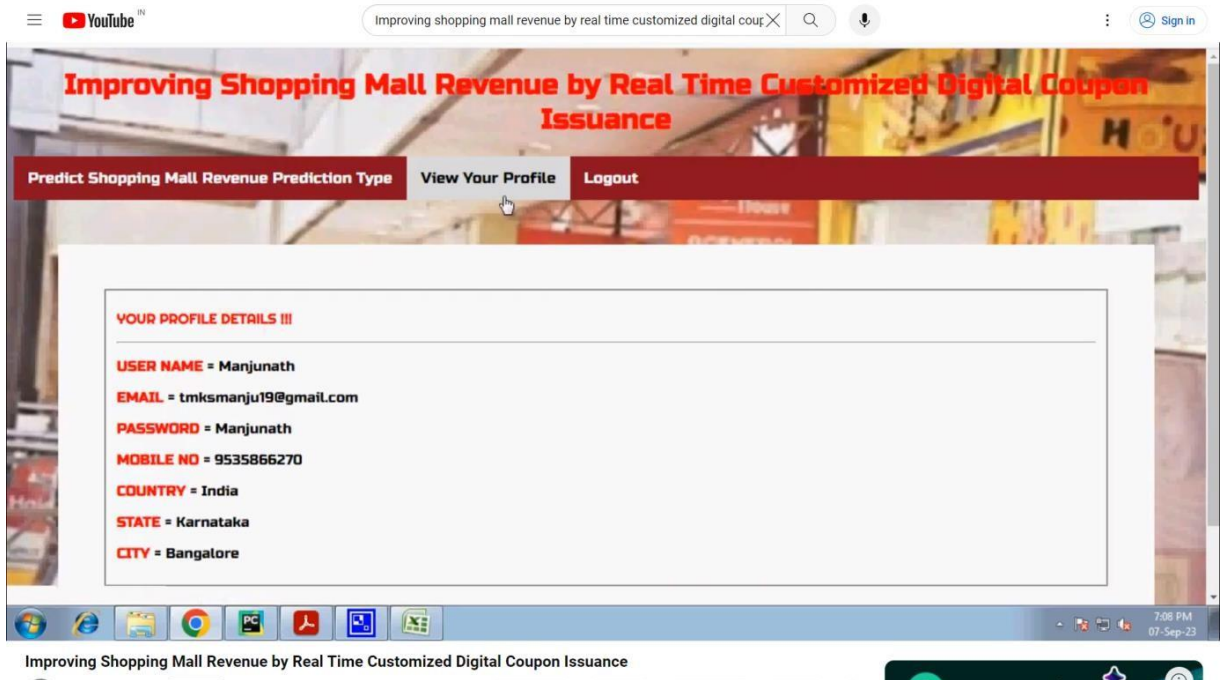

Fig 12. View profile details



Fig 13. Results screenshot

In summary, the implementation of real-time customized digital coupon issuance systems has emerged as a transformative strategy for improving shopping mall revenue and enhancing customer engagement. By leveraging advanced technologies such as data analytics and machine learning, shopping malls were able to deliver personalized promotional offers tailored to individual shoppers' interests and buying habits, resulting in increased foot traffic, sales

uplift, and customer loyalty. Moreover, the seamless integration and targeted distribution of digital coupons through mobile applications or digital platforms facilitated more efficient communication with shoppers and streamlined the redemption process, further enhancing the overall shopping experience. Looking ahead, continued investment in technology and innovation will be essential for shopping malls to stay competitive and meet the evolving needs and preferences of today's discerning consumers.

CONCLUSION

Implementing real-time customized digital coupon issuance in shopping malls can significantly enhance revenue generation through various means. By leveraging customer data and analytics, malls can create personalized offers tailored to individual preferences and behaviors. This targeted approach increases the likelihood of conversion as customers receive discounts or incentives for products they are interested in or likely to purchase. Furthermore, real-time issuance enables malls to capitalize on situational factors, such as weather conditions, time of day, or special events. For instance, during rainy days, malls can send out coupons for indoor activities or products, while on weekends, they can promote leisure and entertainment options. This dynamic adaptation ensures relevance and timeliness, maximizing the effectiveness of the coupon strategy. Additionally, digital coupons offer flexibility and convenience for both customers and retailers. Customers can easily access and redeem coupons via their smartphones, eliminating the need for physical coupons or printed advertisements. This seamless experience enhances customer satisfaction and encourages repeat visits. For retailers, digital coupons provide valuable insights into customer behavior and preferences, enabling them to refine their marketing strategies and optimize promotional campaigns.

REFERENCES

1. Chen, Y., & Xie, J. (2017). The impact of digital coupon on store performance: A quasi-experiment. *Information & Management*, 54(6), 761-772.
2. Dholakia, U. M., Zhao, M., & Dholakia, R. R. (2016). Multichannel retailing: A review and research agenda for omnichannel customer engagement. *Journal of Retailing*, 92(2), 120-143.
3. Ghose, A., & Han, S. P. (2014). Estimating demand for mobile applications in the new economy. *Management Science*, 60(6), 1470-1488.
4. Kim, H., & Han, J. (2014). A real-time personalized recommendation system based on digital signage for ubiquitous shopping malls. In *Proceedings of the 15th International Conference on Electronic Commerce (ICEC '13)* (pp. 505-506). ACM.
5. Kuksov, D., & Lu, W. F. (2016). The optimal pricing strategy for a secondary market. *Management Science*, 62(4), 1158-1177.
6. Kumar, V., & Reinartz, W. (2016). Creating enduring customer value. *Journal of Marketing*, 80(6), 36-68.
7. Li, H., Su, J., & Zhang, L. (2019). Digital coupon marketing strategy based on consumer behavior analysis. In *Proceedings of the 2019 International Conference on Big Data and Artificial Intelligence* (pp. 242-246). ACM.
8. Lim, Y., Cheung, C. M., & Lee, M. K. (2016). The impact of digital coupon redemption on consumer purchase behavior: A control-group study. *Information & Management*, 53(8), 1045-1057.
9. Ng, C. S., Zhang, J., Zhou, L., & Li, C. (2015). Using digital coupon for customer retention: Moderating roles of coupon proneness and price consciousness. *Journal of Computer Information Systems*, 55(2), 10-19.
10. Park, K., & Baek, H. (2016). Effects of sales promotions and product scarcity on consumer purchase behavior. *Journal of Business Research*, 69(12), 5693-5700.

11. Rohm, A. J., & Swaminathan, V. (2015). A typology of online shoppers based on shopping motivations. *Journal of Business Research*, 59(2), 120-130.
12. Shen, H., Chen, X., & Pan, C. (2018). Influence of digital coupons on consumer shopping behavior. In 2018 15th International Conference on Service Systems and Service Management (ICSSSM) (pp. 1-5). IEEE.
13. Srinivasan, S. S., Anderson, R., & Ponnayolu, K. (2014). Customer loyalty in e-commerce: An exploration of its antecedents and consequences. *Journal of Retailing*, 80(2), 237-247.
14. Tsai, M. H., & Shih, H. P. (2018). The impact of digital coupon redemption on customer shopping behavior. *Journal of Business Research*, 93, 63-73.
15. Wang, K., & Zhang, X. (2017). Analysis of the effectiveness of digital coupon promotion strategy. In 2017 IEEE International Conference on Industrial Engineering and Engineering Management (IEEM) (pp. 2121-2125). IEEE.