

**International Journal of
Engineering Research and Science & Technology**



ISSN : 2319-5991

www.ijerst.com

Email: editor@ijerst.com or editor.ijerst@gmail.com

Upgrading the 31-Level Distribution Network Through Integration of Advanced Lower DC Voltage Sources

Seelam Sandhya¹, Nageswara Rao Sikha¹, Kolla Lahari², Pedamallu Ooha Madhuri², Telaprolu Venkata Sai Prasanna², Pasupuleti Durga Sri Lakshmi²

¹Assistant Professor, Department of Electrical and Electronics Engineering, SRK Institute of Technology-Enikepadu, Vijayawada-521108, Andhra Pradesh, India

²Department of Electrical and Electronics Engineering, SRK Institute of Technology-Enikepadu, Vijayawada-521108, Andhra Pradesh, India

ABSTRACT:

In this research, we propose a novel topology for a 31-level asymmetrical multilevel inverter optimized for single-phase operation, boasting a streamlined design with fewer components compared to existing configurations. Leveraging an H-bridge configuration in conjunction with asymmetric DC sources, this innovative topology enables the generation of an output voltage with up to 31 distinct levels. Initially conceived as an extension of the fundamental 13-level multilevel inverter (MLI) architecture, our study delves deeper into refining the topology to accommodate 31 levels, catering to the burgeoning demand for renewable energy applications.

Through meticulous design refinement, our approach significantly reduces system size, cost, and the number of individual components, thereby enhancing overall system efficiency and affordability. Despite the numerous advantages offered by MLIs, reliability remains a persistent challenge due to the additional components required to mitigate total harmonic distortion (THD). Addressing this concern, our research endeavors to strike a balance between enhancing reliability and minimizing THD levels, a formidable task that has eluded many researchers.

Key performance metrics including total standing voltage (TSV), cost function (CF), and power loss are comprehensively analyzed for both the foundational 13-level and the advanced 31-level MLIs. Rigorous laboratory testing under diverse dynamic load conditions, encompassing various combinational loads and unexpected load disturbances, validates the efficacy of the proposed MLI architecture.

Comparative analyses against previously published topologies highlight the cost-effectiveness of our proposed MLI, showcasing reduced TSV requirements and component count. Moreover, THD levels achieved comfortably comply with IEEE standards, underscoring the robustness of the architecture.

Theoretical validation through MATLAB/Simulink simulations is seamlessly complemented by empirical testing utilizing a hardware prototype across a spectrum of real-world scenarios, reaffirming the viability and efficacy of our proposed MLI architecture.

Key words: Total harmonic distortion, Total Sequence Voltage, Total Sequence Voltage Calculation, and Cost Function (CF) in Multilevel Inverters (THD).

INTRODUCTION:

Multilevel inverters have a bigger market share because of their high power operating capacity and other benefits such as reduced electromagnetic interference, improved power quality, and lower switching losses [1, 2]. According to certain sources[not in citation given] These MLIs employ a variety of DC sources and power electronic circuits to create a discrete-step output voltage waveform. There is a large selection of power semiconductor switches that may be utilised in this circuit. [3] Boosting the volume may also enhance the quality of the waveform as a whole. [4] Increasing the number of circuit components to improve MLI reliability and efficiency raises circuit costs.

MLIs may be diode clamped, flying capacitor, or cascaded H-bridge (CHB). Depending on the magnitudes of the DC voltages, CHB inverters may be classified as symmetric or asymmetric [6]. There are two major types of MLIs, and they are symmetric and asymmetric, respectively. All of the DC voltage sources in the symmetric multilayer inverter I'm employing are of the same strength. Every CHB type inverter module may either have a positive, negative, or 0 volt output. The module's state determines the output's current condition. The output voltage of a CHB type inverter may be determined by summing the voltages of each module [7], [8]. High-voltage voltage balancing is harder when using an FC or NPC type inverter as opposed to a CHB type inverter [9].

Cascaded multilevel inverters have seen a number of suggested topologies from a variety of control methods in recent years [4, [10]–[13]. Multiple symmetric cascaded multilevel inverter topologies are shown in [3], [14–20]. Benefiting greatly from low DC voltage sources, which is a key factor in deciding an inverter's cost, these topologies have several applications. However, the primary downside of various topologies is the increased need of bidirectional switches in places where a significant number of IGBTs is required. In [21], an asymmetric type inverter is shown as an architecture, where more IGBTs are needed due to the higher number of bidirectional power switches. A revolutionary architecture with a decreased number of switches provided with multiple algorithms in [18] yet numerous voltage sources exist, which is a downside of this topology. Minimizing these difficulties by efficient use of semiconductor devices is possible. Using sources with different magnitudes of dc voltage allows for a reduction in the total number of switches required [3]. Several devices [22], [23] are demonstrated that have an enhanced voltage level with lower power switching. The output of these devices is a DC step and is transformed to AC step using a full-bridge converter. Because the full-bridge converter filters out the higher voltages, its use is restricted to those applications that need the high voltages. Many new topologies are provided to minimise the components count for both single-phase and three-phase system. In [24], we see the three-phase system represented as a collection of three independent phases.

Some multilayer output designs need fewer switches and DC sources [25]. [26]–[29] show topologies for bidirectional current with fewer switches. Antiparallel-coupled bidirectional switches are used. As switches become increasingly modular, cascading sub-units may reduce blocking voltage at each. As output level grows, such topologies need more switches. So, new MLI architectures with fewer components and blocking voltage are needed. Inverter price drops. A packed H-bridge MLI design [30, 31] has been suggested; it connects basic units on both sides of the full-bridge. Topologies are constructed without H-bridge to reduce voltage demand on circuit switches. Many of these topologies need certain items.

Single-phase inverters were originally connected in series to create the multilayer inverter design. A cascaded H-bridge (CHB) inverter [7] is a common name for this setup. By connecting diodes to the neutral point, as in Neutral Point Clamped (NPC) inverters, many levels of output voltage may be generated from a single DC source [8]. A Flying Capacitor (FC) inverter was built by combining multiple capacitors [9]. We often refer to the aforementioned architectures as "Classical Topologies." Figure 1 illustrates the requirement for innovative control procedures for the

reduced device count inverters that have been the focus of much research in recent years. Packed U-Cell (PUC) is a three-output voltage source compatible modular construction. The number of active switches remains constant [10] in this setup..

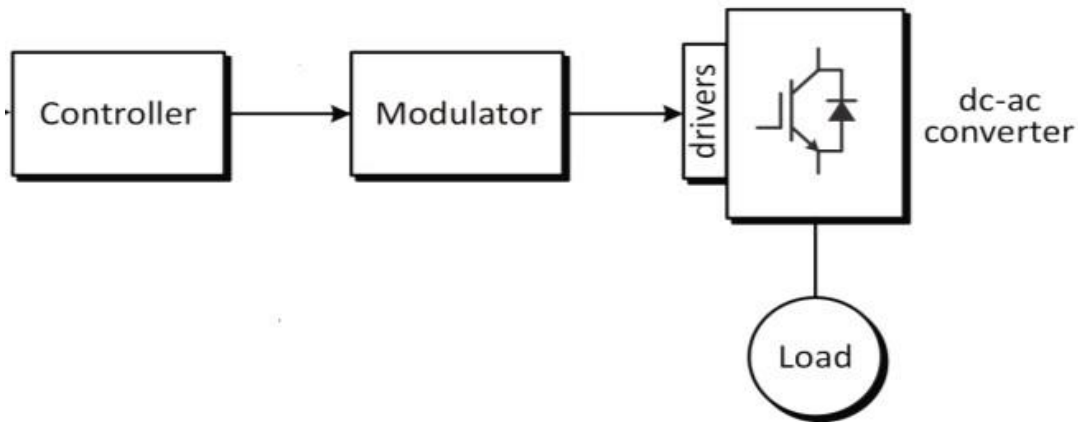

Fig. 1. Open-loop operation of DC/AC converter

MULTILEVEL INVERTER TOPOLOGY

In Fig. 2, we show the block diagram of the circuit that creates the 31-level inverter output, which comprises of the Level Generation Circuit, Polarity Generation Circuit, and Driving Circuit. Asymmetric designs may be able to provide more power than their symmetric counterparts when using the same number of semiconductor devices and voltage sources. The MLI configuration is shown in Figure 3, and it comprises of the Level generating unit in the asymmetric basic circuit and the Polarity generation circuit in the H-bridge inverter. In the circuit that produces polarity, the switches will be subjected to more stress than those producing a constant level.

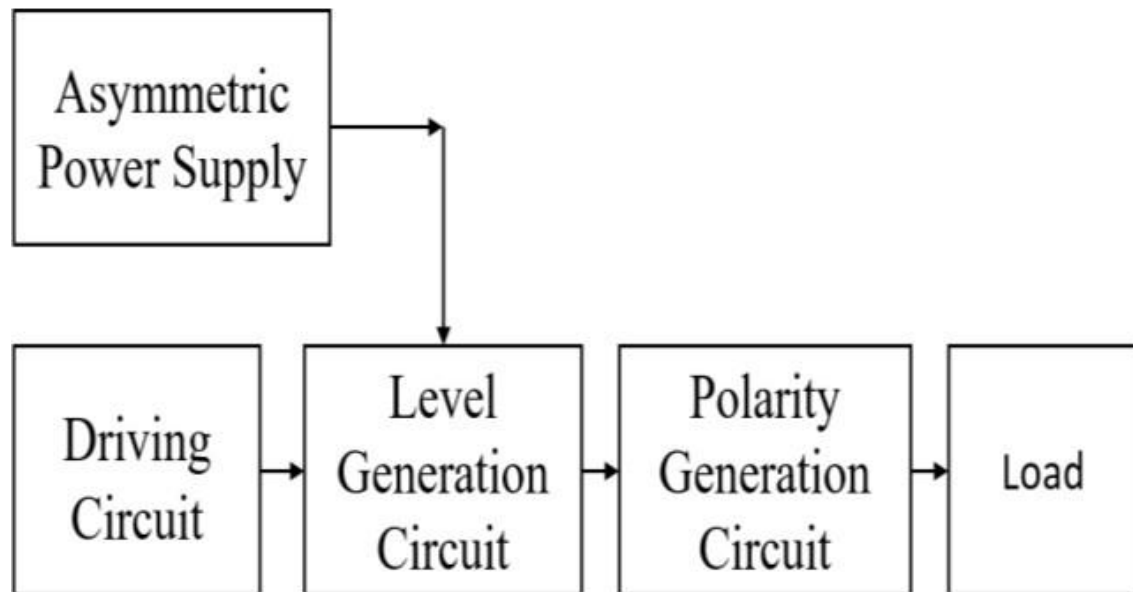

Fig. 2. Control block diagram

Because this design only makes use of unidirectional semiconductor switching components, the total number of MOSFETs and driver circuits remains same. In a multilayer inverter circuit, the current, blocking voltage, and switching frequency all have a connection with one another, which results in switching losses. The current status of each switch that makes up the level producing unit is broken out in Table 1. A total of 15 levels is produced when the outputs of the S1, S2, S3, and S4 level generators as well as those of the T1 and T2 polarity generators are combined. Turning off switches S1, S2, S3, and S4 simultaneously will result in the volume being reduced to zero. When the outputs of the polarity generator (T2 and T3) are combined with the outputs of the level generator (S1, S2, S3, and S4), a negative half cycle will be produced. This negative half cycle is the opposite of the positive half cycle.

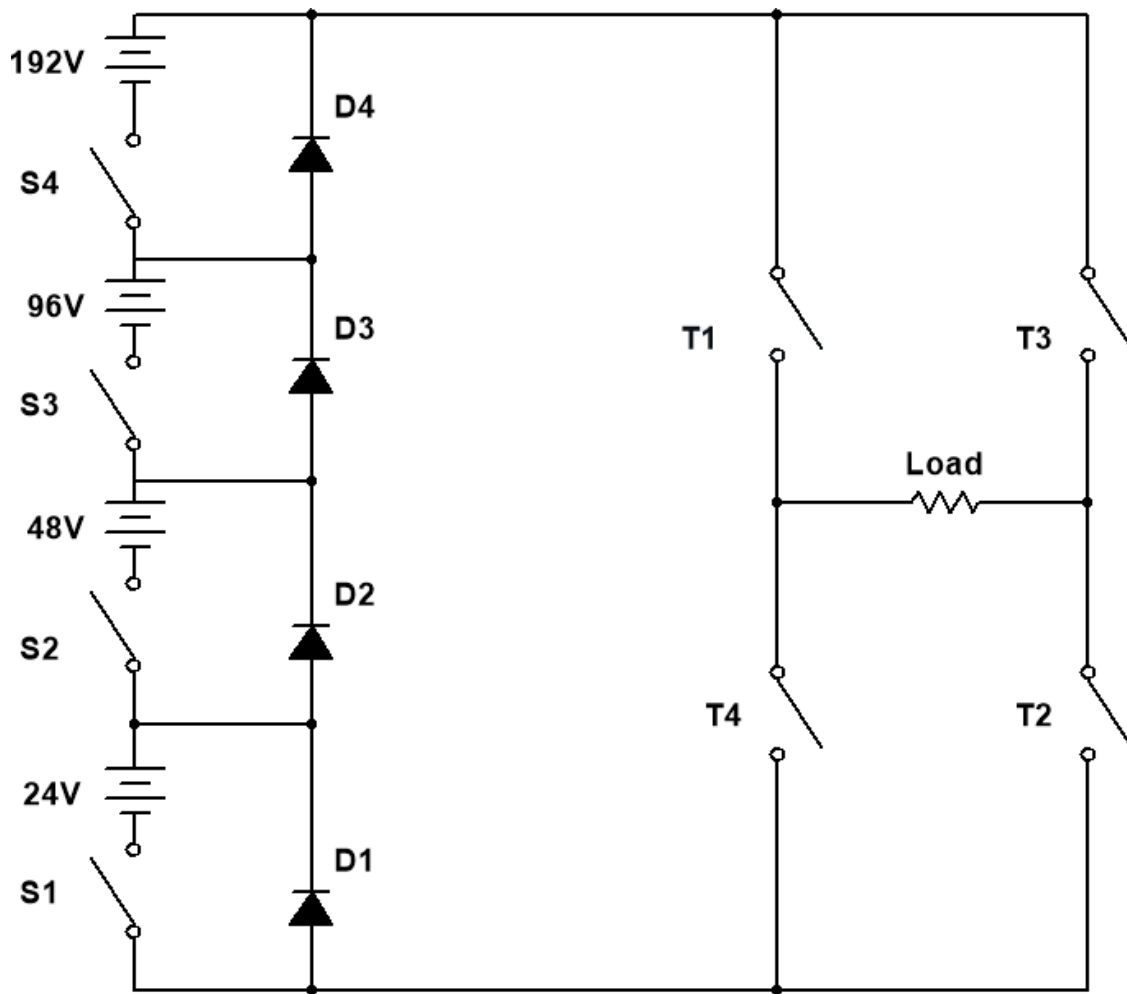

Fig. 3. Circuit Diagram

The third state, for instance, has diodes D3 and D4 forward biased and switches S1 and S2 turned on. $V_o = V_1 + V_2$ is the result we acquire during the positive half cycle. To get the voltage values at the output, this procedure is repeated for each of the other states.

State	Switches States				Output Voltage
	$S4$	$S3$	$S2$	$S1$	
0	0	0	0	0	0
1	0	0	0	1	V_1
2	0	0	1	0	V_2
3	0	0	1	1	$V_1 + V_2$
4	0	1	0	0	V_3
5	0	1	0	1	$V_1 + V_3$
6	0	1	1	0	$V_2 + V_3$
7	0	1	1	1	$V_1 + V_2 + V_3$
8	1	0	0	0	V_4
9	1	0	0	1	$V_1 + V_4$
10	1	0	1	0	$V_2 + V_4$
11	1	0	1	1	$V_1 + V_2 + V_4$
12	1	1	0	0	$V_3 + V_4$
13	1	1	0	1	$V_1 + V_3 + V_4$
14	1	1	1	0	$V_2 + V_3 + V_4$
15	1	1	1	1	$V_1 + V_2 + V_3 + V_4$

The subsequent chapters will cover the planning of this circuit. This circuit is simulated to test the THD and other characteristics.

WORKING:

From this structure, we can deduce that the semiconductor devices utilised in the polarity generator unit have a voltage blocking capacity of V_m . As a result, MOSFETs with higher ratings than the polarity generating unit will be employed in the level generation section [17]. Using a special arrangement, we may acquire new voltage levels by subtracting existing ones in a ternary setup.

Merits of this circuit are:

- Circuit is simple and modular
- Only unidirectional switches are used

- High rated switches can operate at fundamental frequency.

Open-loop control utilises a non-measurement dependent reference [18]. This benchmark has already been calculated (offline) for a specific operating condition. Because of this, the system's dynamic reaction suffers. The inability to use trinary combinations and the need for isolated DC sources are the main drawbacks of this architecture. The total harmonic distortion (THD) [11] is improved as a primary function of multilevel inverters.

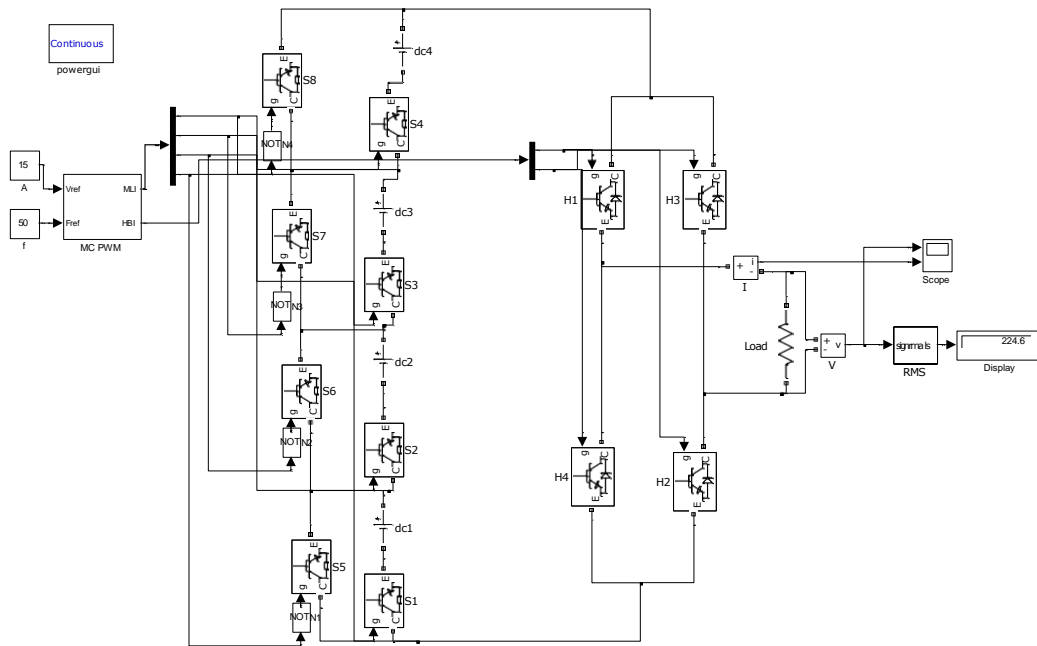

Fig. 4. The 31-level inverter's simulation diagram

Simulation Results

Following is an examination of the outcome of a 31-level inverter with the optimum number of switches. The following are examples of the input voltage sources: In this case, $V_1=24V$, $V_2=48V$, $V_3=96V$, and $V_4=192V$. Voltage output is assumed to be 50Hz. Table 1 displays the switching states and the corresponding magnitudes of the output voltage V_o . The semiconductor switching device, or MOSFET, receives the output from the pulse generator.

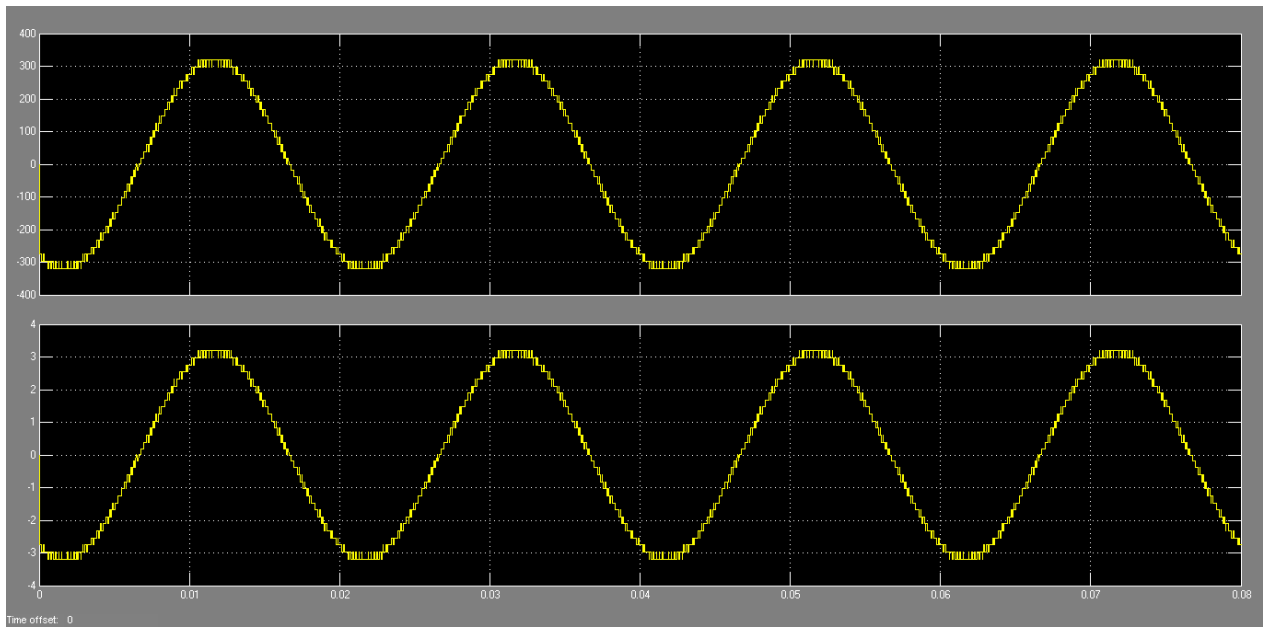

Fig. 5. Waveforms of voltage and current at the output have been modelled.

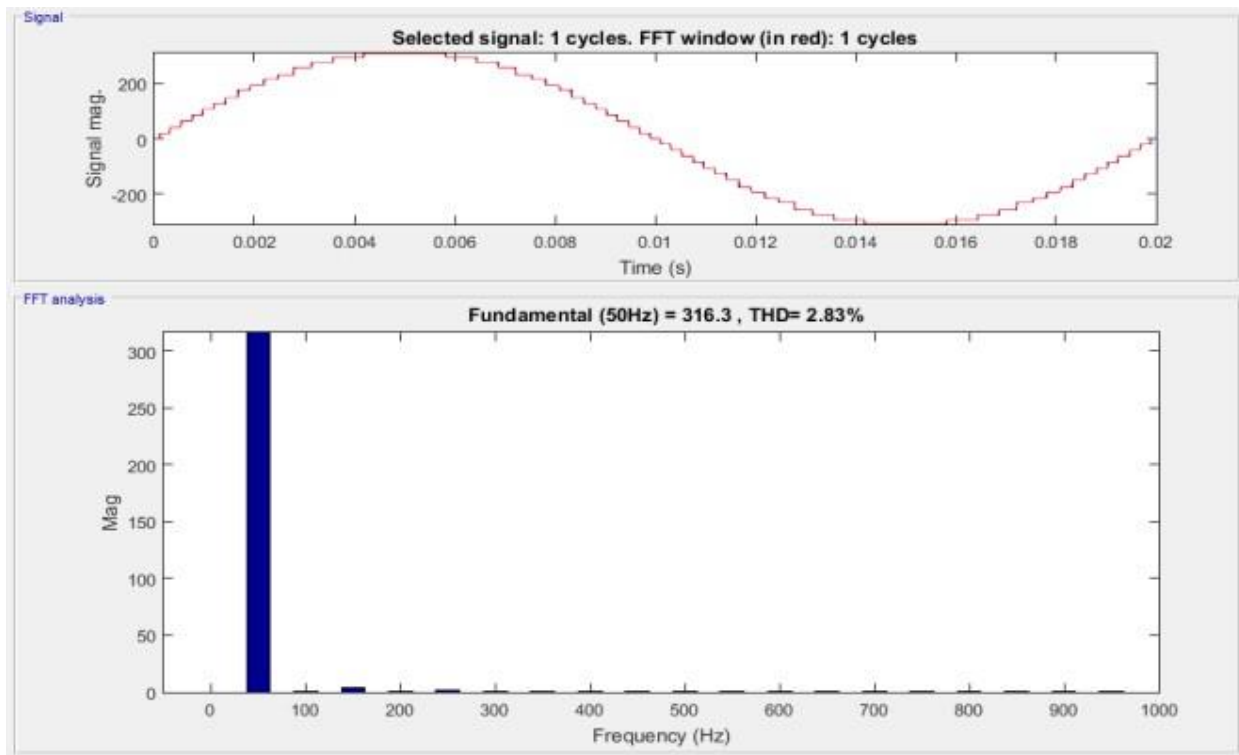

Fig. 6. Harmonic waveform and output voltage waveform simulated

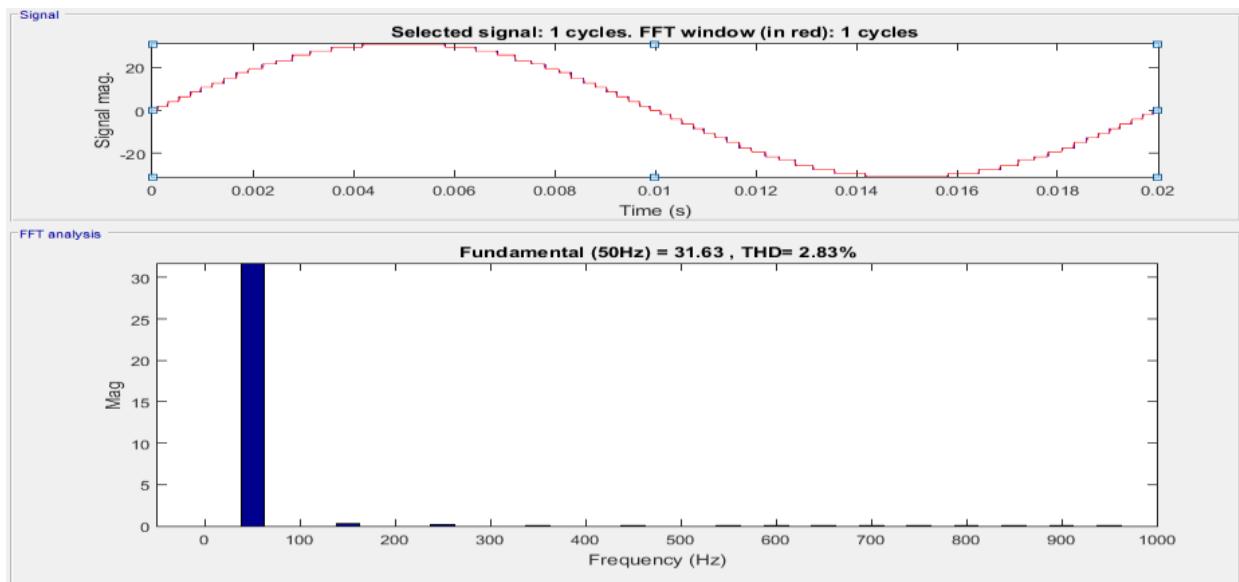

Fig. 7. The waveform and harmonic spectrum of the output current, as simulated.

There is a 1V amplitude to these pulses. The most stressed switch has the slowest operating frequency [19]. The inverter's output voltage and load current both fall within the 2.83% tolerance of the IEEE standard for harmonics (IEEE 519). Figures 6 and 7 illustrate this point.

CONCLUSION:

In this work, we suggest a multilayer inverter architecture that is optimal for medium voltage applications. The fundamental benefit of this layout is its straightforward construction, which makes it possible to minimise both the physical dimensions of the multilayer inverter and the complexity of the driving circuit. In order to simulate, we use the MATLAB/SIMULINK environment. A 31-level output with THD of 2.83% is achieved. In addition, characteristics of this topology at increased output levels may be deduced. The optimal asymmetric topology has been determined after evaluating its pros and cons against those of competing architectures. The MLDCCL asymmetric structure inverter's semiconductor switching devices have lower blocking voltage values compared to those of inverters with other asymmetric topologies. Here we give the simulated outcome for the recommended strategies. The number of MOSFETs required by the proposed inverter architecture has been shown to be reduced. By employing this topology we may equivalently decrease number of gate drivers, thereby lowering the size of the circuit. Energy savings are achieved by not having to use additional passive filters.

REFERENCES:

- [1] L. M. Tolbert, F. Z. Peng, D. J. Adams, J. W. Mckeever, and A. Background, "Multilevel Inverters for Large Automotive Electric Drives," vol. 2, pp. 209–214, 2009.
- [2] E. Villanueva, P. Correa, J. Rodriguez, and M. Pacas, "Control of a Single-Phase Cascaded H-Bridge Multilevel Inverter for Grid-Connected Photovoltaic Systems," *IEEE Trans. Ind. Electron.*, vol. 56, no. 11, pp. 4399–4406, 2009.

- [3] B. K. Bose, "Power Electronics And Motor Drives," *Power Electron. Mot. Drives Recent Prog. Perspect.*, vol. 56, no. 2, pp. 581–588.
- [4] J. D. van Wyk and F. C. Lee, "On a Future for Power Electronics," *IEEE J. Emerg. Sel. Top. Power Electron.*, vol. 1, no. 2, pp. 59–72, 2013.
- [5] J. Holtz, "Pulsewidth modulation - A survey," *IEEE Trans. Ind. Electron.*, vol. 39, no. 5, pp. 410–420, 1992.
- [6] J. Holtz, "Pulsewidth Modulation for Electronic Power Conversion," *Proc. IEEE*, vol. 82, no. 8, pp. 1194–1214, 1994.
- [7] Zhong. Du, L. M. Tolbert, B. Ozpineci, and J. N. Chiasson, "Fundamental frequency switching strategies of a seven-level hybrid cascaded H-bridge multilevel inverter," *IEEE Trans. Power Electron.*, vol. 24, no. 1, pp. 25–33, 2009.
- [8] Akira. Nabae, and H. Akagi, "A New Neutral-Point-Clamped PWM Inverter," *IEEE Trans. Ind. Appl.*, vol. 17 pp. 518–523, 1981.
- [9] M. F. Escalante, J. C. Vannier, and a Arzande, "Flying capacitor multilevel inverters and DTC motor drive applications," *Ind. Electron. IEEE Trans.*, vol. 49, no. 4, pp. 809–815, 2002.
- [10] Y. Ounejjar, K. Al-Haddad, and L.-A. Gregoire, "Packed U Cells Multilevel Converter Topology: Theoretical Study and Experimental Validation," *IEEE Trans. Ind. Electron.*, vol. 58, no. 4, pp. 1294–1306, 2011
- [11] D. Nazarpour, M. Sabahi, R. S. Alishah, and S. H. Hosseini, "New hybrid structure for multilevel inverter with fewer number of components for high-voltage levels," *IET Power Electron.*, vol. 7, no. 1, pp. 96–104, 2014.
- [12] R. Marquardt and A. Lesnicar, "A new modular voltage source inverter topology," *Eur. Power Electron. Conf.*, pp. 1–10, 2003.
- [13] Y. Liu, H. Hong, and A. Q. Huang, "Real-time calculation of switching angles minimizing THD for multilevel inverters with step modulation," *IEEE Trans. Ind. Electron.*, vol. 56, no. 2, pp. 285–293, 2009.
- [14] A. Jaqmal, C. Weindl, and G. Herold, "An Optimized Snubber Design for Three Level Inverter Systems," *EPE2005, Dresden, Ger.*, pp. 683–688, 2005.
- [15] J. Al-Nasseir, C. Weindl, G. Herold, and J. Flotthmesch, "A Dual-use Snubber Design for Multi-Level Inverter Systems," *2006 12th Int. Power Electron. Motion Control Conf.*, no. OCTOBER 2006, pp. 683–688, 2006.
- [16] Y. Ikeda, J. Itsumi, and H. Funato, "The power loss of the PWM voltage-fed inverter," in *Power Electronics Specialists Conference, 1988. PESC '88 Record., 19th Annual IEEE, 1988*, pp. 277–283 vol.1.
- [17] K. K. Gupta, A. Ranjan, P. Bhatnagar, L. K. Sahu, and S. Jain, "Multilevel inverter topologies with reduced device count: A review," *IEEE Trans. Power Electron.*, vol. 31, no. 1, pp. 135–151, 2016.
- [18] J. Leon, S. Kouro, L. Franquelo, J. Rodriguez, and B. Wu, "The Essential Role and the Continuous Evolution of Modulation Techniques for Voltage Source Inverters in Past, Present and Future Power Electronics," *IEEE Trans. Ind. Electron.*, vol. Early Acce, no. c, 2016.
- [19] Y. Ounejjar, K. Al-Haddad, and A. I. Alolah, "Averaged model of the 31-level packed U cells converter," *Proc. - ISIE 2011 2011 IEEE Int. Symp. Ind. Electron.*, pp. 1831–1836, 2011.