

International Journal of
Engineering Research and Science & Technology



ISSN : 2319-5991

www.ijerst.com

Email: editor@ijerst.com or editor.ijerst@gmail.com

IMPROVING POWER QUALITY OF A PV-INVERTER FOR THREE-PHASE SOLAR ENERGY CONVERSION SYSTEM WITH LEAKAGE CURRENT SUPPRESSION

¹MR.A. RADHA KRISHNA, ²NARAYANADASU NEHA SUSHEEL, ³PANDIGA BHARATH KUMAR, . ⁴MD.SALMAN

¹(Assistant professor), EEE. Guru Nanak Institutions Technical Campus, Hyderabad.

^{2,3,4}B.Tech Scholars, EEE. Guru Nanak Institutions Technical Campus, Hyderabad.

ABSTRACT

The improved power quality solar photovoltaic (PV) inverter that allows for the reduction of common-mode leakage current is presented in this work. This study examines a three-phase transformer-less solar energy conversion system (SECS), which provides grid reactive power support and peak active power production from photovoltaic arrays. It also ensures various power quality improvement capabilities, including grid current harmonic mitigation and grid current balancing. This approach, in contrast to traditional power quality inverters, is resilient to anomalies in grid voltages at distant radial ends and does not jeopardize the leakage currents brought on by the parasitic capacitance of the PV array with ground. PV leakage-currents are often ignored in PV inverter power quality management, despite the fact that they negatively impact system performance by lowering power quality and endangering operating staff safety. Therefore, the transformer-less PV systems are required to function with leakage current within the 300mA range per the standards VDE-00126 and NB/T-32004. Numerous test and simulation results demonstrate the offered strategy's good performance even in the presence of numerous grid-side anomalies. The efficiency of the method is shown by a comparison examination using cutting-edge techniques. The PV leakage currents are kept well within the range advised by the VDE-00126 standard, while the harmonics in the grid currents are noted within limitations as per the IEEE-519 and IEC-61727 standards under all test situations.

INDEX TERMS- Common mode voltage (CMV), Harmonics, Kalman filter (KF), Leakage Currents, Power quality and Voltage source Converter (VSC).

1. INTRODUCTION

The necessity for clean energy production and growing environmental concerns have caused a paradigm shift in favor of the creation of renewable electricity. Proactive actions are being implemented globally to stimulate a greater deployment of renewable energy sources and support the diversity of electrical power supply. In the last 10 years, solar PV-based systems have drawn particular interest due to their simplicity of installation and low maintenance costs. Traditional transformer-based grid-interfaced solar PV system topologies have higher losses and more complexity. This is the reason why many researchers have given transformer-less PV systems more thought.

The grid-tied solar PV array system provides a number of built-in benefits, including a discernible increase in efficiency and a decrease in the system's size, complexity, and total cost. However, as the solar energy conversion system lacks galvanic isolation, it can shorten the solar PV array's lifespan. The development of parasitic capacitances over the solar PV panel life-span of solar power systems results in the closed-loop route, which poses a risk to safety because of leakage current.

Researchers have developed a number of control techniques to lower the leakage currents in transformer-less PV systems in order to solve this problem. For example, several PV inverter control algorithms for single phase solar energy conversion systems are detailed in. Different strategies are analyzed to suppress the leakage currents in three phase SECS: H8 based proportional-resonant (PR) current controller with eight semiconductor switches, H7 based proportional complex integral (PCI) controller, and zero-voltage state rectifier (ZVR) based controller with nine semiconductor switches. Because the H9 arrangement can obtain a common mode voltage (CMV) that is fully ripple-free, it is very effective at reducing leakage currents. Instead of making the common mode voltage a ripple-free number, the H8 and H7 based techniques could only lessen the degree of the variations in that amount. Furthermore, the literature describes a number of techniques for reducing leakage current utilizing extra IGBT switches.

However, they are unable to implement several elements that improve power quality in distribution grids, and they are unable to operate well during high-voltage diversions that occur in weak distribution networks, particularly at the far radial ends. Researchers have previously considered a number of approaches to handle different power quality issues without changing the load profile. They use cascading voltage control loops to offer harmonic correction.

Multiple PR regulators, set at a certain frequency, are used in these loops to estimate the individual harmonic voltages from the common coupling point. However, when the system frequency deviates, the SECS's performance deteriorates. The research being done on leakage current suppression and power quality controllers that have been disclosed so far are not nearly able to meet both IEEE-519/IEC-61727 and VDE-00126/NB/T-32004 requirements at the same time.

In this regard, Table I provides a short explanation of some state-of-the-art controllers. In light of the previously mentioned discussion, this work presents an improved power quality PV-inverter that maintains leakage currents within VDE-00126 standard limits and delivers balanced, smooth sinusoidal currents into the grid, providing robust performance even under unbalanced or harmonically distorted grid voltages. By using a novel technique to derive improved unit templates, the balanced and sinusoidal currents are supplied into the grid at all disturbances. Thus, under harmonically distorted grid circumstances and unbalanced grid voltages, the negative sequence power that is being provided to the grid is canceled out, negating the influence of sequence powers on commercial and industrial loads.

Combining ZVR-based inverter switching control with hysteresis current management guarantees that the system can maintain the ripple-free common mode voltage under these conditions. Essentially, the following characteristics of a multi-functional PV-VSC are presented in this study.

- To guarantee improved power quality in the distribution system, instantaneous current reference generation based on Kalman filtering is used. Without knowing the phase, amount, or pattern of the grid current disturbances beforehand, KF dynamically forecasts the load fundamental currents.
- In accordance with VDE 00126 and NB/T-32004 requirements, reduced leakage current is achieved within 300 mA to provide protection against electrical shock.
- In accordance with IEEE-519 and IEC-61727 standards, balanced sinusoidal grid currents at unbalanced nonlinear loads are achieved with total harmonic distortions (THDs) within tolerances.
- To conform with IEEE1547 grid code [20]–[21], reactive power assistance is given to the grid under normal and abnormal distribution grids. Even in the event of symmetrical or asymmetrical failures, the controller can provide grid currents that are sinusoidal and balanced.
- At different dynamic situations, the efficacy of the provided controllers is stated in contrast with established algorithms.

Unlike traditional controllers, the suggested approach complies with grid standards even in the face of significant variations in grid voltage.

The efficacy of the plan that is being given is confirmed by means of many comparative assessments utilizing cutting-edge methodologies. The remainder of the paper is organized as follows. Section II contains a list of the system configuration diagrams. In Section III, the whole control system is explained. With the use of manifold simulation results, Section IV verifies the effectiveness of the controller in comparison to conventional controllers. Section V displays the laboratory test findings, while Section VI presents the study's conclusions.

2. RENEWABLE ENERGY SOURCES

2.1 INTRODUCTION

The nonconventional energy sources used in the project, such as the wind, hydro, photovoltaic, and battery systems, are briefly covered in this chapter along with any essential definitions and background information.

2.2 BLOCK DIAGRAM

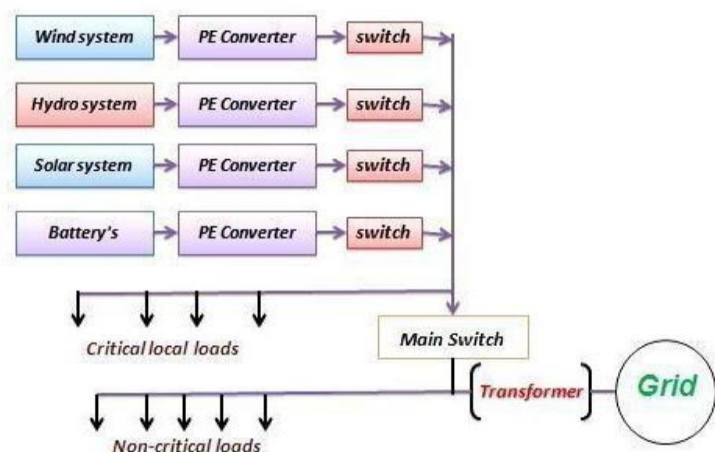

Fig: 2.2 Block diagram

2.3 SOLAR PHOTOVOLTAICS

2.3.1 Introduction

Becquerel was the first to notice the photovoltaic effect, which converts solar energy. It is usually understood to mean that when light is shone on a solid or liquid system, an electric voltage appears between two electrodes linked to the system. Solar cells are energy conversion devices that employ the photovoltaic effect to transform sunlight into electrical current. A solar cell, or more broadly a photovoltaic cell, is a single converter cell. A solar array, or solar module, is a group of these cells intended to maximize the generation of electric power; this is how the term "photovoltaic arrays" originates. Solar cells may be grouped together in enormous configurations known as arrays.

2.3.2 Basics of Solar Cells

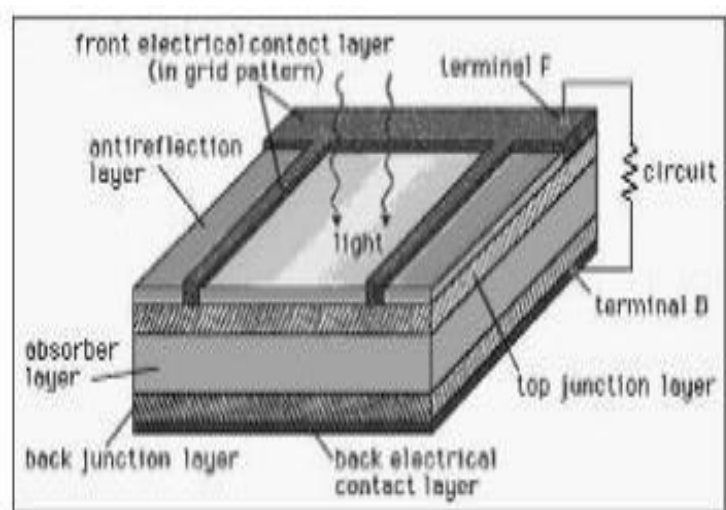

Silicon is used to create the vast majority of solar cells, and as silicon forms vary from amorphous (non-crystalline) to polycrystalline to crystalline (single crystal), the technology is becoming more and more efficient and less expensive. In contrast to batteries or fuel cells, solar cells don't need fuel or rely on chemical processes to generate electricity. Moreover, they are completely mechanically inert, unlike electric generators.

3. MAXIMUM POWER POINT TRACKER

3.1 PRINCIPLE OF MPPT

A high-efficiency DC to DC converter known as a maximum power point tracker, or MPPT, presents the ideal electrical load to a solar panel or array and generates a voltage appropriate for the load. PV cells have a single operational point when the cell's voltage (V) and current (I) values provide the highest possible power output. These numbers represent a specific load resistance, which Ohm's Law states is equal to V/I. The maximum power point (MPP) of a photovoltaic cell is found at the knee of the curve, when resistance equals the negative of differential resistance (V/I = -dV/dI). PV cells have an exponential connection between current and voltage. In order to find

this point and enable the converter circuit to draw the most power possible from a cell, maximum power point trackers use some kind of control circuit or logic.

3.2 ALGORITHM OF PERTURB OBSERVE METHOD

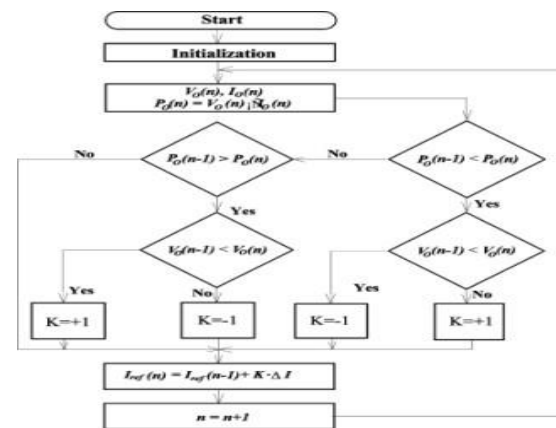

Fig 3.1: Flow chart of the MPPT algorithm with P&O method

3.3 Hill Climb Search Strategy

The form of the power curves for wind and photovoltaic arrays are similar, hence in order to harvest maximum power from both energy sources, a comparable maximum power point tracking approach called the hill climb search (HCS) strategy is often used. The HCS approach modifies the system's operating point while monitoring the result. The control algorithm will proceed in the direction of the preceding disturbance if the perturbation's direction (for example, a change in a PV array's output voltage) causes a positive change in the output power. On the other hand, the control algorithm will reverse the direction of the previous perturbation step if a negative change in the output power is seen. The method will not alter the system operating point if the power change is almost zero (within a certain range), since this corresponds to the highest power point, or the peak of the power curves.

technique: 3.4 MPPT The " β " approach, a Fast MPPT scheme, was appropriately adjusted and used for the specified purpose. The scheme is based on the observation that, as the MPP varies from PMPP(max) to PMPP(min) over the whole insolation and temperature range (λ_{max} , T_{max} to λ_{min} , T_{min}), as shown in the algorithm, the value of an intermediate variable " β ", defined only at MPP condition, varies within a narrow band ($\beta_{max} - \beta_{min}$). As a subset of β' , β may be applied at any point, including MPP, on the P-V curve.

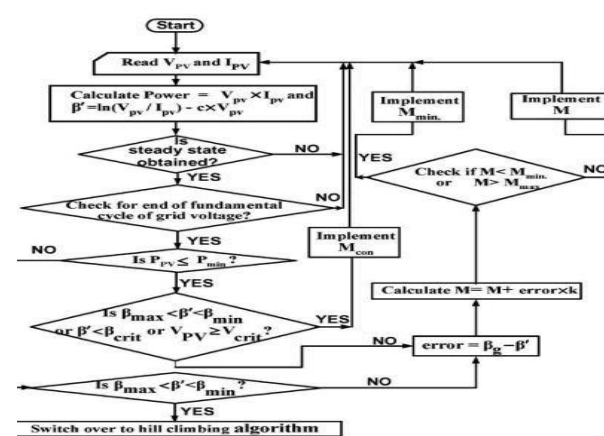

Fig 3.2: MPPT algorithm for β -method

β is obtained by using the MPP condition, $\partial P / \partial V = 0$ and is given by,

$$\beta = \ln(-I_o \times c) = \ln \frac{I_{sc}}{V_{pv}} - c \times V_{pv}$$

4. CONVERTERS AND INVERTERS

4.1 Boost Converters

When attempting to convert voltages using resistors (voltage dividers), we discovered that these methods had very low efficiency since a large portion of the power was lost to dissipation in the resistors rather than being used by the load. Furthermore, the voltage can only be lowered via dividers. This is a concern in a number of applications, including micro-electro-mechanical actuators (MEMS), which often need high voltages to function. Both issues may be solved using inductors and capacitors. Much greater transformation efficiencies are possible since these components (ideally) simply store

power—they don't dissipate it. This lab is dedicated to the design and testing of a unique kind of switching power supply known as a boost converter. The circuit is set up to create 15V from a 5V input by raising the input voltage to a higher value. See the schematic picture in Figure 1. The IRF510 gadget is a transistor. On the course website, get the datasheet. Only the arrow's direction is where the diode conducts current. Prior to doing an analysis of the circuit, we will assume that it is operational, namely that the output voltage is 15 V. Naturally, we will thereafter confirm that this is in fact the situation.

4.2 Single-phase voltage source inverters:

There are two topologies for single-phase voltage source inverters (VSIs): half-bridge and full-bridge. Despite their modest power range coverage, they are commonly used in single-phase UPSs, power supplies, and, as of late, complex high-power static power topologies, including the multicell setups that are examined. The following summarizes and presents the key components of both strategies.

Converters of Voltage Source (VSC)

A power electronic device that can produce a sinusoidal voltage with any desired magnitude, frequency, and phase angle is called a voltage-source converter. In addition to being often used in adjustable-speed drives, voltage source converters may also be employed to lessen voltage dips. The voltage may be fully replaced or the "missing voltage" can be injected using the VSC.

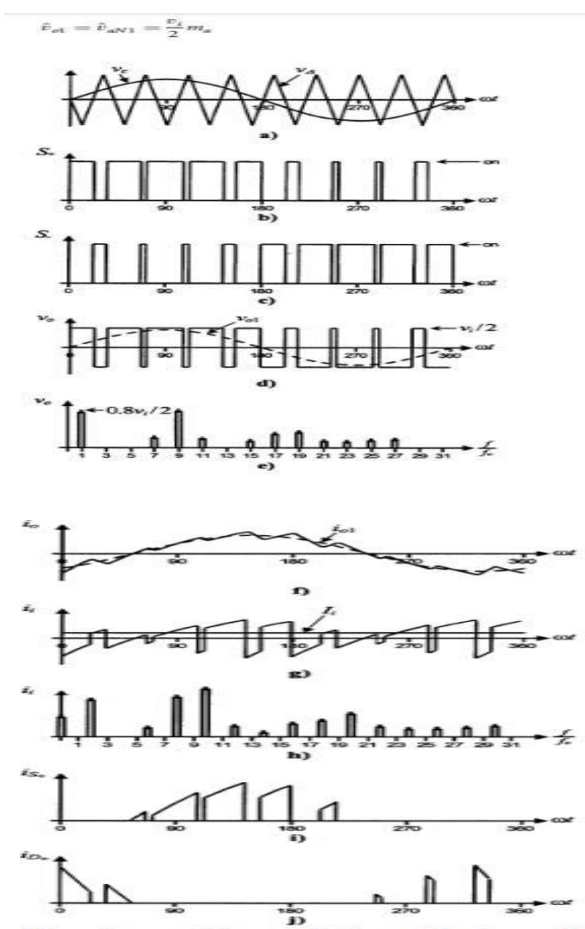

Fig. 5.1. Schematic block diagram of solar energy conversion system

5.1 MONITORY STUDY

This is the systematic control approach for gating the boost converter, the extra three switches, and power converter switches. The DC link voltage and the maximum power point are used to generate gating pulses for the DC-DC converter control. The PV array's reference voltage ($V_{PV\ ref}$) is found using the InC based MPPT. Next, the reference duty ratio is produced as,

$$d_{Boost}^{ref} = 1 - (V_{PV}^{ref} / V_{DC})$$

1) Prediction Step Initially, the in-phase and quadrature fundamental load components as in (5), are processed as [22],

$$\hat{x}_{k|k-1} = f(\hat{x}_{k-1|k-1})$$

$$f(\hat{x}_{k-1|k-1}) = F \hat{x}_{k-1|k-1}; F = \begin{bmatrix} \cos(k\omega_1 T_s) & \sin(k\omega_1 T_s) \\ -\sin(k\omega_1 T_s) & \cos(k\omega_1 T_s) \end{bmatrix}$$

2) Correction Step The in-phase and quadrature signals of the load fundamental component are then estimated using the correction step as,

$$\hat{x}_{k|k} = \hat{x}_{k|k-1} + K_k (y_k - g(\hat{x}_{k-1|k-1}))$$

6. SIMULATION RESULTS

6.1 SIMULATION CIRCUITS

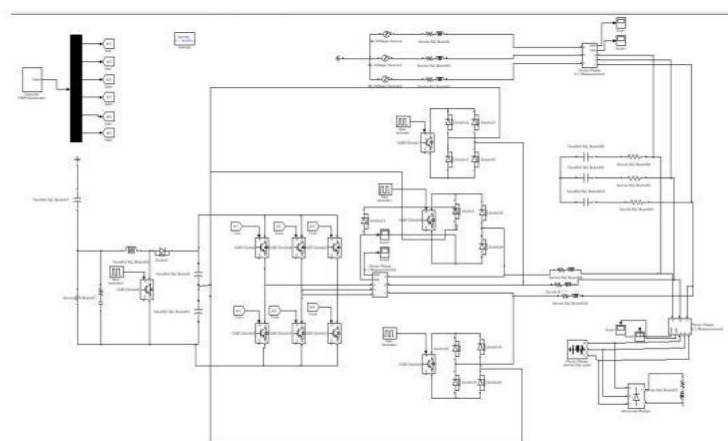

Fig: 6.1.Enhanced Power Quality PV-Inverter with Leakage Current Suppression for Three-Phase SECS

6.2 SIMULATION RESULTS

6.2.1 Output waveforms of solar three phase load change

5.SYSTEM CONFIGURATION

Fig. 5.1 shows the system schematic of the three phase grid connected photovoltaic system under consideration. A boost converter is used in a double-stage solar PV system to sustain the solar photovoltaic panel's maximum power output. The voltage source converter (VSC) serves as a mediator between the three-phase distribution grid and the solar panel. It should be mentioned that in addition to the VSC, three more switches and diode bridge rectifiers are used to balance the common mode voltages in order to reduce leakage current [10]. Additionally, a ripple filter is included to reduce the noise caused by VSC switching. Leakage current flow is aided by the parasitic capacitance.

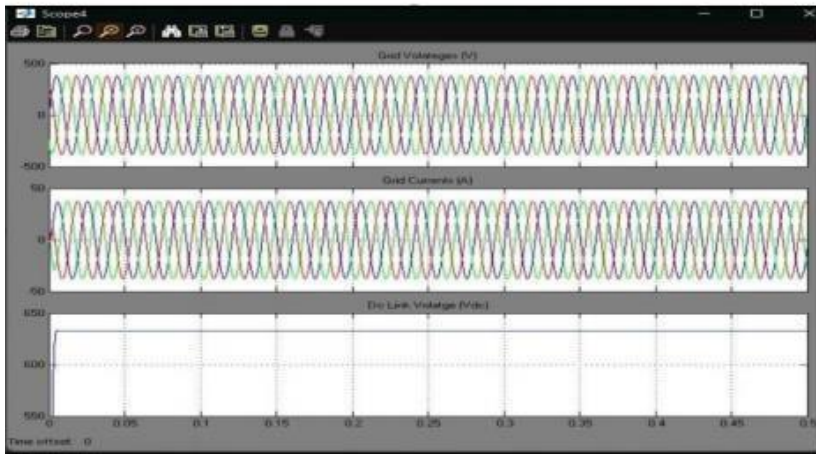

Fig: 6.2.1 output waveforms for solar three phase load change

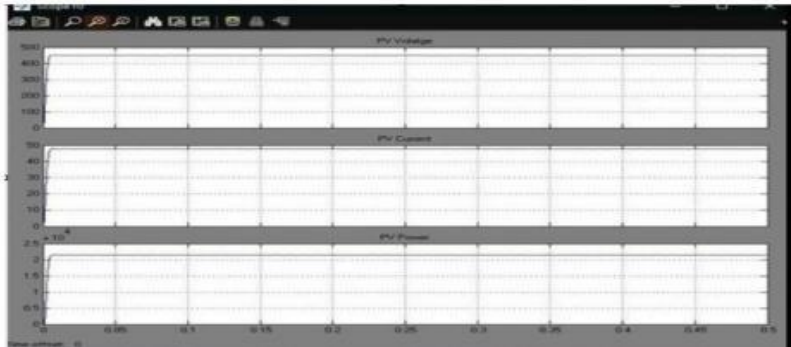

Fig: 6.2.2 output waveforms for solar three phase load change

6.3 Output waveforms of solar three phase isolation change

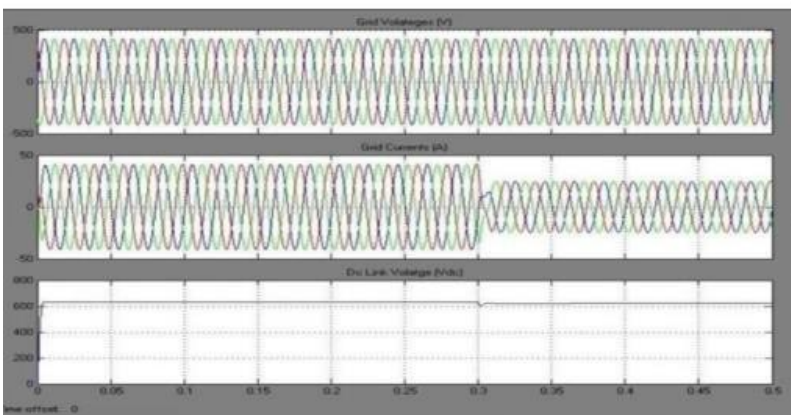

Fig: 6.3.1 output waveforms for solar three phase isolation change

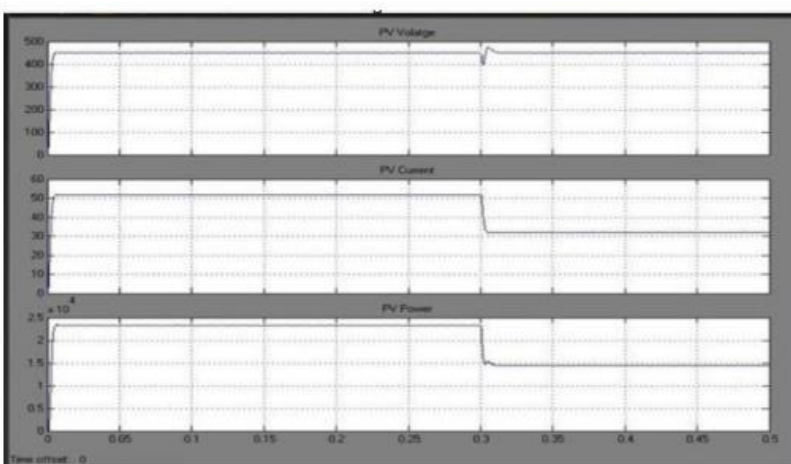

Fig:6.3.2 output waveforms for solar three phase isolation change

6.4 Output waveforms of solar three phase normal condition

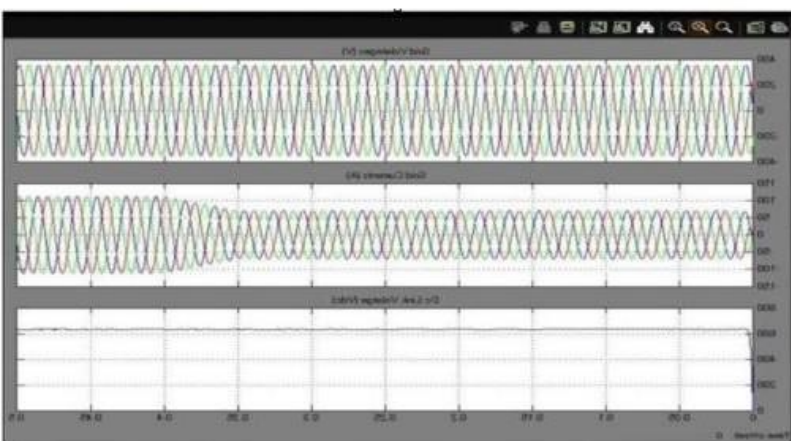

Fig: 6.4.1 output waveforms for solar three phase normal condition

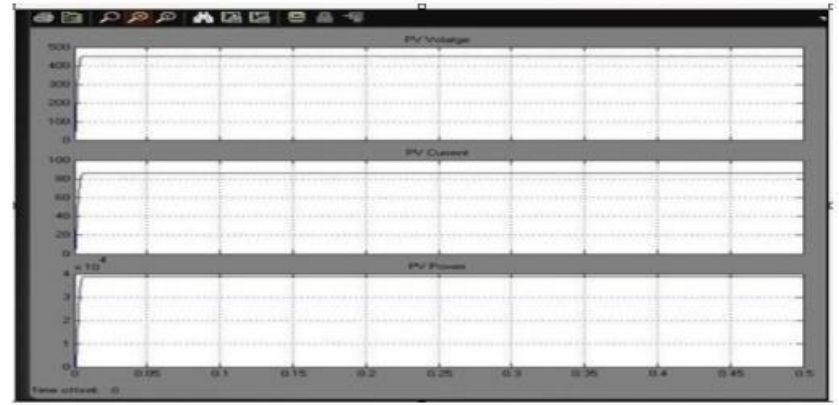

Fig: 6.4.2 output waveforms for solar three phase normal condition

7. CONCLUSIONS

For a two-stage grid-connected solar photovoltaic system, an efficient controller based on a Kalman state-estimator has been given. Its purpose is to ensure low leakage currents in compliance with NB/T-32004 and VDE-00126 standards and to handle power quality concerns in the grid under both normal and abnormal situations. Although solar PV parasitic capacitance is often ignored in power quality PV-inverters, it has a significant impact on system performance by reducing leakage currents, raising grid harmonic currents, and raising operating staff safety issues. Here, the system's large leakage currents are prevented while simultaneously preserving a steady, ripple-free common mode voltage. This controller inherits several multifunctional capabilities, including the ability to suppress harmonics, balance grid side network currents in the case of anomalous grid voltages, eliminate leakage currents, and support reactive power during grid side voltage sag failures.

As a result, it conforms with the VDE00126 leakage current norms and the IEEE-519 and IEC-61727 power quality standards. The effectiveness of the control strategy for SECS is shown by extensive modeling and test results under a variety of conditions, including load imbalances, anomalies in the grid voltages, and variations in solar insolation when PV stray capacitance is present. These findings demonstrate the suggested strategy's better reaction as compared to traditional controllers. The grid currents are seen to be balanced and sinusoidal, and the leakage currents are considerably reduced to 300mA, even despite the enormous diversions in grid voltage created at far-off radial ends. Because of its many capabilities and self-adapting features to the variations in the solar panel side as well as the grid side network, the proposed controller is a fine practical solution for the solar PV system, which is practically connected to the grid and subject to constant disturbances.

8. REFERENCES

- 1) vedantham Lakshmi Srinivas, Member, IEEE, Bhim Singh, Fellow, IEEE, and Sukumar Mishra, Senior Member, IEEE authored "Enhanced Power Quality PV-Inverter with Leakage Current Suppression for Three-Phase SECS" on August 31,2021.
- J. Buongiorno, M. Corradini, J. Parsons and D. Petti, "Nuclear energy in a carbonconstrained world: big challenges and big opportunities," IEEE Power and Energy Magazine, vol. 17, no. 2, pp. 69-77, Apr. 2019.
- 2) M. Z. Malik, A. Ali, G. S. Kaloi, A. M. Soomro, M. H. Baloch and S. T. Chauhdary, "Integration of renewable energy project: A technical proposal for rural electrification to local communities," IEEE Access, vol. 8, pp. 91448-91467, 2020.
- 3) S. Vedantham, S. Kumar, B. Singh and S. Mishra, "Fuzzy logic gain-tuned adaptive second-order GI-based multi-objective control for reliable operation of grid-interfaced photovoltaic system," IET Gen. Tran. Distrib., vol. 12, no. 5, pp. 1153-1163, 2018.
- 4) M. A. Awadallah, T. Xu, B. Venkatesh and B. N. Singh, "In the effects of solar panels on distribution transformers," IEEE Trans. Power Delivery, vol. 31, no. 3, pp. 1176-1185, June 2016.
- 5) W. Li, Y. Gu, H. Luo, W. Cui, X. He and C. Xia, "Topology review and derivation methodology of single-phase transformerless photovoltaic inverters for leakage current suppression," IEEE Trans. Ind. Electron., vol. 62, no. 7, pp. 4537-4551, July 2015.
- 6) E. Serban, C. Pondiche and M. Ordonez, "Modulation effects on power-loss and leakage current in three-phase solar inverters," IEEE Trans. Energy Conversion, vol. 34, no. 1, pp. 339-350, Mar. 2019.

- 7) S. Saridakis, E. Koutroulis and F. Blaabjerg, "Optimal design of modern transformerless PV inverter topologies," *IEEE Trans. Energy Conversion*, vol. 28, no. 2, pp. 394-404, June 2013.
- 8) B. Liu, M. Su, J. Yang, D. Song, D. He and S. Song, "Combined reactive power injection modulation and grid current distortion improvement approach for H6 transformer-less photovoltaic inverter," *IEEE Trans. Energy Conversion*, vol. 32, no. 4, pp. 1456-1467, Dec. 2017.
- 9) Z. Tang, Y. Yang, M. Su, T. Jiang, F. Blaabjerg, H. Dan, X. Liang, "Modulation for the AVC-HERIC inverter to compensate for deadtime and minimum pulsewidth limitation distortions," *IEEE Trans. Power Electronics*, vol. 35, no. 3, pp. 2571-2584, March 202