

# Touchless Dual-Mode Smart Door Lock System Using Smartphone Authentication and Bluetooth-Enabled Arduino with Solenoid Actuation

**Ms.Ashwini Prakashrao Rathod,**

lecturer in Electronics and Telecommunication Department ,  
Government Polytechnic kolhapur,  
[ashuberry2010@gmail.com](mailto:ashuberry2010@gmail.com)

**Ms.Roopali Bhaskar Palwe,**

Electronics and Computer Engineering,  
Maharashtra Institute of Technology,  
chh.Sambhajinagar(Aurangabad)  
[rbpalwe@gmail.com](mailto:rbpalwe@gmail.com)

## ABSTRACT

The rapid spread of infectious diseases such as COVID-19 has significantly increased the demand for touchless and secure access control systems. Traditional locking mechanisms and even fingerprint-based biometric systems require physical contact, which may facilitate the transmission of pathogens. To address this issue, this project presents a touchless smart door locking system that integrates smartphone-based authentication with Bluetooth communication. The system is developed using an Arduino Nano, HC-05 Bluetooth module, and a solenoid door lock. Instead of directly using a physical fingerprint sensor, the system leverages the smartphone's built-in biometric authentication, allowing users to unlock the door without physical contact. Once authenticated on the mobile device, a secure command is transmitted via Bluetooth to the Arduino controller, which processes the signal and activates the solenoid lock mechanism. This dual-mode approach enhances both security and convenience by combining biometric verification with wireless control. The proposed system is cost-effective, easy to implement, and suitable for residential, office, and institutional applications. It also supports multiple users and ensures reduced human contact, thereby contributing to improved hygiene and safety standards in access control systems.

**Keywords:** Smart Door Lock, Bluetooth Communication, Arduino Nano, Solenoid Lock, Smartphone Authentication, Contactless Security, Biometric System.

## I INTRODUCTION

In recent years, the advancement of embedded systems and wireless communication technologies has significantly transformed conventional security mechanisms into intelligent and automated solutions. Traditional mechanical locks, which rely on physical keys, are increasingly becoming obsolete due to their susceptibility to theft, duplication, and unauthorized access [1]. As a result, modern security systems are shifting towards digital and biometric-based authentication methods to enhance safety and reliability [2]. Biometric

systems, particularly fingerprint recognition, have gained widespread popularity due to their uniqueness and ease of use [3]. These systems are extensively employed in offices, educational institutions, and secure facilities for access control and attendance monitoring [4]. However, the outbreak of the COVID-19 pandemic has raised serious concerns regarding hygiene and physical contact associated with fingerprint-based systems [5]. Since these systems require users to touch a shared sensor surface, they can act as potential carriers for virus transmission [6].

To overcome these limitations, contactless technologies have emerged as a safer alternative. Among these, smartphone-based authentication has gained prominence due to its widespread availability and advanced security features such as fingerprint recognition, face recognition, and PIN verification [7]. Smartphones are now equipped with highly secure biometric sensors, making them reliable tools for user authentication without requiring additional hardware [8]. By leveraging these capabilities, it is possible to design a system where authentication is performed on the user's personal device, thereby eliminating the need for shared contact surfaces [9]. Wireless communication technologies such as Bluetooth further enhance the functionality of smart security systems by enabling seamless interaction between devices [10]. The HC-05 Bluetooth module, in particular, is widely used in embedded applications due to its low cost, ease of integration, and reliable performance [11]. It allows communication between a smartphone and a microcontroller, enabling remote control of devices such as door locks [12].

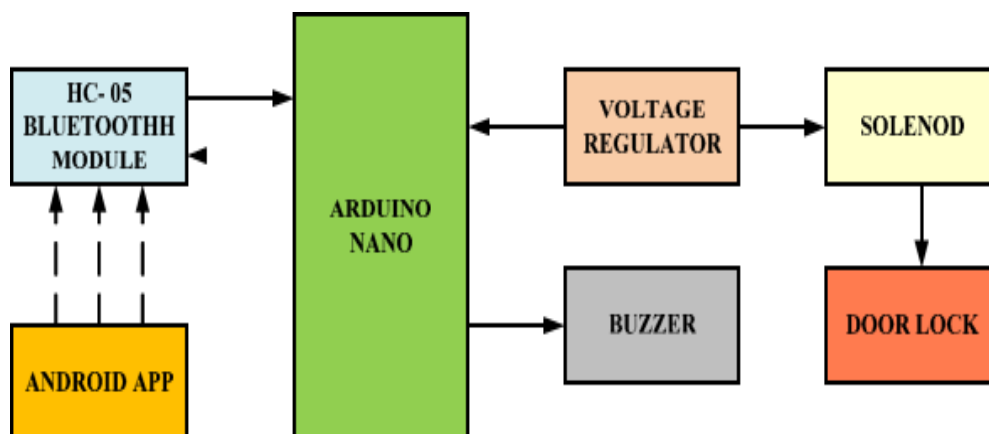

*Figure 1. Block Diagram*

Arduino-based systems have become a popular choice for developing such applications due to their simplicity, flexibility, and open-source nature [13]. The Arduino Nano, with its compact size and sufficient processing capability, is well-suited for implementing embedded security systems [14]. When combined with a solenoid lock, the Arduino can effectively control the locking and unlocking mechanism based on received commands [15]. The proposed system integrates smartphone-based biometric authentication with Bluetooth communication to create a touchless and secure door locking mechanism. In this system, the user authenticates themselves using their smartphone's fingerprint sensor, after which a command is transmitted via Bluetooth to the Arduino controller [16]. Upon receiving the authenticated signal, the Arduino activates the solenoid lock, allowing access to the user [17]. This approach not only

enhances security but also minimizes physical contact, making it highly suitable in post-pandemic scenarios [18]. Furthermore, the system is designed to be cost-effective and easy to implement, making it accessible for a wide range of applications, including residential homes, offices, and restricted access areas [19]. The integration of multiple technologies such as embedded systems, wireless communication, and biometric authentication demonstrates the potential of smart systems in improving security and user convenience [20].

## LITERATURE SURVEY

Numerous research efforts have been undertaken to improve the security and efficiency of door locking systems using modern technologies. Early systems primarily relied on mechanical locks, which were later enhanced with electronic keypads and password-based access systems [1]. Although these systems provided a basic level of security, they were vulnerable to password theft and unauthorized access [2]. Biometric authentication systems, particularly fingerprint-based systems, marked a significant advancement in access control technology [3]. These systems utilize unique physiological characteristics of individuals, making them more secure compared to traditional methods [4]. Several studies have demonstrated the effectiveness of fingerprint-based door locks in enhancing security and reducing unauthorized access [5]. However, these systems require physical contact with the sensor, which has become a concern in the context of infectious diseases [6]. To address these limitations, researchers have explored contactless authentication methods such as RFID and facial recognition systems [7]. RFID-based systems allow users to unlock doors using cards or tags, but they are prone to issues such as card loss or duplication [8]. Facial recognition systems, on the other hand, provide a completely contactless solution but often require complex image processing algorithms and high computational resources [9]. Recent advancements have focused on integrating smartphones into access control systems. Smartphones offer multiple authentication methods, including fingerprint scanning, facial recognition, and secure PIN entry [10]. Several studies have proposed systems where smartphones communicate with microcontrollers via Bluetooth or Wi-Fi to control door locks [11]. These systems eliminate the need for additional biometric hardware and provide a more user-friendly experience [12].

Bluetooth-based systems, particularly those using the HC-05 module, have gained popularity due to their simplicity and low cost [13]. Researchers have demonstrated that Bluetooth communication is sufficient for short-range applications such as home security systems [14]. These systems allow users to control door locks through mobile applications, providing both convenience and flexibility [15]. Arduino-based implementations have been widely adopted in research due to their ease of programming and compatibility with various sensors and modules [16]. Studies have shown that Arduino can effectively process authentication signals and control actuators such as solenoid locks [17]. The integration of Arduino with Bluetooth modules enables real-time communication between devices, making it suitable for smart home applications [18]. The use of solenoid locks in electronic door systems has also been extensively studied. Solenoid locks provide a reliable and efficient mechanism for controlling access, as they can be easily interfaced with microcontrollers [19]. When combined with authentication systems, they offer a robust solution for secure access control [20]. In summary, the literature indicates a clear trend towards contactless, smartphone-based authentication

systems that leverage wireless communication and embedded technologies. While traditional biometric systems provide strong security, their reliance on physical contact limits their applicability in modern scenarios. The proposed system builds upon existing research by combining smartphone authentication with Bluetooth communication and Arduino-based control, resulting in a secure, cost-effective, and touchless door locking solution.

## HARDWARE DESCRIPTION

The Arduino Nano is a small, complete, and breadboard-friendly board based on the ATmega328. It has more or less the same functionality of the Arduino Duemilanove, but in a different package. It lacks only a DC power jack, and works with a Mini-B USB cable instead of a standard one.

The Arduino Nano as the name suggests is a compact, complete and bread-board friendly microcontroller board. The Nano board weighs around 7 grams with dimensions of 4.5cms to 1.8cms (L to B). This article discusses about the technical specs most importantly the pinout and functions of each and every pin in the Arduino Nano board.

Arduino Nano has similar functionalities as Arduino Duemilanove but with a different package. The Nano is inbuilt with the ATmega328P microcontroller, same as the Arduino UNO. The main difference between them is that the UNO board is presented in PDIP (Plastic Dual-In-line Package) form with 30 pins and Nano is available in TQFP (plastic quad flat pack) with 32 pins. The extra 2 pins of Arduino Nano serve for the ADC functionalities, while UNO has 6 ADC ports but Nano has 8 ADC ports. The Nano board doesn't have a DC power jack as other Arduino boards, but instead has a mini-USB port. This port is used for both programming and serial monitoring. The fascinating feature in Nano is that it will choose the strongest power source with its potential difference, and the power source.

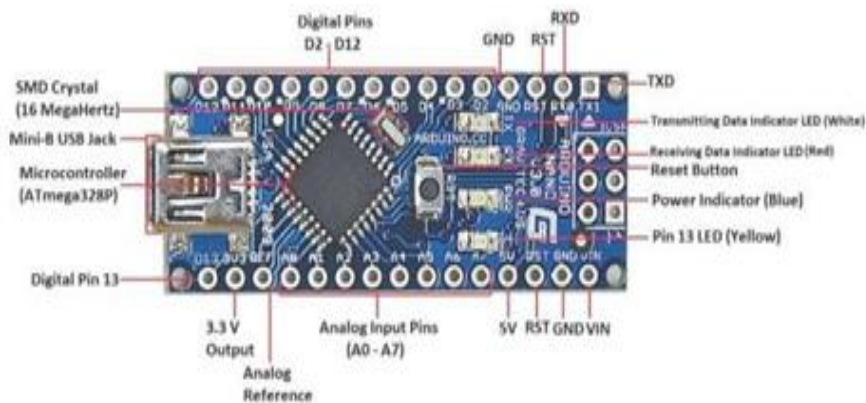
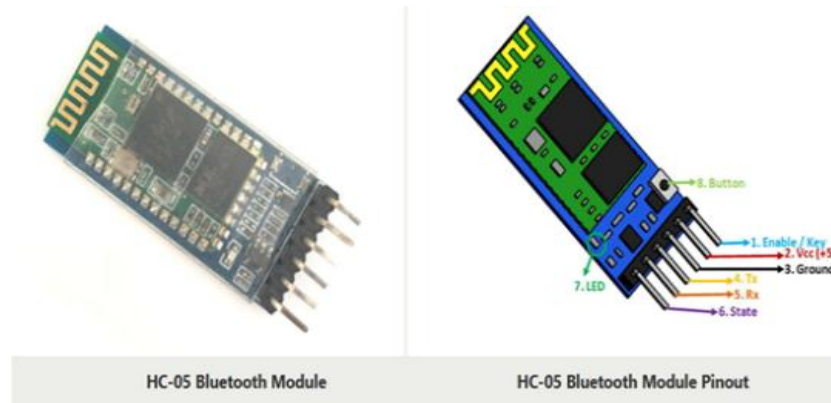

**Figure 2.Arduino Pin Reference**

## HC-05 BLUETOOTH MODULE

The HC-05 is a popular module which can add two-way (full-duplex) wireless functionality to your projects. You can use this module to communicate between two micro-controllers like Arduino or communicate with any device with Bluetooth functionality like a Phone or Laptop. There are many android applications that are already available which makes this process a lot easier. The module communicates with the help of USART at 9600 baud rate hence it is easy to interface with any micro-controller that supports USART. We can also configure the default

values of the module by using the command mode. So if you looking for a Wireless module that could transfer data from your computer or mobile phone to micro- controller or vice versa then this module might be the right choice for you. However do not expect this module to transfer multimedia like photos or songs; you might have to look into the CSR8645 module for that.



**Figure 3. HC 05 Bluetooth Module**

### SOLENOID LOCK

The solenoid lock is also known as the Electric strike lock. It can be used to lock or unlock doors, cabinets, and drawer.

Inside the solenoid valve:

1. There is a coil of insulated copper wire which is wound in the shape of a hollow cylinder.
2. There is an armature inside the coil which moves freely.
3. When we pass the electric current to the coil it generates a magnetic field near it.
4. The movement of the armature depends on the magnetic field generated by the insulated copper coil.



**Figure 4: Solenoid Lock**

### Buzzer

A buzzer is a small yet efficient component to add sound features to our project/system. It is very small and compact 2-pin structure hence can be easily used on breadboard, Perf Board and even on PCBs which makes this a widely used component in most electronic applications.



**Figure .5: Buzzer**

There are two types of buzzers that are commonly available. The one shown here is a simple buzzer which when powered will make a Continuous Beeeeeeppp sound, the other type is called a readymade buzzer which will look bulkier than this and will produce a Beep. Beep. Beep. Sound due to the internal oscillating circuit present inside it. But, the one shown here is most widely used because it can be customized with help of other circuits to fit easily in our application.

This buzzer can be used by simply powering it using a DC power supply ranging from 4V to 9V. A simple 9V battery can also be used, but it is recommended to use a regulated +5V or +6V DC supply. The buzzer is normally associated with a switching circuit to turn ON or turn OFF the buzzer at required time and require interval.

**LED**

A light-emitting diode (LED) is a semiconductor device that emits light when an electric current flows through it. When current passes through an LED, the electrons recombine with holes emitting light in the process. LEDs allow the current to flow in the forward direction and blocks the current in the reverse direction. When the diode is forward biased, the minority electrons are sent from p → n while the minority holes are sent from n → p. At the junction boundary, the concentration of minority carriers increases.

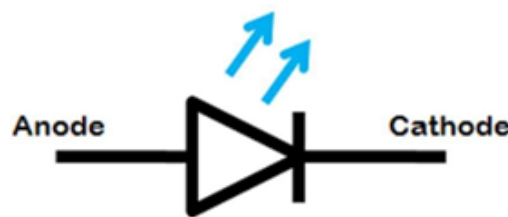

Figure 6.Symbol of LED

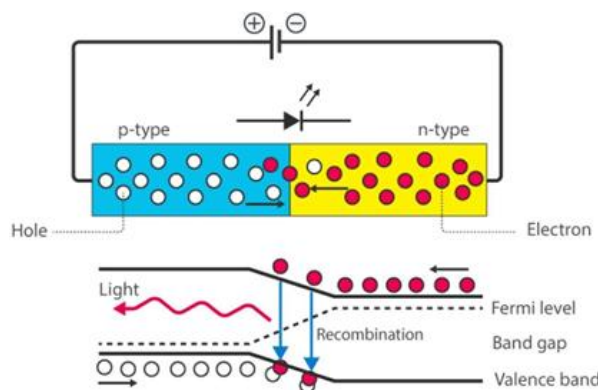

Figure.7: Working of LED

## RELAY

A Relay is a device that opens or closes an auxiliary circuit under some pre-determined condition in the Main circuit. The object of a Relay is generally to act as a sort of electric magnifier, that is to say, it enables a comparatively weak current to bring in to operation on a much stronger current. It also provides complete electrical isolation between the controlling circuit and the controlled circuit.



## CIRCUIT CONNECTIONS AND RESULT

The above circuit diagram shows how to interface and control a solenoid lock with an Arduino through a MOSFET.

As shown in the above circuit diagram we need to connect the HC-05 Bluetooth module to the nano by powering the device with a 5V power supply and connect the TX pin to RX pin of your microcontroller and RX pin to the TX pin of the microcontroller.

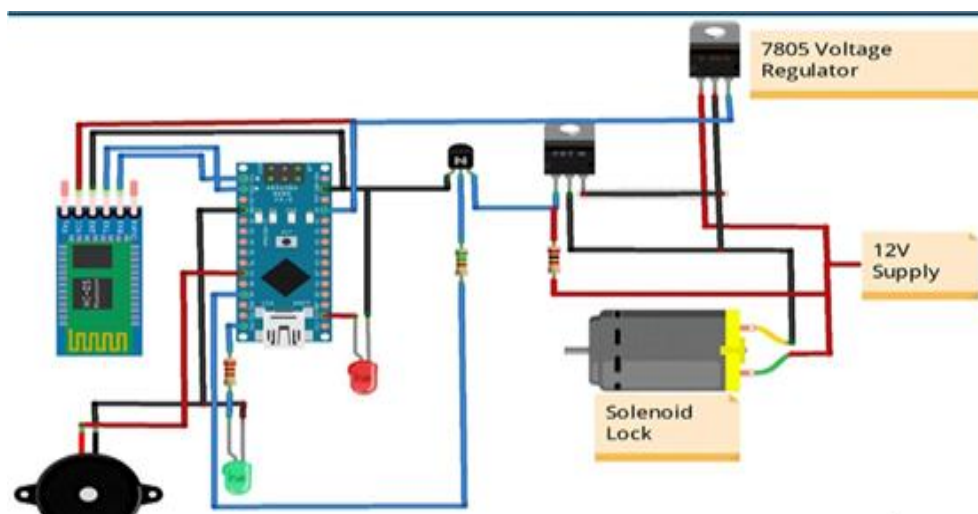

Figure .8: Hardware Circuit Diagram

We need to add a red LED to display the power status of the Arduino nano and a green LED to show if the door is unlocked. We should also need to connect a buzzer. If we give wrong fingerprint then the buzzer will On and make sound.

The prototype of the Cell-phone controlled solenoid door lock using Arduino and HC-05 is shown below:

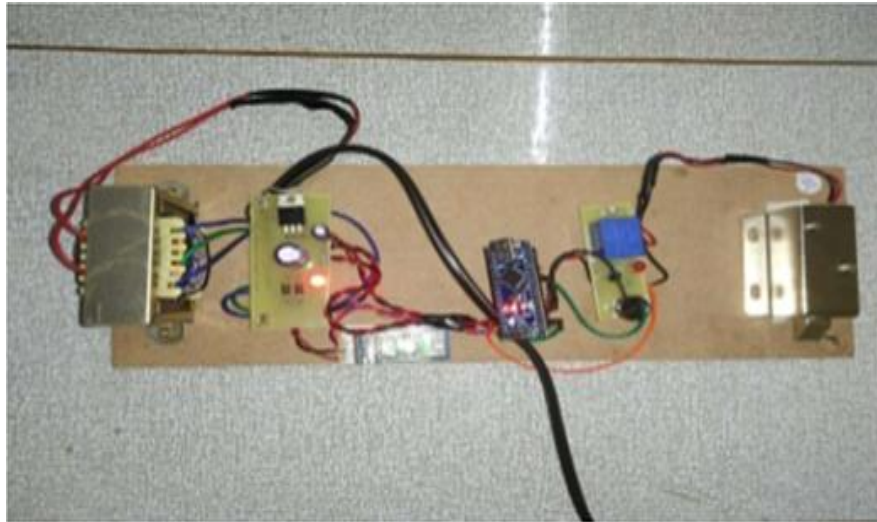

Figure 9. Working Module

### Advantages

1. High security and assurance
2. Flexible system is customized and Flexible
3. Easy to use
4. Non transferable
5. Accountability

### Disadvantages

1. Different biometric technologies need the use of different devices that have a range of cost.
2. Entry and delete fingerprints need to operate multiple steps, the program is too much trouble, convenience is not enough.
3. Performance can be fluctuated to dry, wet, dirty fingers.

### Applications

1. Used in Biometric door locks
2. Theft protection
3. Safe lockers
4. Fingerprint security system in car
5. Office security

### Conclusion

The project work is successfully designed tested and a demo unit is fabricated. Since it is a demonstration unit, facility is provided only for single relay, but for real application hundreds of relays may be used depending upon the area of the field. In this project work the required power supply for the entire circuitry is derived from the main source, since the circuitry to be installed at fields, and availability of conventional energy at fields may be difficult, therefore this supply can be generated using solar energy. For this purpose suitable solar panel can be utilized for charging the battery and the stored energy from the battery can be utilized to generate required power supply for the circuitry.

### Future Scope

1. Advancements in biometric identification management technology are moving so fast, In future we will make advancement and multi functions like SMS alert if authorized person try to lock the door.
2. Image recognizing process system and password system based.
3. Eye's retina for password which helps authorized persons for authentication for entrance so biometric technology makes individual convenient in real life

### REFERENCES

- [1] J. Baidya, T. Saha, R. Moyashir, and R. Palit, "Design and implementation of a fingerprint-based lock system for shared access," in *Proc. IEEE 7th Annual Computing and Communication Workshop and Conference (CCWC)*, 2017, pp. 1–6. ([Scribd](#))
- [2] N. Meenakshi, M. Monish, K. J. Dikshit, and S. Bharath, "Arduino based smart fingerprint authentication system," in *Proc. 1st Int. Conf. Innovations in Information and Communication Technology (ICIICT)*, 2019, pp. 1–7. ([IJARST](#))
- [3] A. K. Jain, A. Ross, and S. Prabhakar, "An introduction to biometric recognition," *IEEE Trans. Circuits Syst. Video Technol.*, vol. 14, no. 1, pp. 4–20, Jan. 2004. ([IJARST](#))
- [4] R. P. Wildes, "Iris recognition: An emerging biometric technology," *Proc. IEEE*, vol. 85, no. 9, pp. 1348–1363, 1997. ([IJARST](#))
- [5] M. F. Areed, "A keyless entry system based on Arduino board with Wi-Fi technology," *Measurement*, vol. 139, pp. 34–39, 2019. ([IJARST](#))
- [6] M. S. Bonaventure, S. Priyadarshini, S. Nayak, and A. Ushadevi, "Smart key: Secure door lock system using NFC enabled smartphone," *Int. J. Inf. Technol.*, vol. 6, no. 2, pp. 67–70, 2017. ([The Science and Information Organization](#))
- [7] A. Tailor and V. Pandya, "IoT-based smart door lock system," *Int. J. Res. Appl. Sci. Eng. Technol.*, vol. 11, no. 3, pp. 922–926, 2023. ([The Science and Information Organization](#))
- [8] S. Kaya, E. A. Ayyıldız, and M. Ayyıldız, "Smart door lock design with Internet of Things," *Int. J. 3D Printing Technol. Digit. Ind.*, vol. 6, no. 2, pp. 201–206, 2022. ([The Science and Information Organization](#))
- [9] R. W. Tambunan, A. A. Ar-Rafif, and M. Galina, "Multi-security system based on RFID, fingerprint, and keypad," *Elkha*, vol. 14, no. 2, p. 125, 2022. ([The Science and Information Organization](#))
- [10] S. Jeong, "Design on novel door lock using minimizing physical exposure and fingerprint recognition technology," *Int. J. Informatics Vis.*, vol. 6, no. 1, pp. 103–108, 2022. ([The Science and Information Organization](#))
- [11] S. Kadam, "IoT-based smart door lock system with ESP32-CAM," *Int. J. Res. Appl. Sci. Eng. Technol.*, vol. 9, no. 6, pp. 4713–4716, 2021. ([The Science and Information Organization](#))

- [12] A. B. de Lima, B. Gurung, and S. M. Farhad, “Efficient app-based smart door lock system using Bluetooth,” in *Proc. WAINA*, 2020, pp. 1046–1055. ([Academia](#))
- [13] M. Almosawi, “IoT security applied on a smart door lock application,” 2018. ([The Science and Information Organization](#))
- [14] A. Afolabi and A. O. Alice, “On securing a door with fingerprint biometric technique,” *Trans. Mach. Learn. Artif. Intell.*, vol. 2, pp. 86–96, 2014. ([Scribd](#))
- [15] D. Bhatia and A. Anu, “A smart door access system using fingerprint biometric system,” *Int. J. Med. Eng. Informatics*, vol. 6, no. 3, pp. 274–280, 2014. ([IARJSET](#))
- [16] K. Shafin et al., “Development of an RFID based access control system,” in *Proc. IEEE ICIECS*, 2015, pp. 1–5. ([IJARSCT](#))
- [17] P. K. Patil et al., “Smart door locking system using IoT,” *Int. J. Adv. Res.*, 2020. ([IJARSCT](#))
- [18] S. Motwani, “Multifactor door locking systems: A review,” *Mater. Today Proc.*, 2021. ([ScienceDirect](#))
- [19] S. B. et al., “Fingerprint door lock using Arduino UNO R3,” *Int. J. Multidisciplinary Res.*, vol. 5, no. 3, 2023. ([The Science and Information Organization](#))
- [20] R. Teli, S. Sharma, R. Singh, and B. Ameta, “Implementation of a fingerprint-activated door lock using Arduino UNO,” *IARJSET*, 2024. ([IARJSET](#))