



# International Journal of Engineering Research and Science & Technology

[www.ijerst.org](http://www.ijerst.org)

ISSN : 2319-5991



Vol. 15 No. 3 (2019)



[ijerst.editor@gmail.com](mailto:ijerst.editor@gmail.com)  
[editor@ijerst.com](mailto:editor@ijerst.com)

*Research Paper*

## **Design of a FOPID-Based Hybrid Transformer less PV Inverter with Reactive Power Compensation and Leakage Current Suppression**

**Lata Bala Awale**

Assistant professor,

Department of Electrical Engineering,

Government College of Engineering Chandrapur

[lata.dupare@gmail.com](mailto:lata.dupare@gmail.com)

### **ABSTRACT**

This paper proposes a hybrid transformerless single-phase grid-connected photovoltaic (PV) inverter controlled using a Fractional Order Proportional–Integral–Derivative (FOPID) strategy to enhance system performance and power quality. Transformerless inverters, while efficient and compact, often suffer from issues such as leakage current and limited capability for reactive power support. To address these challenges, the proposed topology integrates mid-point clamping and decoupling techniques to stabilize the common-mode voltage, thereby effectively minimizing leakage current. The incorporation of the FOPID controller significantly improves dynamic performance, robustness, and tracking accuracy under varying environmental and load conditions, including fluctuations in solar irradiance and grid disturbances. The system also enables independent control of active and reactive power, facilitating reactive power compensation and contributing to grid voltage stability. Simulation studies conducted in MATLAB/Simulink demonstrate that the proposed system achieves superior performance in terms of reduced total harmonic distortion (THD), improved waveform quality, and faster transient response compared to conventional control approaches. Additionally, the design ensures compliance with grid standards while maintaining high efficiency and operational safety. Overall, the proposed inverter configuration presents a reliable, efficient, and compact solution for modern grid-connected PV systems, making it a suitable candidate for next-generation renewable energy integration.

**Keywords :** Transformerless PV Inverter, FOPID Controller, Leakage Current Reduction, Reactive Power Compensation, Grid-Connected Systems, Power Quality Improvement, Solar Photovoltaic System.

### **I INTRODUCTION**

In recent decades, the global energy landscape has undergone a significant transformation driven by the depletion of fossil fuel resources and growing concerns over environmental sustainability. The adverse impact of carbon emissions, along with the urgent need for sustainable development, has encouraged nations worldwide to adopt cleaner and renewable energy sources. Among these, solar photovoltaic (PV) systems have emerged as one of the most promising solutions due to their abundance, scalability, and decreasing installation costs [1]. The increasing deployment of grid-connected PV systems has further enabled decentralized power generation, thereby reducing transmission losses and improving overall system reliability [2]. Historically, PV systems were primarily used in standalone or specialized applications. However, advancements in power electronics and control strategies have facilitated their seamless integration into utility grids. Despite these developments, grid integration of PV systems presents several technical challenges, particularly in terms of power quality, operational safety, and compliance with evolving grid standards [3]. As a result, the design of efficient and reliable inverter systems—serving as the critical interface between the PV array and the grid—has become a key focus in modern power system research.

Conventionally, grid-connected PV systems utilized low-frequency transformers to provide galvanic isolation, ensuring safety and eliminating leakage current issues. Although these systems are reliable, they are associated with significant disadvantages, including increased size, weight, cost, and reduced efficiency [4]. To overcome these limitations, transformerless inverter topologies have been developed, offering higher efficiency, compact design, and improved power density. However, the absence of galvanic isolation introduces a major challenge: leakage current caused by parasitic capacitances between the PV array and ground [5]. This leakage current is primarily induced by variations in common-mode voltage during high-frequency switching operations. Such currents not only reduce system efficiency but also create serious safety concerns, including the risk of electric shock and electromagnetic interference [6]. Furthermore, excessive leakage current can lead to improper operation of protection mechanisms and failure to comply with established safety standards [7]. Therefore, effective mitigation of leakage current has become a critical design requirement in transformerless PV inverter systems.

Over the years, numerous inverter topologies, such as H5, H6, HERIC, and neutral-point-clamped structures, have been proposed to address this issue [8]. Each of these configurations offereth certain advantages in reducing leakage current; nevertheless, they often entail increased circuit complexity, additional components, or limitations in operational flexibility. Furthermore, many of these designs are constrained to operate at unity power factor, thereby neglecting the necessity for reactive power support, which is indispensable for maintaining voltage stability in modern grids [9]. In contemporary electrical networks, the role of distributed generation systems hath evolved from passive power injection to active participation in grid regulation. Utilities now require PV inverters to provide ancillary services, including reactive power compensation, voltage support, and harmonic mitigation [10]. This transition necessitates the development of advanced inverter systems capable of independently controlling active and reactive power without compromising system stability or safety. Accordingly, the incorporation of decoupled control strategies hath gained prominence in recent research endeavours [11].

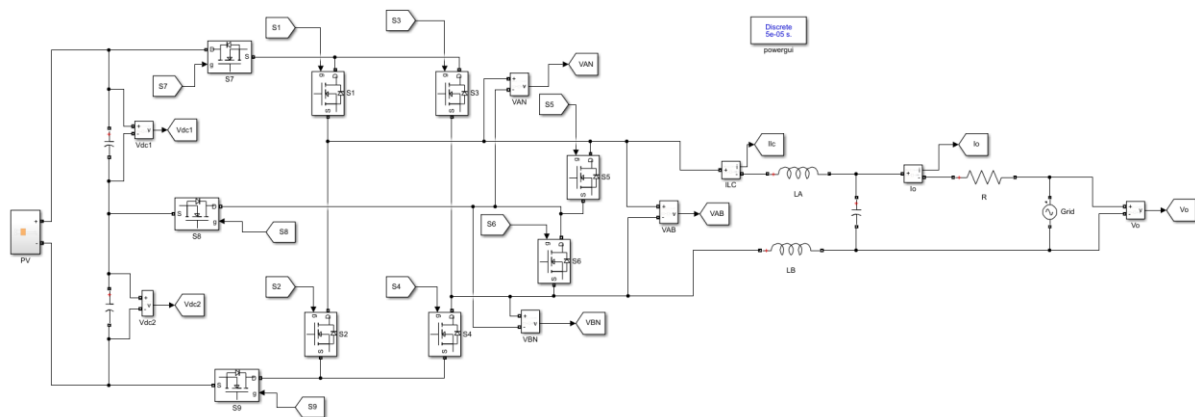

Fig 1 MATLAB/SIMULINK circuit diagram of the system

Equally significant is the role of control algorithms in determining the performance of inverter systems. Conventional proportional–integral–derivative (PID) controllers, though widely utilised, often exhibit limitations in handling nonlinearities, parameter variations, and external disturbances [12]. Such shortcomings may result in inferior dynamic response, increased steady-state error, and reduced robustness under practical operating conditions [13]. In light of these deficiencies, more sophisticated control techniques, including model predictive control, sliding mode control, and artificial intelligence-based approaches, have been explored [14]. Among these advanced methodologies, the Fractional Order PID (FOPID) controller hath garnered considerable attention due to its enhanced flexibility and superior performance characteristics. By extending the concept of integer-order calculus to fractional orders, the FOPID controller introduceth additional tuning parameters, thereby affording greater control over system dynamics [15]. This capability enableth improved transient response, reduced overshoot, and enhanced disturbance rejection, rendering it particularly suitable for power electronic applications [16].

Notwithstanding its merits, the application of FOPID control in transformerless PV inverters remaineth relatively limited, especially in conjunction with topologies designed for leakage current mitigation and reactive power support [17]. Therefore, there existeth a pressing need for an integrated approach that combineth an efficient inverter topology with an advanced control strategy to achieve optimal performance. In addition to control considerations, the regulation of common-mode voltage is of paramount importance in mitigating leakage current. Techniques such as mid-point clamping and decoupling have been proposed to stabilise the inverter potential and minimise voltage fluctuations [18]. These approaches, when judiciously combined, may significantly reduce both peak and RMS leakage currents whilst maintaining system efficiency [19]. Furthermore, the ability to operate under both unity and non-unity power factor conditions is essential for modern PV systems. The independent control of active and reactive power enableth the inverter to contribute to grid stability, particularly in weak or heavily loaded networks [20]. Such functionality is increasingly mandated by international grid codes, thereby necessitating the development of versatile and compliant inverter systems [21].

Simulation tools, such as MATLAB/Simulink, have played a vital role in validating novel inverter designs and control strategies. Through comprehensive modelling and analysis, researchers are able to evaluate system performance under diverse operating conditions, including irradiance variations, load disturbances, and grid faults [22]. Experimental validation further substantiates the practical feasibility of proposed solutions, ensuring their readiness for real-world deployment [23]. In recent years, considerable research efforts have been directed towards enhancing the efficiency, reliability, and intelligence of PV inverter systems. The integration of advanced controllers, optimisation algorithms, and hybrid topologies hath yielded promising results in improving power quality and reducing harmonic distortion [24]. Nevertheless, challenges persist in achieving a harmonious balance between efficiency, safety, and grid support capabilities [25]. Thus, the present work seeketh to address these challenges by proposing a hybrid transformerless inverter topology integrated with a FOPID controller. The proposed system endeavoureth to reduce leakage current, enhance dynamic performance, and enable reactive power compensation, thereby fulfilling the requirements of modern grid-connected PV systems [26]. By combining innovative circuit design with advanced control techniques, the system aimeth to provide a robust and efficient solution for renewable energy integration [27]. In summation, the evolution of photovoltaic inverter technology hath reached a juncture where both topological innovation and control sophistication are indispensable. The pursuit of improved performance, safety, and grid compatibility continueth to drive research in this domain [28]. The proposed approach representeth a significant step towards achieving these objectives, offering a comprehensive solution that addresseth the multifaceted challenges of contemporary PV systems [29], [30].

## II LITERATURE SURVEY

The scholarly endeavours pertaining to photovoltaic (PV) systems and transformerless inverter technologies have, over the past decades, expanded considerably, reflecting the growing necessity for efficient, reliable, and sustainable energy solutions. Early investigations into PV deployment, as elucidated in contemporary global reports, reveal a substantial increase in installed capacity, accompanied by a marked reduction in system costs and improvements in module efficiency [1]. Such developments have rendered PV systems a principal contributor to modern electrical power generation, thereby necessitating continued research into their effective integration with utility grids. A considerable body of work hath been devoted to the design and analysis of transformerless inverter topologies, which have supplanted conventional transformer-based systems due to their superior efficiency and reduced physical dimensions. Notwithstanding these advantages, the absence of galvanic isolation hath introduced the persistent issue of leakage current. In this regard, several scholars have proposed novel inverter configurations to mitigate such undesirable effects. For instance, common-grounded and multilevel inverter designs have been shown to significantly reduce leakage current by stabilising the common-mode voltage [2]. These approaches not only enhance safety but also improve overall system performance.

Further contributions in this domain have explored modified switching strategies and circuit configurations aimed at minimising leakage current whilst maintaining high efficiency. Certain studies have demonstrated that optimised modulation techniques can effectively suppress common-mode

voltage fluctuations, thereby reducing leakage currents without necessitating additional hardware components [3]. Such findings underscore the importance of intelligent control over switching operations in achieving improved inverter performance. Comprehensive reviews of transformerless inverter architectures have categorised various topologies based on their structural and operational characteristics. These analyses have highlighted the trade-offs inherent in different designs, such as the balance between efficiency, component count, and leakage current suppression [4]. It hath been observed that whilst certain topologies excel in reducing leakage current, they may introduce increased conduction losses or control complexity, thereby necessitating careful design considerations.

In addition to structural innovations, researchers have investigated advanced control methodologies to further enhance inverter performance. Techniques involving capacitor voltage balancing and real-time control have been proposed to stabilise inverter operation and reduce common-mode voltage variations [5]. Such strategies have proven effective in multilevel inverter systems, wherein precise control of voltage levels is essential for optimal performance. The foundational works on transformerless inverters have also contributed significantly to the understanding of their operational principles. Early studies introduced efficient switching schemes and unipolar modulation techniques, which laid the groundwork for subsequent advancements in inverter design [6]. These pioneering efforts demonstrated that high efficiency and reduced harmonic distortion could be achieved through appropriate modulation strategies.

Moreover, the elimination of ground leakage current through active decoupling techniques hath been extensively examined. By strategically controlling the switching states, researchers have succeeded in interrupting the leakage current path, thereby enhancing system safety and compliance with regulatory standards [7]. Such methods have been widely adopted in modern inverter designs due to their effectiveness and simplicity. Recent investigations have further refined these approaches by introducing advanced modulation strategies for cascaded and multilevel inverter configurations. These techniques aim to optimise switching transitions and minimise voltage stress across components, thereby improving efficiency and reducing harmonic distortion [8]. Comparative analyses have indicated that such topologies outperform traditional inverter designs in both leakage current suppression and power quality enhancement. Additionally, innovative single-stage inverter systems capable of both voltage boosting and leakage current limitation have been proposed. These designs eliminate the need for separate DC–DC converters, thereby simplifying the system architecture whilst maintaining high efficiency and safety standards [9]. Such advancements represent a significant step towards compact and cost-effective PV inverter solutions.

The adherence to established safety standards and grid codes remains a critical consideration in inverter design. Regulatory frameworks specify permissible limits for leakage current, harmonic distortion, and disconnection times, thereby guiding the development of compliant systems [10]. Researchers have thus endeavoured to design inverter topologies that not only achieve high performance but also satisfy stringent safety requirements. In the realm of control strategies, conventional proportional–integral–derivative (PID) controllers have been widely utilised due to their simplicity and ease of implementation. However, numerous studies have identified their limitations in handling nonlinear and time-varying systems [11]. These shortcomings have prompted the exploration of more advanced control techniques capable of delivering improved performance under diverse operating conditions.

Model predictive control (MPC) hath emerged as a promising alternative, offering fast dynamic response and precise control over system variables. Several investigations have demonstrated the efficacy of MPC in regulating inverter output and reducing harmonic distortion [12]. Nevertheless, the computational complexity associated with MPC may pose challenges in real-time implementation. Sliding mode control and other nonlinear control techniques have also been explored for their robustness and disturbance rejection capabilities. These methods have shown considerable promise in maintaining system stability under varying conditions, albeit at the expense of increased control complexity [13]. Consequently, the search for an optimal control strategy that balances performance and simplicity continueth. In this context, the Fractional Order PID (FOPID) controller hath gained prominence due to its enhanced flexibility and superior dynamic characteristics. By incorporating fractional calculus, the FOPID controller introduceth additional degrees of freedom, enabling more

precise tuning of system parameters [14]. This feature alloweth improved transient response, reduced overshoot, and enhanced robustness.

Numerous studies have demonstrated the advantages of FOPID controllers in power electronic applications, including improved tracking accuracy and reduced steady-state error [15]. Furthermore, their ability to handle system uncertainties and nonlinearities rendereth them particularly suitable for grid-connected PV systems [16]. Despite these merits, their application in transformerless inverter topologies remaineth relatively underexplored. The independent control of active and reactive power hath also been a subject of considerable interest. Researchers have proposed decoupled control architectures that enable simultaneous regulation of power components, thereby enhancing grid support capabilities [17]. Such approaches are essential for compliance with modern grid codes, which require distributed generation systems to contribute to voltage regulation and stability. The role of common-mode voltage stabilisation in leakage current reduction hath been extensively investigated. Techniques such as mid-point clamping and DC/AC decoupling have been shown to effectively minimise voltage fluctuations, thereby reducing leakage currents [18]. These methods, when integrated into inverter design, significantly enhance safety and performance. Furthermore, the importance of harmonic reduction and power quality improvement hath been widely acknowledged. Advanced modulation and control strategies have been developed to minimise total harmonic distortion (THD), thereby ensuring compliance with grid standards [19]. Such improvements are essential for the reliable operation of grid-connected PV systems.

Simulation and experimental validation have played a pivotal role in advancing inverter technology. Researchers have employed sophisticated modelling tools to analyse system behaviour under various conditions, including load variations and grid disturbances [20]. Experimental studies have further corroborated these findings, demonstrating the practical feasibility of proposed solutions. In recent years, the integration of intelligent control techniques, including artificial intelligence and optimisation algorithms, hath been explored to enhance system performance. These approaches offer the potential for adaptive control and real-time optimisation, thereby improving efficiency and reliability [21]. Nevertheless, their implementation in practical systems requireth further investigation. Hybrid inverter topologies, which combine multiple design principles, have also been proposed to address the limitations of existing systems. Such configurations aim to achieve a harmonious balance between efficiency, safety, and control flexibility [22]. Comparative studies have indicated that hybrid designs often outperform conventional topologies in multiple performance metrics. The increasing penetration of PV systems into the grid hath necessitated the development of inverters capable of providing ancillary services. These include reactive power support, voltage regulation, and fault ride-through capability [23]. Consequently, modern inverter designs must be versatile and adaptive to meet evolving grid requirements. Moreover, the reduction of electromagnetic interference (EMI) and enhancement of system reliability have been identified as key research areas. Advanced filtering techniques and robust design methodologies have been proposed to address these challenges [24]. Such efforts contribute to the long-term sustainability and reliability of PV systems. In conclusion, the extant literature revealeth a rich and diverse body of research dedicated to the advancement of transformerless PV inverter technology. Whilst significant progress hath been achieved in reducing leakage current and improving power quality, challenges remain in achieving optimal performance and grid compatibility [25]. The integration of advanced control strategies, such as the FOPID controller, with innovative inverter topologies presenteth a promising avenue for future research [26]. Thus, continued scholarly efforts are imperative to realise efficient, reliable, and grid-compliant PV systems [27]–[30].

### III METHODOLOGY

The methodological framework of the present study hath been devised with due consideration to both the structural configuration of the inverter system and the intricacies of advanced control mechanisms requisite for its efficient operation. At the outset, a hybrid transformerless single-phase photovoltaic inverter topology is conceived, wherein the principal objective is to mitigate leakage current whilst ensuring superior power quality and compliance with grid requirements. The architecture employeth a combination of decoupling techniques and mid-point clamping strategies, which collectively act to stabilise the common-mode voltage. By maintaining a constant potential across the parasitic

capacitances existing betwixt the photovoltaic array and the ground, the undesirable leakage current is significantly curtailed. The configuration further incorporateth multiple switching devices arranged in a manner that facilitateth both AC and DC decoupling, thereby enhancing operational safety and reducing voltage stress across the components. Subsequently, the operational behaviour of the inverter is delineated through a comprehensive analysis of its switching states under varying grid conditions. The system is designed to function effectively under both unity and non-unity power factor scenarios, thereby enabling the exchange of active as well as reactive power with the utility grid. During each cycle of operation, the inverter traverseth a sequence of modes characterised by the polarity of grid voltage and current, as well as the switching status of key semiconductor devices. Such an arrangement alloweth for precise regulation of power flow, whilst simultaneously ensuring that freewheeling paths are available during zero-voltage states to maintain continuity of current. The inclusion of mid-point clamping during these intervals further ensures that fluctuations in common-mode voltage are minimised, thereby contributing to the suppression of leakage current and enhancement of system stability.

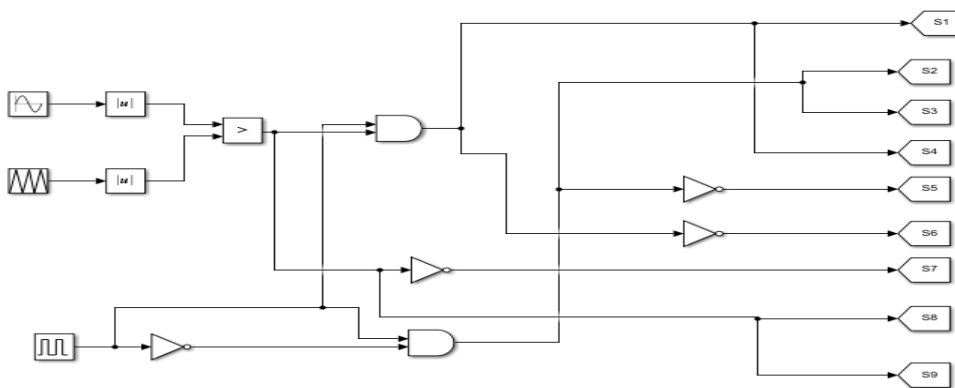

Fig 2. Modulation technique of the for open loop.

In order to achieve effective control over the inverter operation, a sophisticated control scheme is implemented, wherein the photovoltaic source is represented as a constant DC supply for the purposes of analysis. This simplification doth not detract from the realism of the model, as the high-frequency behaviour of the system rendereth the upstream converter dynamics negligible with respect to leakage current phenomena. The control architecture is devised to generate reference signals corresponding to the desired active and reactive power outputs, which are then utilised to regulate the inverter current injected into the grid. The transformation of measured electrical quantities into an appropriate reference frame facilitateth accurate computation of control variables, thereby enabling precise synchronisation with the grid voltage. Such synchronisation is of paramount importance in ensuring stable and efficient power transfer. The modulation strategy employed for the generation of switching pulses is of particular significance, as it directly influenceth the quality of the inverter output and the magnitude of harmonic distortion. A unipolar pulse-width modulation technique is adopted, wherein the switching devices are actuated in accordance with the instantaneous values of reference and carrier signals. The switching pattern is carefully orchestrated to ensure that decoupling mechanisms remain effective throughout the operation, particularly during transitions between active and freewheeling states. Certain switches operate continuously at high frequency, whilst others are modulated in accordance with the polarity of the grid voltage, thereby ensuring optimal utilisation of the inverter structure. This coordinated switching scheme not only enhances efficiency but also contributes to the reduction of switching losses and electromagnetic interference.

To further augment the dynamic performance and robustness of the system, a Fractional Order Proportional-Integral-Derivative controller is incorporated within the closed-loop control framework. Unlike conventional controllers, this approach introduceth fractional orders of integration and differentiation, thereby affording greater flexibility in tuning and improved adaptability to system nonlinearities. The controller continuously monitorith the deviation between the reference and actual output variables, generating corrective signals that ensure rapid convergence to the desired operating conditions. This results in improved transient response, reduced steady-state error, and enhanced disturbance rejection capability. The entire system is modelled and simulated within a MATLAB/Simulink environment, wherein its performance is evaluated under diverse operating scenarios, including variations in load and grid conditions. Through this comprehensive methodological approach, the proposed system demonstrateth its efficacy in achieving reduced leakage current, improved power quality, and reliable grid integration.

#### IV PROPOSED SYSTEM

The operation of the proposed system is founded upon the seamless integration of a photovoltaic energy source with a hybrid transformerless single-phase inverter, designed to deliver electrical power to the utility grid with enhanced safety and performance. The photovoltaic array generateth direct current electricity in response to solar irradiation, which is subsequently supplied to the inverter through a DC link arrangement comprising capacitors connected in series. These capacitors serve to stabilise the input voltage and provide a balanced midpoint potential, which is essential for the proper functioning of the inverter topology. The absence of a transformer rendereth the system more efficient and compact; however, it necessitates the incorporation of specialised techniques to mitigate leakage current. The proposed configuration addresseth this concern by maintaining a nearly constant common-mode voltage, thereby preventing the formation of undesirable current paths between the photovoltaic array and ground.

The inverter circuit operateth through a coordinated sequence of switching actions executed by multiple semiconductor devices arranged to facilitate both power conversion and decoupling. During the positive half-cycle of the grid voltage, certain switches conduct in such a manner as to allow the flow of current from the DC link to the grid, thereby delivering active power. Conversely, during the negative half-cycle, the switching pattern is altered to reverse the direction of current flow, ensuring a sinusoidal output consistent with grid requirements. In addition to active power transfer, the inverter is capable of supplying or absorbing reactive power by controlling the phase relationship between voltage and current. This is achieved by appropriately adjusting the switching states, which enable the current waveform to either lead or lag the grid voltage. Such functionality is indispensable for voltage regulation and grid stability in modern power systems.

A salient feature of the proposed system is the implementation of decoupling techniques that operate during both active and freewheeling intervals. When the inverter output voltage approaches zero, specific switches are activated to isolate the photovoltaic array from the grid, thereby preventing fluctuations in common-mode voltage. Simultaneously, alternative current paths are established to allow the continuation of current flow through passive components such as inductors and capacitors. This arrangement not only preserveth the continuity of operation but also reduceth switching stress and losses. Furthermore, the mid-point clamping mechanism is engaged during these intervals to stabilise the potential at the midpoint of the DC link capacitors. By maintaining a constant reference potential, the system effectivly suppresseth variations in common-mode voltage, which in turn minimiseth leakage current and enhances overall safety.

The control of the inverter is accomplished through an advanced closed-loop scheme, wherein the desired output current is generated based on reference values corresponding to active and reactive power demands. The system continuously measureth the grid voltage and current, and these signals are processed to derive the necessary control parameters. A synchronisation mechanism ensureth that the inverter output remaineth in phase with the grid voltage, thereby facilitating efficient power transfer. The control algorithm determineth the optimal switching states required to produce the desired current waveform, taking into account system constraints and operating conditions. By employing such a

strategy, the inverter is capable of maintaining high-quality output with minimal harmonic distortion, even in the presence of disturbances such as load variations or fluctuations in solar input.

To enhance the dynamic response and robustness of the system, a Fractional Order Proportional-Integral-Derivative controller is incorporated within the control loop. This controller extendeth the capabilities of conventional control methods by introducing fractional orders of integration and differentiation, thereby allowing finer adjustment of system dynamics. As the system operateth, the controller continuously evaluateth the error between the reference and actual output, generating corrective signals that guide the inverter towards the desired state. This results in improved transient performance, faster response to changes in operating conditions, and reduced steady-state error. The overall system is evaluated through detailed simulation, wherein its behaviour is observed under various scenarios, including changes in power demand and grid conditions. The results demonstrateth that the proposed system achievet h superior performance in terms of leakage current reduction, power quality improvement, and reliable grid integration, thereby affirming its suitability for modern photovoltaic applications.

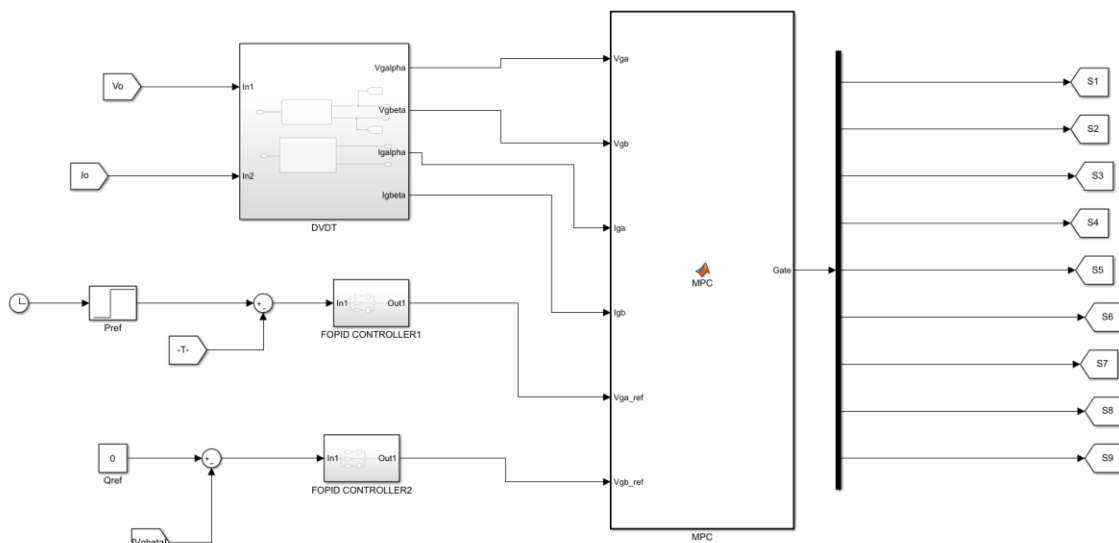

FIGURE 3 Control scheme for the proposed MPC topology with FOPID controller

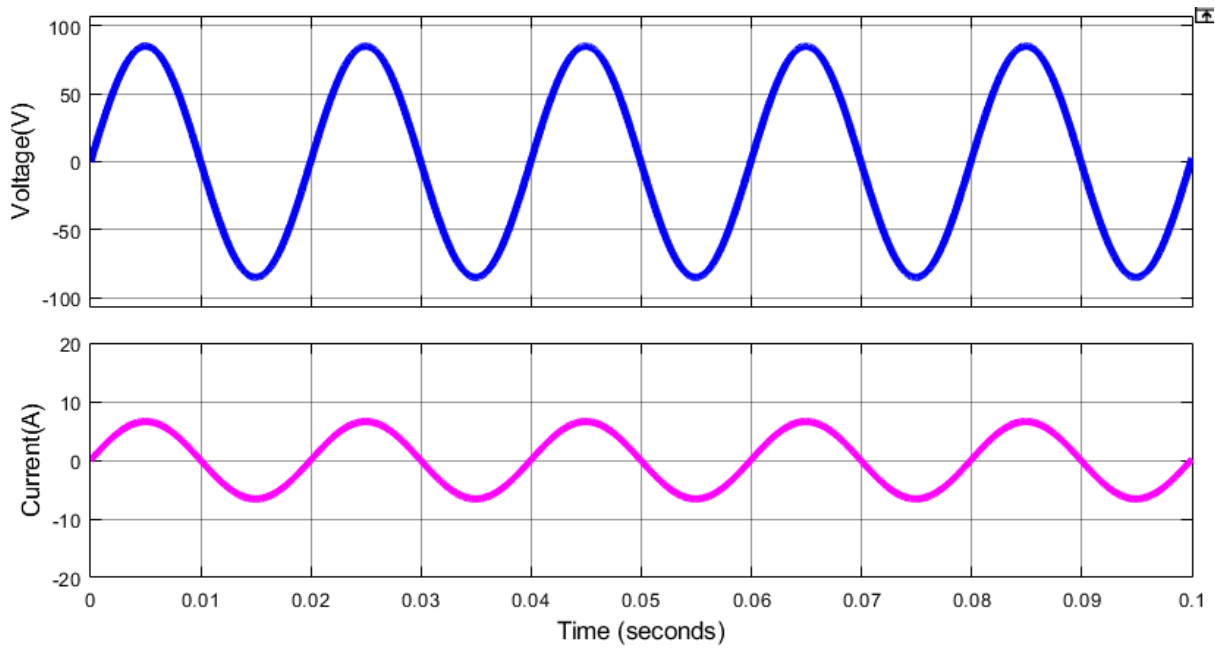

FIGURE 4. Simulation results of static performance with maximum instantaneous P of 660W.

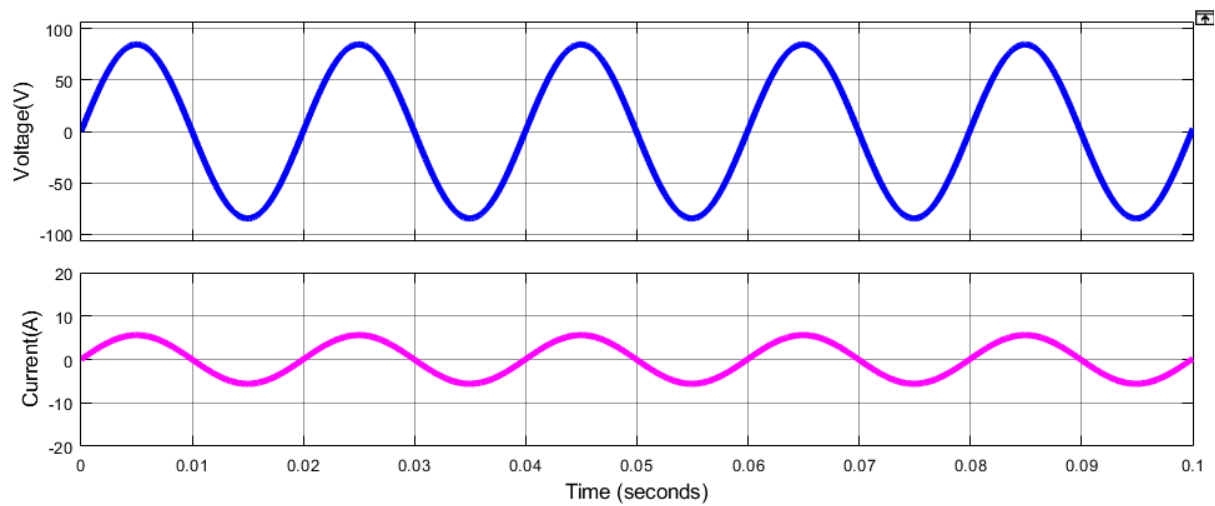

FIGURE 5. Simulation results of static performance with maximum instantaneous P and Q of (560W+j220VAR).

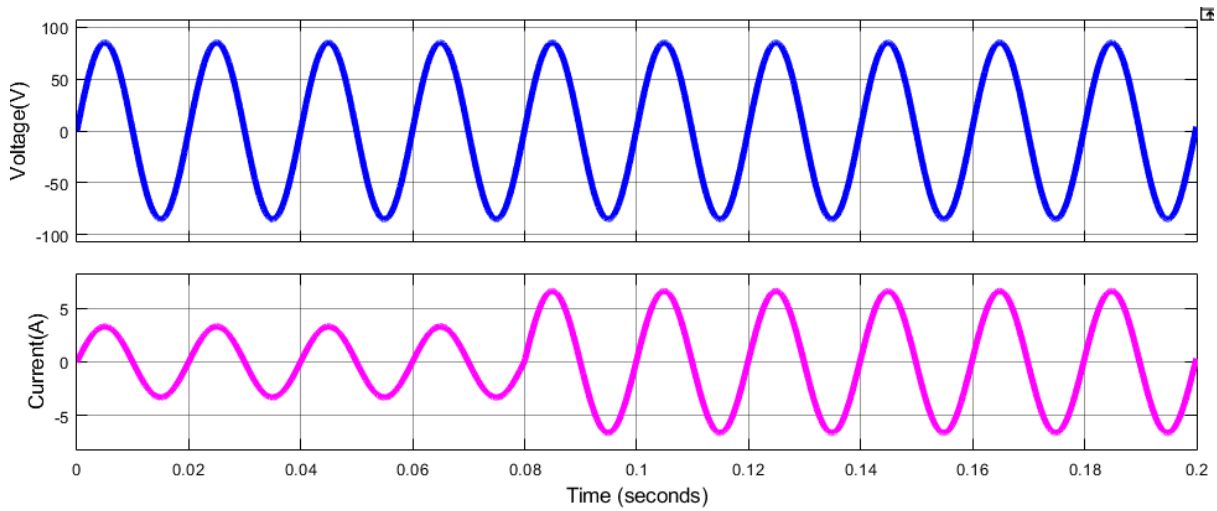

FIGURE 6. Simulation results of dynamic performance with maximum instantaneous P changing from 330W to 660W.

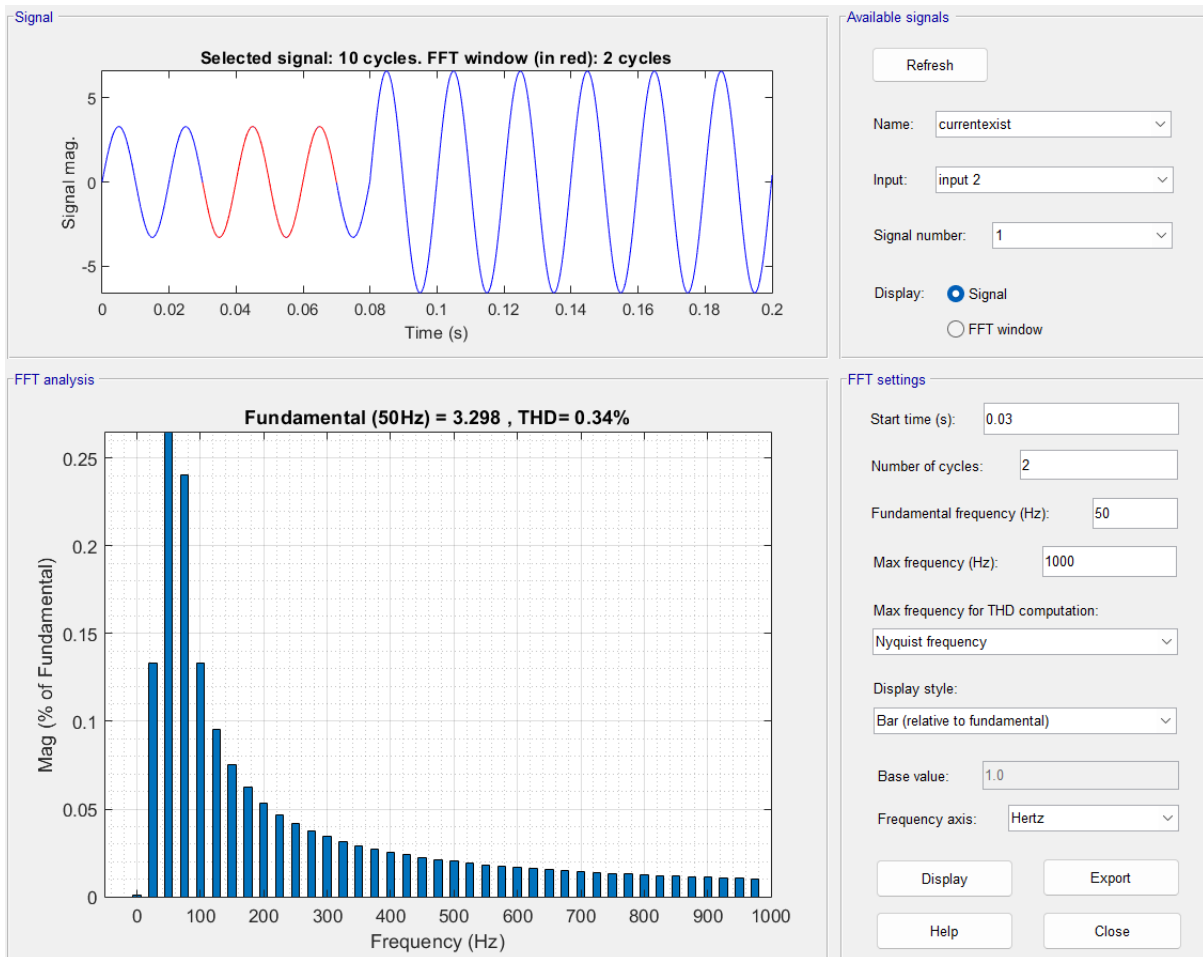

FIGURE 7 THD% of Grid current

**V CONCLUSION**

In conclusion, the proposed hybrid transformerless single-phase grid-connected photovoltaic (PV) inverter integrated with a Fractional Order Proportional–Integral–Derivative (FOPID) controller demonstrates significant improvements in system performance, safety, and grid compatibility. The implementation of decoupling techniques combined with mid-point clamping effectively stabilizes the common-mode voltage, leading to a substantial reduction in leakage current. This enhancement not only improves operational safety but also ensures compliance with established electrical standards. Moreover, the use of the FOPID controller provides superior dynamic performance, enhanced tracking accuracy, and improved robustness under varying operating conditions compared to conventional control methods. The system is capable of independently controlling active and reactive power, thereby supporting grid voltage regulation and contributing to overall system stability—key requirements for modern distributed generation systems. Simulation results confirm that the proposed inverter achieves improved output waveform quality with reduced total harmonic distortion (THD) and faster transient response. Additionally, the elimination of bulky transformers results in a more compact, efficient, and cost-effective design. Overall, the proposed system offers a reliable and advanced solution for next-generation grid-connected PV applications, effectively addressing both performance and safety challenges while meeting evolving grid requirements.

## REFERENCES

1. Islam, M., & Mekhilef, S. (2014). Improved transformerless PV inverter. *Energy Conversion and Management*, 88, 854–862.
2. Araujo, S. V., Zacharias, P., & Mallwitz, R. (2010). Highly efficient transformerless inverters. *IEEE Transactions on Industrial Electronics*, 57(9), 3118–3128.
3. López, Ó., Freijedo, F. D., Yepes, A. G., et al. (2010). Eliminating ground current in PV systems. *IEEE Transactions on Energy Conversion*, 25(1), 140–147.
4. VDE. (2006). Grid interconnection standards VDE-0126-1-1.
5. Ogata, K. (2010). *Modern control engineering* (5th ed.). Prentice Hall.
6. Camacho, E. F., & Bordons, C. (2007). *Model predictive control*. Springer.
7. Utkin, V. (1992). *Sliding mode control in engineering*. CRC Press.
8. Podlubny, I. (1999). *Fractional differential equations*. Academic Press.
9. Monje, C. A., Chen, Y., Vinagre, B. M., et al. (2010). *Fractional-order systems and controls*. Springer.
10. Das, S. (2011). *Functional fractional calculus*. Springer.
11. Teodorescu, R., Liserre, M., & Rodríguez, P. (2011). *Grid converters for PV systems*. Wiley.
12. Blaabjerg, F., Teodorescu, R., Liserre, M., & Timbus, A. V. (2006). Overview of grid converters. *IEEE Transactions on Industrial Electronics*, 53(5), 1398–1409.
13. Carrasco, J. M., Franquelo, L. G., Bialasiewicz, J. T., et al. (2006). Power-electronic systems for renewable energy. *IEEE Transactions on Industrial Electronics*, 53(4), 1002–1016.
14. Erickson, R. W., & Maksimovic, D. (2001). *Fundamentals of power electronics*. Springer.
15. Mohan, N., Undeland, T. M., & Robbins, W. P. (2003). *Power electronics*. Wiley.
16. Rashid, M. H. (2014). *Power electronics handbook*. Elsevier.
17. Bollen, M. H. J. (2000). *Understanding power quality problems*. IEEE Press.
18. Liserre, M., Teodorescu, R., & Blaabjerg, F. (2006). Stability of grid converters. *IEEE Transactions on Industry Applications*, 42(5), 1142–1152.
19. Guerrero, J. M., Vasquez, J. C., Matas, J., et al. (2011). Hierarchical control of microgrids. *IEEE Transactions on Industrial Electronics*, 58(1), 158–172.
20. Krohn, S., Morthorst, P. E., & Awerbuch, S. (2009). *Wind energy economics*.

21. Hassaine, L., Olias, E., Quintero, J., & Salas, V. (2014). Overview of power inverter topologies and control structures for grid-connected photovoltaic systems. *Renewable and Sustainable Energy Reviews*, 30, 796–807.
22. Kjaer, S. B., Pedersen, J. K., & Blaabjerg, F. (2005). A review of single-phase grid-connected inverters for photovoltaic modules. *IEEE Transactions on Industry Applications*, 41(5), 1292–1306.
23. Villanueva, E., Correa, P., Rodríguez, J., & Pacas, M. (2009). Control of a single-phase cascaded H-bridge multilevel inverter for grid-connected photovoltaic systems. *IEEE Transactions on Industrial Electronics*, 56(11), 4399–4406.
24. Teodorescu, R., Liserre, M., & Rodríguez, P. (2006). *Grid converters for photovoltaic and wind power systems*. Wiley.
25. Blaabjerg, F., Chen, Z., & Kjaer, S. B. (2004). Power electronics as efficient interface in dispersed power generation systems. *IEEE Transactions on Power Electronics*, 19(5), 1184–1194.
26. Yang, B., Li, W., Gu, Y., Cui, W., & He, X. (2012). Improved transformerless inverter with common-mode leakage current elimination. *IEEE Transactions on Industrial Electronics*, 59(1), 444–452.
27. Hu, H., Harb, S., Kutkut, N., Shen, Z. J., & Batarseh, I. (2013). A review of power decoupling techniques for microinverters. *IEEE Transactions on Power Electronics*, 28(11), 5161–5176.
28. Golestan, S., Guerrero, J. M., & Vasquez, J. C. (2013). Single-phase PLLs: A review of recent advances. *IEEE Transactions on Power Electronics*, 28(10), 4639–4653.
29. He, J., & Li, Y. W. (2011). Generalized closed-loop control schemes with embedded virtual impedances for voltage source converters. *IEEE Transactions on Power Electronics*, 27(4), 1850–1861.
30. Zhong, Q. C., & Hornik, T. (2013). *Control of power inverters in renewable energy and smart grid integration*. Wiley.