

International Journal of
Engineering Research and Science & Technology



ISSN : 2319-5991

www.ijerst.com

Email: editor@ijerst.com or editor.ijerst@gmail.com

IOT BASED COAL MINE SAFETY ROBOT WITH CASUALTY DETECTION AND FIRST AID KIT SUPPLY

**Mrs.K.BHARGAVI¹, M.TEJASWINI², G.SRIHITHA REDDY³, M.ROHITH⁴,
K.ABHI KASHYAP⁵**

¹Assistant Professor , Department of Electronics and Communication Engineering, TEEGALA
KRISHNA REDDY ENGINEERING COLLEGE, Meerpet , Hyderabad , 500097

^{2,3,4,5}UG Students, Department of Electronics and Communication Engineering, TEEGALA KRISHNA
REDDY ENGINEERING COLLEGE, Meerpet , Hyderabad , 500097

ABSTRACT

The "IoT-Based Coal Mine Safety Robot with Casualty Detection and First Aid Kit Supply" project represents a significant leap forward in the realm of mining safety and emergency response. Leveraging NodeMCU, fire sensors, gas sensors, DHT sensors, cameras, and web servers, this system offers a comprehensive solution for ensuring the safety of coal mine workers.

Coal mining is an essential industry, but it is fraught with inherent dangers, including fires, gas leaks, and health risks. This project addresses these concerns by employing advanced technology to safeguard miners' lives. The safety robot, equipped with a range of sensors, navigates the coal mine environment. Fire and gas sensors continuously monitor for hazardous conditions, while DHT sensors track temperature and humidity levels. In the event of a fire outbreak or gas leak, the robot can quickly detect and respond to mitigate the danger.

In addition to its safety features, the robot is equipped with a camera for real-time video feed. This allows remote operators to assess the situation and make informed decisions. In the unfortunate event of a casualty, the robot can carry and deploy a first aid kit to provide immediate assistance. Furthermore, the system incorporates a web server that enables remote monitoring and control. This web interface facilitates real-time tracking of environmental conditions, robot movements, and casualty detection, empowering mine operators to respond promptly to any emergency.

The "IoT-Based Coal Mine Safety Robot with Casualty Detection and First Aid Kit Supply" project underscores the pivotal role of IoT and automation in enhancing worker safety in hazardous environments. By providing real-time monitoring and immediate response capabilities, it significantly reduces the risks associated with coal mining operations.

Along with all casual detections of coal mine environment this robot also acts as Rescue robot serve as extensions of responders into a disaster which lifts up the person who gets injured

which works using servo motors. Servo motors accurately control the speed, position and its rotational. One more additional sensor is Vibration sensor which detects the vibrations in case of any rock bursts, roof distress and earthquakes of environment. This project aligns with the growing demand for advanced safety solutions in the mining industry and exemplifies the power of technology in saving lives.

INTRODUCTION

In the context of IoT-based robots, connectivity is the linchpin that empowers these machines to gather and transmit data in real-time. Through a network of interconnected devices, these robots can communicate with each other, cloud platforms, and even with humans. This connectivity enhances their ability to perform tasks autonomously and respond dynamically to changing conditions.

Sensors play a pivotal role in the functionality of IoT-based robots. These sensors, ranging from cameras and accelerometers to temperature and proximity sensors, allow the robots to perceive their environment accurately. By collecting data on various parameters, these robots can make informed decisions, navigate complex terrains, and adapt to diverse scenarios. For example, a surveillance robot equipped with IoT capabilities can transmit live video feeds to a central control unit, providing real-time monitoring of a targeted area.

Furthermore, the data generated by IoT-based robots can be leveraged for analytics and optimization. This data-driven approach not only enhances the capabilities of individual robots but also contributes to the collective intelligence of a network of interconnected robotic systems.

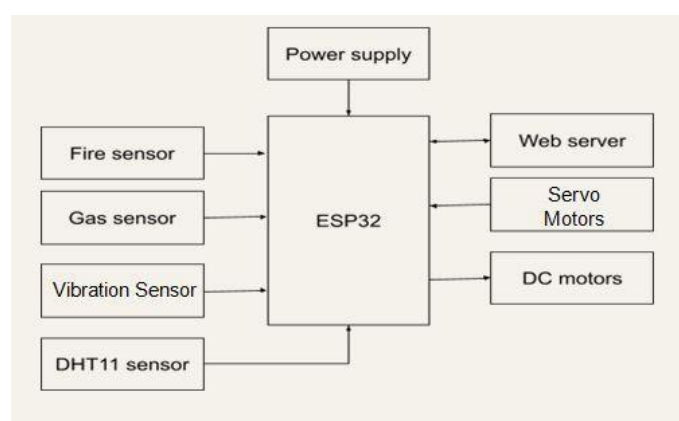

Figure.1 Block Diagram

OBJECTIVE OF THE PROJECT

The primary objective of this project is to mitigate the risks associated in mining industry. Coal mining is an essential industry, but it is fraught with inherent dangers, including fires, gas

leaks, and health risks. It represents a significant leap forward in the realm of mining safety and emergency response. This project addresses these concerns by employing advanced technology to safeguard miners' lives.

LITERATURE SURVEY

Search Academic Databases: Utilize academic databases like IEEE Xplore, Google Scholar, Scopus, and ACM Digital Library. Use Boolean operators (AND, OR) to combine your keywords effectively. For example, "IoT AND coal mine safety AND robot."

Review Recent Publications: Focus on recent publications (last 5-10 years) to ensure you're accessing the most up-to-date research in the field. Pay attention to articles that have been cited frequently, as they often represent seminal works.

Check Journals and Conferences: Look for articles in relevant journals (e.g., IEEE Transactions on Industrial Informatics, Robotics and Automation Letters) and conference proceedings (e.g., IEEE International Conference on Robotics and Automation, International Conference on Industrial Internet of Things).

Browse Theses and Dissertations: Explore theses and dissertations from universities worldwide. Search for terms like "coal mine safety," "robotics," "casualty detection," etc., in online repositories like ProQuest Dissertations & Theses Global or institutional repositories of universities.

Review Technical Reports and Whitepapers: Check technical reports and whitepapers published by robotics companies, mining industry organizations, and research institutions. Websites like arXiv and ResearchGate can be useful for accessing preprints and technical documents.

The proposed system for the IoT-based Coal Mine Safety Robot with Casualty Detection and First Aid Kit Supply embodies an integrated approach to revolutionizing safety measures in coal mining environments. This innovative system leverages IoT, robotics, and advanced sensor technologies to proactively monitor, identify potential hazards, detect casualties, and provide timely first aid support within coal mining operations. The following is an overview of the key components and functionalities of the proposed system:

IoT-enabled Monitoring and Data Analysis the system entails the deployment of IoT sensors throughout the coal mine environment to continuously monitor crucial parameters such as air quality, temperature, gas levels, and structural integrity. These sensors are interconnected through a robust IoT infrastructure, facilitating real-time data transmission and analysis. The collected data serves as the foundation for predictive analytics, enabling the system to

anticipate and mitigate potential safety risks.

Robust Robotics Platform central to the system is a highly capable robotic platform equipped with advanced mobility, navigation, and sensing capabilities. The robot is designed to traverse challenging terrains inherent to coal mining sites, utilizing ruggedized tracks or wheels for enhanced mobility. It integrates a suite of sensors including LiDAR, cameras, and gas detectors to efficiently map its surroundings, identify potential hazards, and respond to anomalies.

Hazard Detection and Intervention the system features sophisticated algorithms for hazard detection, enabling the robotic platform to identify gas leaks, unstable structures, or other safety threats within the mine environment. Upon detecting a hazard, the robot promptly alerts the control center and initiates appropriate response protocols, which may involve isolation of the affected area or the execution of predefined safety procedures.

Casualty Detection and Assistance in the event of a mining-related accident, the system employs advanced computer vision and AI-based algorithms to detect casualties. Upon identifying a person in distress, the robot autonomously navigates to the location, assesses the situation, and communicates the pertinent information to the control center. This seamless coordination expedites the deployment of rescue personnel and facilitates timely medical intervention.

RESULTS

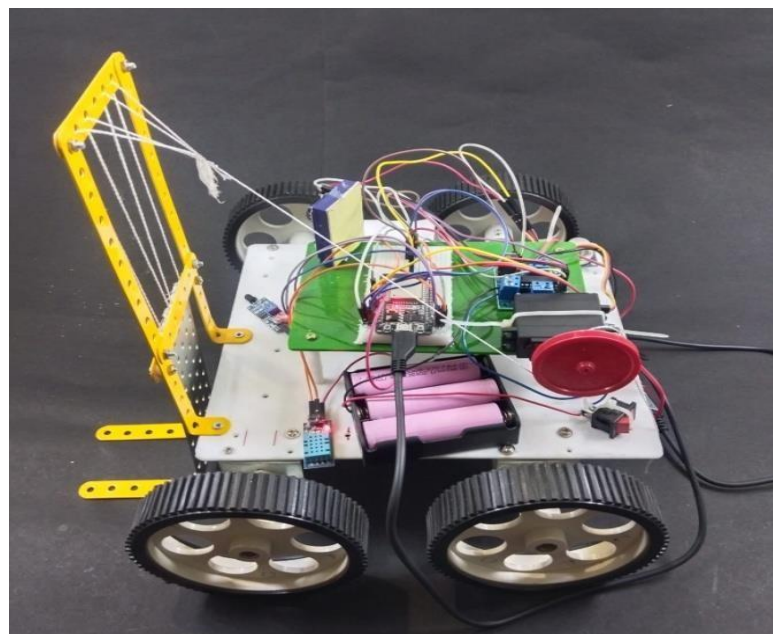

Figure.2 Practical device

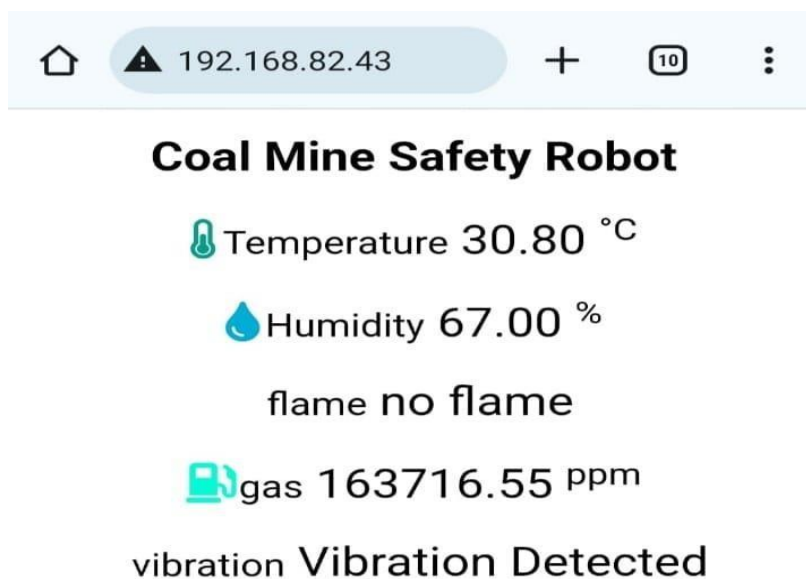

Figure.3 Detected Sensor Outputs

ADVANTAGES

- Enhanced Safety
- Timely Response to Hazards
- Improved Casualty Detection
- Real-time Monitoring and Control
- Integration with Existing Infrastructure
- Operational Efficiency

APPLICATIONS

- Hazard Detection and Monitoring
- Casualty Detection and First Aid Provision
- Emergency Response and Coordination
- Remote Monitoring and Management
- Compliance and Reporting
- Training and simulation
- Infrastructure Inspection and Maintenance
- Data Analytics for Safety Optimization
- Integration with Mine Safety Systems

CONCLUSION

In conclusion, the IoT-based Coal Mine Safety Robot with Casualty Detection and First Aid Kit Supply represents a groundbreaking innovation with the potential to significantly enhance safety and risk management within coal mining operations. By integrating IoT, robotics, and advanced sensor technologies, the system offers a comprehensive suite of capabilities that address critical safety challenges in the mining industry. The system's applications extend from hazard detection and emergency response to regulatory compliance and infrastructure maintenance, positioning it as a versatile and indispensable tool for ensuring the well-being of mining personnel and the efficiency of mining operations.

Through its real-time monitoring, casualty detection, and first aid support capabilities, the system contributes to a proactive and responsive approach to safety management. This proactive posture helps mitigate risks, minimize the impact of safety incidents, and optimize the overall safety infrastructure of coal mines. Furthermore, the system's potential for remote monitoring and data analytics empowers mine operators with valuable insights to continuously improve safety protocols and regulatory compliance.

The collaborative potential of the system in conjunction with emergency services further underscores its role as a vital component of integrated safety management. By facilitating seamless collaboration and providing crucial data to external emergency responders, the system contributes to streamlined and effective emergency responses in the event of a safety incident. Ultimately, the IoT-based Coal Mine Safety Robot with Casualty Detection and First Aid Kit Supply sets a new standard for safety innovation in coal mining, promising to redefine safety protocols, reduce risks, and uphold the well-being of mining personnel. As the mining industry continues to prioritize safety and operational excellence, this advanced system stands poised to play an instrumental role in elevating safety standards and transforming safety management practices within coal mining operations.

FUTURE SCOPE

Enhanced Sensor Integration: Continuous advancement in sensor technology, such as the integration of cutting-edge environmental sensors, biometric sensors, and advanced imaging technology, can further enhance the system's capability to detect hazards, monitor environmental conditions, and assess the well-being of the personnel in real time.

Artificial Intelligence and Machine Learning: Incorporating AI and machine learning algorithms can enable the system to learn from past incidents, predict potential hazards, and

optimize its response strategies. This can lead to a more proactive and adaptive safety system that continuously evolves to improve its performance.

Autonomous Navigation and Mapping: Future iterations of the system can focus on developing advanced autonomous navigation capabilities, including 3D mapping of mine environments, obstacle avoidance, and efficient path planning to further enhance the robot's mobility and operational efficiency.

Integration with Mine Management Systems: Seamlessly integrating the safety robot with existing mine management systems, such as production monitoring, resource allocation, and scheduling, can lead to enhanced coordination and synergy between safety operations and overall mine management, thereby optimizing productivity and safety simultaneously.

Remote Operation and Virtual Reality: Exploring the potential for remote operation using virtual reality interfaces can provide an opportunity for safety personnel to oversee and control the safety robot from a central command center, enabling rapid response to safety incidents and providing real-time support to on-site personnel.

REFERENCES

- [1]. Yongping Wu and Guo Feng, "The study on coal mine monitoring using the Bluetooth wireless transmission system" , 2014 IEEE Workshop on Electronics, Computer and Applications, pp. 1016-1018, 2014.
- [2]. Xiaolong Feng, Jiansheng Qian, Zhenzhen Sun, Xing Wang, "Wireless Mobile Monitoring System for Tram Rail Transport in Underground Coal Mine Based on WMN," Conference on Computational Aspects of Social Networks, 2010.
- [3]. Yi-ming Tian, You-rui Huang, Yi-qing Huang, "Intelligent Information Processing of WSN Based on Vague Sets Theory and Applied in Control of Coal Mine Monitoring," cccm, vol. 2, pp.649-652, 2008 ISECS International Colloquium on Computing, Communication, Control, and Management, 2008.
- [4]. Jingjiang Song ,Yingli Zhu and Fuzhou DongK, "automatic monitoring system for coal mine safety based on wireless sensor network", IEEE Radio Science and Wireless Technology Conference, pp.933-936, 2011.
- [5]. Yogendra S Dohare and Tanmoy Maity, "surveillance and safety system for underground coal mines based on Low Power WSN", IEEE, pp.116-119, 2014.
- [6]. Valdo Henriques and Reza Malekian, " Mine safety system using wireless sensor network", IEEE, pp. 1-12, 2016.

- [7]. Huping Xu, Feng Li, Yancheng Ma, A ZigBee-based miner Localization System', IEEE, 2012. 8 Shuo pang, Ricardo Trujillo, Indoor Localization Using Ultrasonic Time Difference of Arrival', IEEE, 2013.
- [8]. Yongping Wu, Guo Feng, Zhang Meng, The Study on Coal Mine Using the Bluetooth Wireless Transmission', IEEE, 2014.