

International Journal of
Engineering Research and Science & Technology



ISSN : 2319-5991

www.ijerst.com

Email: editor@ijerst.com or editor.ijerst@gmail.com

SMART CARGO MONITORING SYSTEM

1. DR. SMP SAMY, 2. SAI DIVYA, 3. PRATHUSHA, 4. PRACHI

1. PROFESSOR, 2, 3 & 4. UG SCHOLAR

DEPARTMENT OF ECE, MALLA REDDY ENGINEERING COLLEGE FOR WOMEN,
HYDERABAD

ABSTRACT In the dynamic landscape of cargo transportation and logistics, ensuring the safety and efficiency of cargo loading operations is paramount. One critical aspect of this is cargo load monitoring, where the accurate measurement and management of cargo weight play a crucial role in maintaining transportation safety, compliance, and operational efficiency. The advent of innovative technologies has paved the way for Smart Cargo Load Monitoring Systems tailored for various industries. Unlike traditional cargo monitoring methods, smart solutions leverage advanced sensors, real-time data analytics, and interconnected networks to create a proactive and intelligent approach to cargo load measurement and management. The Smart Cargo Load Monitoring System represents a paradigm shift from conventional cargo weighing methods by integrating cutting-edge technologies, primarily Internet of Things (IoT) devices. These devices, such as load sensors, pressure sensors, and wireless communication modules, are strategically

deployed throughout cargo transport vehicles to form a comprehensive network capable of real-time monitoring. This network not only enables accurate measurement of cargo weight but also facilitates real-time feedback and adjustments to ensure optimal loading conditions.

INTRODUCTION: Smart Cargo Load Monitoring System include sensor arrays, data processing units, and interconnected communication channels. These components work together to collect and analyze data, allowing the system to provide accurate and real-time information about the cargo weight. The system can trigger automated alerts, such as warnings for exceeding weight limits or unbalanced loads, ensuring compliance with transportation regulations and enhancing overall safety. The integration of smart technologies extends beyond cargo weight measurement to include predictive capabilities. Through the analysis of historical data and patterns, Smart Cargo Load Monitoring Systems can anticipate

potential issues related to cargo load, enabling proactive measures to prevent incidents before they occur. This predictive capability not only enhances safety but also contributes to operational efficiency and resource optimization. The transportation industry, with its diverse and complex cargo loading scenarios, stands to benefit significantly from the implementation of Smart Cargo Load Monitoring Systems. These systems offer a tailored and adaptive approach to cargo load management, aligning with the unique challenges posed by various types of cargo and transportation modes. As the transportation sector embraces digital transformation, the convergence of IoT, data analytics, and cargo load monitoring presents a forward-thinking solution that not only ensures compliance but also elevates overall safety and efficiency standards in cargo transportation. In the subsequent sections, we delve into the specific components, functionalities, and advantages of Smart Cargo Load Monitoring Systems, highlighting their transformative impact on cargo transportation protocols. The implementation of a Smart Cargo Load Monitoring System goes beyond its immediate role in cargo weight measurement; it forms an integral part of broader transportation safety and efficiency

ecosystems. With interconnected devices and data-driven insights, these systems contribute to creating a holistic cargo monitoring infrastructure, aligning with industry standards and regulatory requirements. Central to the effectiveness of a Smart Cargo Load Monitoring System is its ability to provide real-time data analytics. The continuous monitoring of cargo weight, combined with advanced analytics, allows the system to detect subtle changes indicative of potential cargo load issues. By leveraging machine learning algorithms, the system can adapt and improve its accuracy over time, enhancing its predictive capabilities. Integration with Vehicle Fleet Management Systems and Transportation Management Systems (TMS) further extends the functionalities of Smart Cargo Load Monitoring. This integration enables seamless communication with other critical components of transportation operations, facilitating coordinated responses during loading, transit, and unloading processes, optimizing overall safety and efficiency protocols. One notable feature of Smart Cargo Load Monitoring Systems is their capacity for remote monitoring and control. Transportation vehicles, often covering vast distances, benefit from the ability to remotely access and manage cargo load

monitoring systems. This capability not only expedites response times but also enables proactive measures, such as remotely adjusting cargo loads to prevent potential transportation risks. Scalability is a key consideration for the transportation industry, with diverse cargo types, vehicle sizes, and evolving infrastructures. Smart Cargo Load Monitoring Systems are designed to be scalable, accommodating the expansion or modification of transportation fleets. This adaptability ensures that as transportation companies grow and evolve, their cargo load monitoring systems can seamlessly integrate with new technologies and accommodate changes in infrastructure. The economic impact of transportation incidents, such as overloading or unbalanced loads, is substantial, ranging from vehicle damage to safety hazards on the road. Smart Cargo Load Monitoring Systems contribute to cost savings by minimizing the risk of cargo-related incidents and reducing the associated financial implications. Moreover, compliance with weight regulations and safety standards further underscores the economic benefits of investing in advanced cargo load monitoring technologies.

LITERATURE SURVEY The literature survey for the proposed Smart Cargo Load

Monitoring System encompasses a thorough exploration of existing research, technologies, and methodologies related to advanced cargo monitoring in the transportation industry. This comprehensive survey aims to identify key trends, challenges, and innovations, providing a foundation for the development and implementation of the proposed system.

Cargo Load Monitoring Technologies:

The survey begins by examining various cargo load monitoring technologies currently employed in the transportation industry. Traditional methods, such as weighbridges and static scales, are contrasted with modern technologies, including load sensors, pressure sensors, and advanced weighing systems. Insights are gathered on the accuracy, reliability, and efficiency of these technologies, considering their applicability to different types of cargo and transportation modes.

Internet of Things (IoT) in Cargo

Monitoring: The integration of IoT devices in cargo monitoring systems is a key focus of the literature survey. Studies exploring the use of wireless communication modules, sensors, and IoT platforms for real-time data collection and analysis are

scrutinized. The benefits of an interconnected network in enhancing cargo load monitoring accuracy, responsiveness, and adaptability to dynamic transportation scenarios are thoroughly investigated.

Predictive Analytics for Cargo Load Management: The literature survey delves into research on predictive analytics applied to cargo load management. Machine learning algorithms and real-time data analytics are explored for their potential in anticipating and preventing cargo-related incidents. The survey aims to understand how historical data analysis contributes to the development of predictive models, offering insights into optimizing cargo loading conditions and ensuring compliance with weight regulations.

Integration with Transportation Management Systems (TMS): The role of Smart Cargo Load Monitoring Systems in integrating with Transportation Management Systems (TMS) is examined. Studies detailing the seamless communication between cargo monitoring systems and broader transportation management platforms, including route planning, scheduling, and fleet optimization, are investigated. This integration is crucial for ensuring a

coordinated and efficient transportation workflow.

Remote Monitoring and Control: The literature survey explores the significance of remote monitoring and control capabilities in cargo load monitoring systems. Case studies and research findings related to the remote access and management of cargo monitoring systems are scrutinized. The survey aims to identify how this feature contributes to timely responses, proactive adjustments, and enhanced safety in transportation operations.

Cybersecurity Measures in Cargo Monitoring Systems: Given the interconnected nature of Smart Cargo Load Monitoring Systems, the literature survey investigates cybersecurity measures implemented to safeguard these systems. Studies on encryption protocols, secure communication channels, and protection mechanisms against cyber threats are examined. Understanding how cargo monitoring systems mitigate vulnerabilities and ensure the integrity of data is crucial for successful implementation.

Energy-Efficient Technologies in Cargo Monitoring: The incorporation of energy-efficient technologies in Smart Cargo Load

Monitoring Systems is explored. Research on advanced propulsion systems, sustainable power sources, and eco-friendly materials used in cargo monitoring devices is scrutinized. The survey aims to identify how these technologies contribute to sustainable and responsible practices in cargo transportation.

Training Programs and User Awareness:

The literature survey addresses the human factor in the successful implementation of Smart Cargo Load Monitoring Systems. Studies on the development of comprehensive training programs for transportation personnel and initiatives to raise user awareness are examined. Insights into the effectiveness of these programs in ensuring proficient operation and collaboration with cargo monitoring systems are gathered.

Compliance with Regulations and Standards: Ensuring compliance with weight regulations and safety standards is a critical aspect of cargo load monitoring. The survey investigates studies detailing how Smart Cargo Load Monitoring Systems are designed to meet or exceed regulatory requirements. Regular audits and assessments are explored as integral components to verify ongoing compliance

with local, national, and international safety guidelines.

Continuous Improvement Framework:

The literature survey navigates through continuous improvement frameworks applied to cargo monitoring systems. Research on incorporating feedback from operational use, simulations, and real-world scenarios is examined. The survey aims to identify how these frameworks contribute to the dynamic evolution of cargo load monitoring technologies, ensuring they remain effective and responsive to emerging challenges.

In summary, the literature survey provides a comprehensive understanding of existing technologies, challenges, and innovations in the field of cargo load monitoring for transportation. The insights gathered will inform the development and implementation of the proposed Smart Cargo Load Monitoring System, ensuring it aligns with industry best practices and addresses current and future needs in cargo transportation safety and efficiency.

IMPLEMENTATION

Methodology

The development and implementation of the Smart Fire Management System follow

a structured methodology comprising several sequential stages to ensure a systematic and effective approach. The initial step involves clearly defining the system's objectives, emphasizing early detection, predictive analytics, and seamless communication, while concurrently identifying specific requirements such as multi-sensor networks, predictive analytics algorithms, and communication protocols. Subsequently, a comprehensive literature review is conducted, delving into existing technologies, challenges, and best practices within the realm of Smart Fire Management Systems. Relevant research papers, case studies, and technological advancements are identified to inform the subsequent conceptual design.

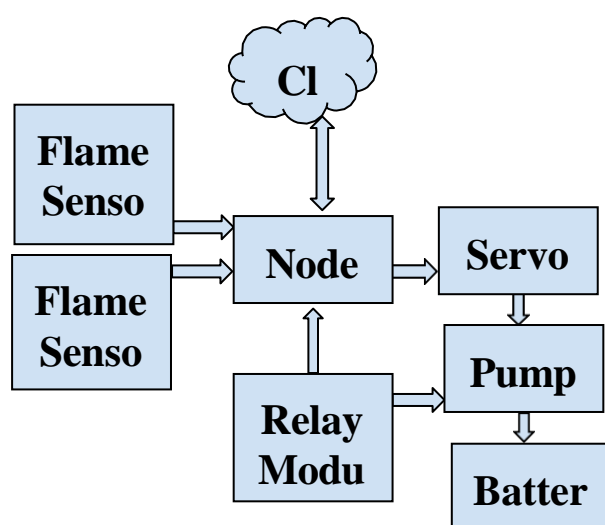

Figure 3.1: Block Diagram

The conceptual design phase encompasses the development of a comprehensive blueprint for the Smart Fire Management System, incorporating insights from the defined objectives and literature review findings. Specific considerations include the types of sensors to be integrated, the implementation of predictive analytics algorithms, and the overall architecture of the system.

The selection of IoT components and sensors follows, with a meticulous evaluation of factors such as reliability, accuracy, and compatibility. This includes the incorporation of sensors for smoke detection, heat sensing, flame detection, and environmental monitoring.

The integration of autonomous systems becomes a focal point, involving the implementation of advanced AI algorithms to facilitate autonomous navigation. This encompasses obstacle detection, path planning, and decision-making capabilities to enable the Smart Fire Management System to operate autonomously in dynamic industrial environments.

A robust communication infrastructure is designed and implemented using IoT technologies, emphasizing secure data transmission, communication protocol

exploration, and seamless connectivity with other critical components within industrial operations.

Cybersecurity measures are implemented to safeguard the Smart Fire Management System against potential cyber threats. This includes the integration of encryption protocols, secure authentication mechanisms, and regular updates to address emerging vulnerabilities.

The incorporation of energy-efficient technologies is a key consideration, optimizing overall energy consumption through the integration of advanced propulsion systems, sustainable power sources, and eco-friendly materials aligned with environmental sustainability goals.

A prototype of the Smart Fire Management System is developed based on the conceptual design, subject to rigorous testing and validation of integrated IoT systems, sensors, and autonomous navigation capabilities within controlled environments.

Simulations and controlled testing are conducted to evaluate system performance across various scenarios, encompassing navigation in diverse maritime environments, responses to simulated threats, and communication reliability.

The optimization and refinement phase follows, addressing any identified weaknesses or limitations through iterative improvements to the design and functionality based on feedback from simulations and testing.

Comprehensive training programs for military personnel are developed to ensure proficiency in operating and collaborating with the Smart Fire Management System. Emphasis is placed on familiarity with autonomous systems, IoT interfaces, and emergency procedures.

Ensuring regulatory compliance is paramount, with a focus on adherence to maritime laws, regulations, and ethical considerations. Legal and ethical implications associated with the deployment of autonomous systems in military operations are thoroughly addressed.

The deployment and evaluation phase involves real-world scenarios, closely monitoring system performance and collecting operational data to assess the effectiveness of IoT-enabled systems in achieving defined objectives.

The methodology concludes with the establishment of a continuous improvement framework. This involves regular updates

to software, addressing emerging threats, and incorporating advancements in IoT and autonomous technologies to enhance the capabilities of the Smart Fire Management System. This comprehensive methodology ensures a systematic and adaptive approach to the development and deployment of the proposed system, aligning with the overarching goals of enhancing industrial fire safety and operational efficiency.

CONCLUSION

In conclusion, the introduction of Smart Cargo Load Monitoring Systems marks a significant advancement in cargo transportation safety and efficiency. By leveraging IoT, data analytics, and real-time monitoring, these systems transcend traditional cargo weighing methods, providing a proactive, intelligent, and adaptive approach to safeguarding cargo during transportation. The subsequent exploration will delve deeper into the specific components, functionalities, and case studies, illustrating the transformative impact of Smart Cargo Load Monitoring Systems on cargo transportation safety and efficiency standards

REFERENCES

- Xiaoqin Lian, Yifang Weng, Xiaoli Zhang, Zhengang Duan, Yelan Wu,

“Material Automatic Management System Based on Smart Label Technique,” *Micro-computer Information*, vol. 22, no. 5-3, pp. 137-139, May 2006.

- Chao Zou, Chengyu Jiang, “The Applications of RFID Technology in Logistics Management and Constraints,” *Materials Science Forum*, vol. 532, pp. 1009-1011, 2007.
- Dalip. Vijay Kumar, “GPS and GSM based Passenger Tracking System”, *International Journal of Computer Applications (0975 8887) Volume 100--- No.2, August 2014*
- Abid Khan, Ravi Mishra, “GPS GSM based tracking system,” *International Journal of Engineering Trends and Technology*, Vol. 3, Issue 2, pp: 161-164, 2012.
- Ali Mousavi, Mohammad A. Rajabi, Mohammad Akbari, "Design and Implementation of a GSM Based Automatic Vehicle Location System[J]", *Computational Science and Its Applications ICCSA 2009*, pp. 533-542.

- Anwar. M.Raafay, Anwar. Osama, Shamim. Syed Faisal and Zahid.Ahmer Ali, “Human machine interface using OPC (OLE for process control),” Student Conference on Engineering Sciences and Technology, SCONEST, Pakistan, pp.35-40, Dec 2004.
- Matthew J.B. Robshaw. An overview of RFID tags and new cryptographic developments. Information Security Technical Report, Volume 11, Issue 2, 2006, Pages 82-88.
- Ahmed Ahmed, Elshaimaa Nada and Wafaa AlMutiri,” University Buses Routing and Tracking system”, International Journal of Computer Science & Information Technology (IJCSIT) Vol 9, No 1, February 2017.
- Guru.K, “ Innovative Approach of Game Theory in Strategic Business Operations International Journal of Research and Analytical Reviews, Vol 1: 126 131