



# International Journal of Engineering Research and Science & Technology

[www.ijerst.org](http://www.ijerst.org)

ISSN : 2319-5991

Vol. 21 No. 4 (2025)



[ijerst.editor@gmail.com](mailto:ijerst.editor@gmail.com)  
[editor@ijerst.com](mailto:editor@ijerst.com)

**Research Paper****PREDICTIVE CONTROL OF PMSG-BASED HYDRO-ELECTRIC SYSTEM WITH BATTERY SUPPORTED UPQC****Chocchupatla Siva Naga Raju<sup>1</sup>, Dr. B. Amarendra Reddy<sup>2</sup>***M. Tech Student, Department of electrical and electronics engineering, Andhra University, Waltair Junction, Visakhapatnam- 530003 (A.P)**Associate Professor, Department of electrical and electronics engineering, Andhra University, Waltair Junction, Visakhapatnam- 530003 (A.P)*

**Abstract** Issues with power pleasant (PQ) rise up whilst nonlinear and imbalanced loads are included with renewable energy resources, strength electronic gadgets, and different electricity assets. Because it improves device performance, cuts strength prices, guarantees non-stop deliver, and removes the need for ordinary maintenance, mitigating PQ issues inside the distribution machine is crucial for both providers and users. The freestanding hydro-electric powered gadget is ready with a unified power great conditioner (UPQC) that improves both the voltage and contemporary traits abruptly. A generator referred to as a hydro-driven everlasting magnet synchronous machine (PMSG) is powering a load that is mainly sensitive to nearby situations. To ensure that UPQC is being controlled efficiently, a predictive based control method is used to provide the important switching pulses. By utilizing a series injection transformer, this UPQC-based gadget improves the power first-class (PQ) of the weight voltages. This is accomplished by ensuring that the generated voltages hold sinusoidal waveforms and magnitudes regular with the preferred cost, even if the masses vary. In addition to ensuring that the PMSG stator currents are sinusoidal and without harmonics, the shunt compensator components the reactive electricity wished by using the device and compels the generator to run at cohesion energy thing, which reduces losses. This paper affords a MATLAB simulation of PMSG-based totally hydroelectric energy production with battery assistance and examines its performance underneath various situations. In addition, the prototype's efficacy in imparting excellent current and voltage in accordance with IEEE trendy 519 became confirmed by means of laboratory validation.

Received: 23-09-2025

Accepted: 25-10-2025

Published: 01-11-2025

**1. INTRODUCTION**

As a end result of the growing call for for strength on a international scale, conventional strength vegetation that rely upon coal or oil emit a amazing deal of pollutants. A part of the electric electricity furnished by using those traditional flowers is being replaced, little by means of bit, through producing stations based on locally to be had renewable electricity assets (RES) [1]. The benefits of renewable energy sources (RES) are their protection, low environmental effect, and ease of installation anywhere way to the usage of conveniently to be

had nearby assets and little in advance expenses. In comparison, the downsides are very sensitive to modifications in both the available capability and market situations. The capability to lessen distribution and transmission losses is just one of the many benefits of off-grid solutions which can be riding their growing popularity. Because of its compactness, reliability, economy, low weight, and brushless structure, which allows to decrease losses and maintenance charges, self-excited induction generators (SEIG) are first utilized in small hydro flowers (SHPs). It also promotes brief response in dynamic operation

and has smooth-to-apprehend controls. There are some downsides, but. I. It has bad voltage law. Ii. It calls for an additional setup for self-excitation in off-grid or standalone programs. Iii. It isn't suitable for packages with velocity versions during a broad variety of masses. The conditions for strolling an induction generator (IG) independently in self-started mode are: first, the rotor velocity must be maintained above synchronous speed; second, a pre-charged capacitor financial institution with the suitable rating should be connected across the stator terminals which will offer the required VAR.

This research takes a take a look at the overall performance of a everlasting magnet synchronous generator (PMSG) gadget beneath unique loading situations, mainly looking at its use in SHP programs. For a spread of pace applications with excessive energy factors (pf), PMSGs are an notable desire because of their efficiency [4,5]. The blessings of PMSG encompass its brushless layout, the fact that it does no longer experience any excitation loss, and the truth that it could deliver rated voltage without requiring an extra reactive strength supply. The use of PMSG for hydropower producing has received little attention. This work employs a PMSG to generate voltage, taking into account its advantages in terms of value, simplicity of voltage buildup, and the fact that it does no longer need external stimulation. Permanent magnet machines can also fail to provide the specified voltage at the specified pace while the load necessities or impedances change. The necessary power and the desired voltage significance aren't attaining the touchy or vital loads. Situations like this lead to a number of problems for crucial hundreds that want continuous, uninterrupted, distortion-loose voltages, such statistics centre servers, life assist gadget in hospitals, and so on. Therefore, it is essential to maintain a constant voltage at the load terminals. These voltages are outdoor the control of the unbiased RPG device that changed

into evaluated in [6]. Shunt voltage supply inverters (VSIs) allow for PQ development by means of regulating the importance of the generator voltage to its rated value. One disadvantage of using a shunt compensator to govern the significance of the generator voltage is that it attracts more reactive energy from the PMSG. Consequently, the pf on the terminals of the generator is decreased. By strolling the generator at a voltage that is 10 to twenty-five% decrease than its rated value and keeping the vital load voltages at their rated values the use of a sequence compensator, the system's performance may be progressed.

An technique to deal with voltage and modern-day high-quality concerns is explored on this have a look at via integrating a hydro electric producing gadget primarily based on PMSG with a unified power first-class conditioner (UPQC). Even everlasting magnet machines with modest magnetic strengths and no price voltage technology capability may additionally profit from this generation. Shunt VSI of UPQC reduces reactive energy taken from the supply, which improves pf at the generator terminals, whilst series VSI keeps the voltages on the critical load terminals consistent. One particular power device that addresses most of PQ's distribution device difficulties is a UPQC, that's built on electricity electronics. There are two VSIs running together at a unmarried DC point. The key challenges with UPQC are on the want for coordination between these two VSIs a good way to simultaneously cope with PQ problems. This can only be finished with a control algorithm that is both efficient and well-coordinated. In order to enhance the PQ of a 3-section distribution system, a synchronous reference frame (SRF) control is considered for UPQC integration.

However, their overall performance has declined and is becoming worse since the load modern-day waveform consists of harmonic additives, most people of which can be of the 0.33 order,

and their capacity to filter these components is pretty bad. In [14], we pass over the standard manipulate for DC UPQC based on dq theory, which uses a twin active bridge to growth the PQ of a freestanding system that makes use of a doubly fed induction generator. To growth the PQ of the distribution grid with a solar photovoltaic (SPV) included shunt compensator, techniques which include fuzzy logic manipulate (FLC) and least imply square (LMS) based totally on unit voltage template (UVT) controller are mentioned in [15].

This FLC is used to are expecting the voltage of the SPV array on the maximum energy factor (MPP). The DC-DC increase converter's gating pulses are produced through that MPP voltage. In addition, shunt compensators and shunt VSIs employ the LMS technique to generate gating pulses. Nevertheless, whilst running in a consistent kingdom, the control described in [15] performs poorly. These days, grid-related inverters and electric drives appoint model predictive controllers (MPCs) to modify the inverter's output current, the motor's torque and velocity, and other parameters. Because of its specific tracking, fast dynamic response, loss of tuning parameters, and independence from external kind modulators, state-of-the-art controllers like MPC are highlighted. Nonlinear hundreds motive cutting-edge harmonics, which the MPC technique in [16] can't get rid of.

**2. Design configuration and model description**

The described standalone gadget, shown in Fig. 1, consists of a PMSG because the AC supply and a battery backup for crucial load power. The masses under attention here are diode bridge rectifiers, which can be a common component of nonlinear hundreds. Rectifiers distort AC supply currents, making them look like rectangular or quasi-rectangular waves. By integrating a UPQC for PQs improvement at each the weight and generator ends, this standalone hydroelectric electricity production with PMSG and battery

backup system can also acquire higher PQs ordinary. Near the load give up, the shunt VSI is connected in parallel with an inductor at every phase of the VSI. The generator and cargo terminals are related in series with VSI the usage of an interface inductor and a series transformer. A immediately connected battery garage maintains a consistent voltage throughout UPQC at its DC factor. Shunt and series VSIs use passive RC filters to lessen voltage and modern-day ripples. The Appendix includes the listing of the selected values and the design standards.

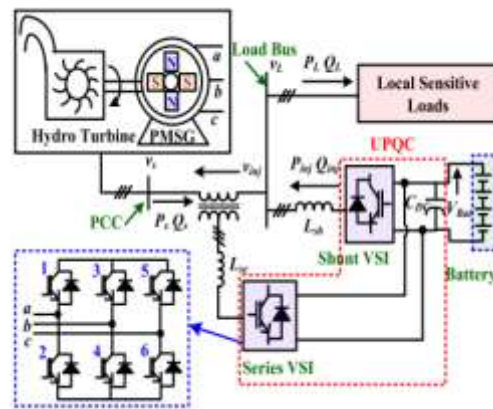

Standalone hydroelectric system integrated UPQC.

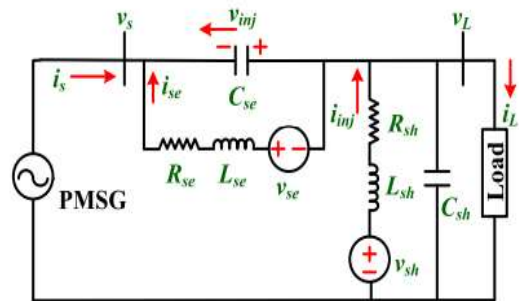

Single phase equivalent diagram of standalone hydroelectric system integrated UPQC.

Not only that, however Fig. 2 shows a simplified single-phase equivalent diagram of UPQC, with vs and is the source voltages and currents, and vL and iL the weight voltages and currents, respectively. The series compensator, denoted as vse and represented by means of the version u1, is used right here. Losses in the LC filter are denoted as Lse, Rse, and Cse, whereas VDC and

the injected voltage are denoted as  $v_{inj}$ . In evaluation,  $u_{2.VDC}$ ,  $L_{sh}$ , and  $R_{sh}$  constitute the filter out's losses and the shunt compensator ( $v_{sh}$ ). The  $i_{sh}$  represents the injected cutting-edge used for shunt reimbursement to eliminate the effect of the nonlinear load.

To similarly highlight distinctions in topology and its traits, Table I consists of a contrast of the applicable literature. Some of the matters that the provided work has contributed to are as follows.

1. A 3-section hydro-driven PMSG-battery backed device is prepared with an MPC algorithm to eradicate PQ troubles because of nonlinear hundreds and imbalanced loading. Thus, the source currents need to be balanced and sinusoidal, with a complete harmonic distortion (THD) that doesn't exceed the constraints set via the IEEE-519 preferred.
2. The MPC technique removes the want for a complete of PI or PR controllers in conventional algorithms. At harmonic frequencies, PR controllers provide limitless gain, however their performance drops off sharply as the frequency adjustments.
3. The integration of frequency control with shunt VSI control ensures a constant pace and frequency of generated voltage.
4. The load terminal voltages amplitudes continue to be regular at their rated values despite the fact that the voltage generated with the aid of the PMSG is decrease than its rated voltage. This is because the series VSI of the UPQC injects the perfect voltage, mitigating the voltage law problem. This design achieves consistent strength output and makes the device resilient against unbalanced or nonlinear loads, voltage dips, battery draining or charging, and other anomalies.
5. Voltage control is completed via series VSI, now not shunt VSI. When operating at team spirit pf, this minimises losses while

drawing reactive energy from the source. By creating an accurate MATLAB simulation model, the UPPC incorporated hydropower producing gadget primarily based on PMSG is examined beneath special scenarios. The produced prototype is in addition examined below various working situations to make sure its accuracy.

### 3. Control strategy based on MPC

Figure three shows the model predictive manage system in movement in a standalone hydropower device based totally on UPQC. This device draws three-segment AC electricity from a permanent magnet synchronous gadget. The shunt and collection VSIs of UPQC are each managed by means of MPC. By connecting a battery throughout the DC bus of the UPQC, the voltage throughout it's miles saved steady. Improving the voltage and modern-day satisfactory at each the weight and supply terminals is accomplished concurrently the usage of the MPC manipulate for UPQC. Part one in every of this control method includes UPQC modelling and nation variable prediction. Part is the MPC control approach. Part three is the development of reference indicators. Part 4 is the technology of finest switching pulses.

Predicting State Variables and Modelling UPQC A) Eliminating PWM manage and various comments loops the use of MPC is one reason of employing the version predictive controller. B) Adding clear out dynamics permits it to control the direct output voltage of the PCC factor. This MPC manipulate also does away with the need for PI controllers and tweaking them. The UPQC dynamic equations that recall

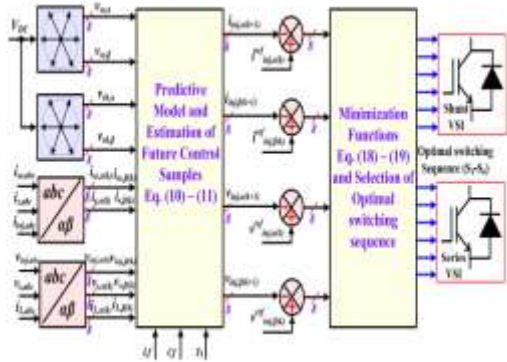

Schematic diagram of estimation optimal switching sequence with model predictive control

**A. Model Predictive Control Approach**

Figure three is a schematic of the control algorithms for collection and shunt VSIs, and this phase describes them. By receiving their reference values as inputs, this control offers VSI the greatest switching it desires to create the injected voltage and cutting-edge alerts which can be supposed. Then, on the (okay+1) moment, the use of the Ts pattern time, we can also explicit a discretised version of(7) as

$$x(k + 1) = A_d x(k) + B_{1d} u(k) + B_{2d} z(k)$$

The discretised types of the A, B1, and B2 matrices are represented by using the matrices Ad, b1d, and b2d, and the sampling second is denoted by using

$$A_d = e^{AT_s}, B_{1d} = \int_0^{T_s} e^{A\tau} B_1 d\tau, B_{2d} = \int_0^{T_s} e^{A\tau} B_2 d\tau$$

If the pattern time (Ts) is brief, an estimate may be made with the aid of assuming that eATs is approximately equal to I plus ATs. The intended outcomes of the injected voltages  $v_{inj}(ok + 1)$  and currents  $i_{inj}(k + 1)$  are proven within the  $\alpha\beta$  frame.

**4. MATLAB model and results**

**Proposed model:**

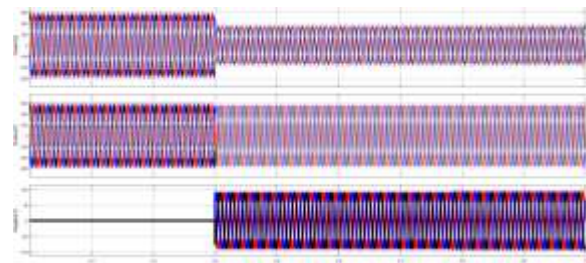
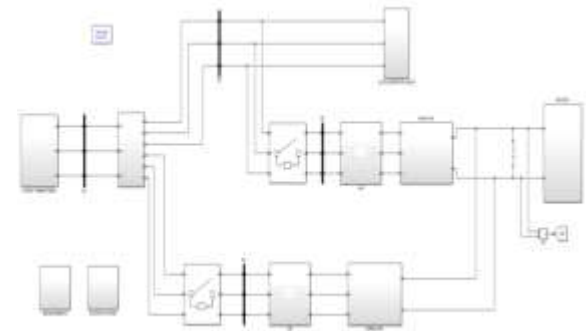

Performance of standalone hydroelectric based PMSG system without and with integration of UPQC. (a)  $v_s, abc, v_L, abc, v_{inj}, anc, i_L, abc, i_s, abc, i_{inj}, abc$

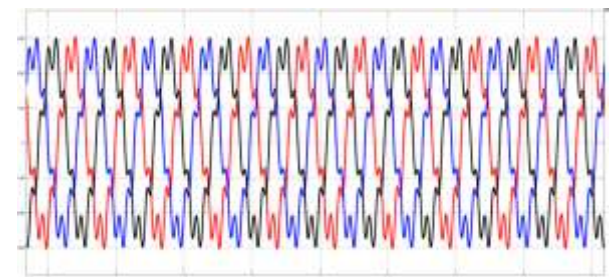

VLabc(Three phase load voltages)

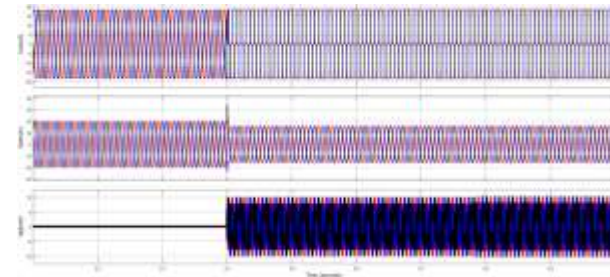

Load currents, Source currents and Injected Currents

**Dynamic performance**

Efficiency in a Changing Work Environment For the reason of assessing the dynamics of

unbalanced loading, the effects of the hardware validation of the UPQC incorporated standalone gadget were proven in Figs. 10(a-b) during the 'a' phase of trying out. See Figures 10(a-b) for voltage waveforms among phases 'a' and 'b' (vs,ab), modern-day in the 'a' section of the burden ( $i_{L,a}$ ), source currents in section 'a' ( $i_{s,a}$ ), and section 'b' ( $i_{s,b}$ ). We get rid of the load from section 'a' to examine how the gadget performs when the load is unbalanced. The balanced nature of the machine loading is shown with the aid of the equal energy demand in all 3 levels proper before the load separation. Because shunt VSI compensates, the generator currents are balanced and sinusoidal as properly.

As seen in Figure 10(a), the produced currents stay distortion-loose, balanced, and sinusoidal due to the fact the manner of providing compensating present day is maintained even when one segment of the load is disconnected. Whilst may be visible in Figure 10(b), this results in advanced PQs of the produced currents when the burden is reconnected to the network. There isn't any section distinction among the supply voltage and modern, as proven in Figs. 10(a-b), suggesting that the generator terminals have cohesion pf. When used together with battery storage, UPQC improves the energy first-rate of standalone hydropower based PMSG systems working beneath unbalanced loading situations. The gadget's dynamic overall performance is proven in Figures eleven(a-b) at a technology voltage beneath its rated fee. You can see the line voltages across the weight ( $v_{L,ab}$ ), the supply modern ( $i_{s,a}$ ), the injected voltage to accurate for voltage sag ( $v_{inj,a}$ ), and the source facet voltages (vs,ab) in Fig. Eleven(a). A distortion-free, sinusoidal supply modern-day at team spirit pf is executed while the shunt VSI injects the currents needed to accurate for harmonics and abnormalities caused by nonlinear loads, as proven in Figure 11 (a). Figure eleven(b) indicates the impact of the load's nonlinear behaviour on the load modern.

The voltages implemented to the load, as proven in Figures 11(a) and (b), are sinusoidal and saved at a regular importance, just as wanted.

This is because of the reality that series VSI injects voltages that are appropriate for keeping distortion-unfastened and chosen value load voltages. Noteworthy details are proven inside the determine. Performances of the Steady State Voltage Dip (C) The overall performance of the battery and the UPQC included standalone based PMSG gadget are tested in Figs. 12(a-b) for the duration of the generating voltage lower. Here, the regular state waveforms are acquired using a four-channel energy analyser made by way of HIOKI. The indicators and their values for the road voltage among lines 'a' and 'b' (vs,ab) and the supply voltage among lines 'b' and 'c' (vs,bc) in channel 2—with an rms value of 172.84 V—are proven in voltage window channel 1 of Fig. 12(a). Line voltages at load in levels 'a' and 'b' ( $v_{L,ab}$ ) and 'b-c' ( $v_{L,ab}$ ) in channels three and 4, respectively, with their rms values near the goal degree (220 V). Figure 12(b) additionally indicates balanced load voltages that are as an alternative close to to the goal price. Fig. 12(b) suggests the current home windows for channels 1-4, which display the waveforms and root-mean-rectangular values of the phase 'a' source cutting-edge ( $i_{s,a}$ ), section 'b' source current ( $i_{s,b}$ ), and section 'a' and 'b' load currents ( $i_{L,a}$  and  $i_{L,b}$ ), respectively. In order to prevent distortion, the contemporary pulled from the generator is sinusoidal and has the same segment because the voltage at the generator terminals. To counteract the nonlinearity of the load, shunt VSI injects harmonics and resources reactive electricity. Injecting a voltage of enough size to maintain the importance of the crucial load terminal voltage at its rated price and concurrently freeing the generator cutting-edge of harmonics, the series VSI of UPQC eliminates the voltage drop of the generator (because of the decrease in PMSG produced voltage). Performance indicators showing PQ

development of the standalone device's produced modern and load terminal voltages are shown in Fig. 12(b). Urms1, 2 and three represent the burden terminal line voltages rms, while Uthd1, 2 and 3 constitute the corresponding general harmonic distortion (THD) values. Irms1, Irms2, and Irms3 denote the produced currents rms values, at the same time as Ithd1, Ithd2, and Ithd3 denote their general harmonic distortions (THDs). There isn't any deviation from the IEEE wellknown within the total harmonic distortion (THD) of the produced modern-day or the essential load voltage. In addition to preserving a steady crucial load voltage at its distinct cost.

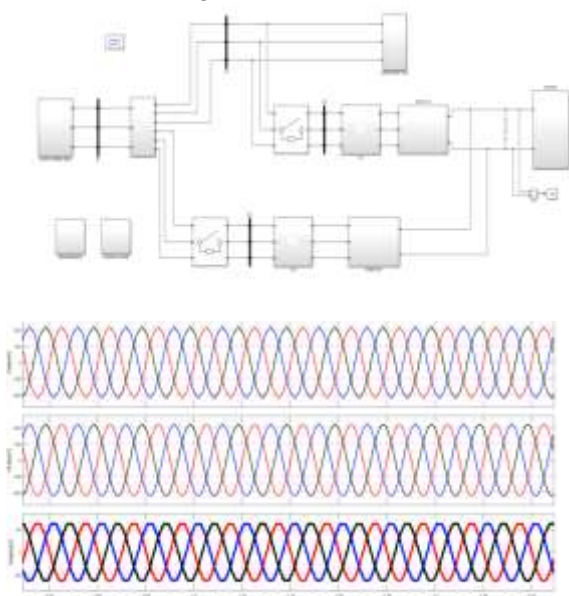

Load voltage, Source voltage and Injected voltage

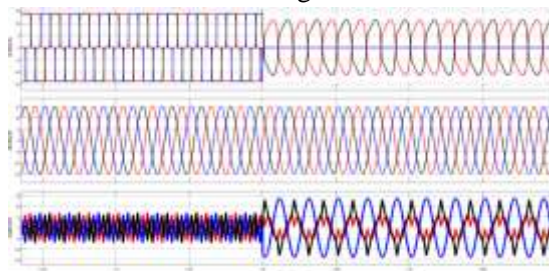

Load currents, Source currents and Injected Currents

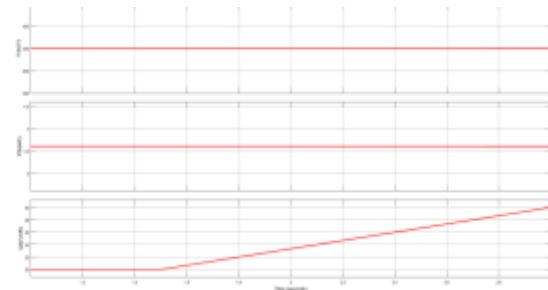

Battery DCLink voltage, constant power at generator end, negligible reactive power at generator end

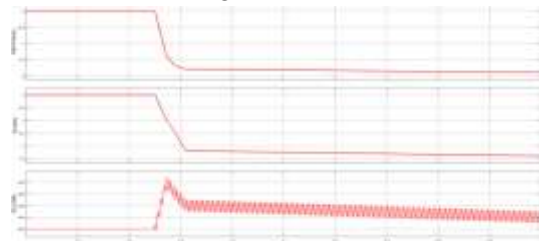

THD(total harmonic values) VALUS

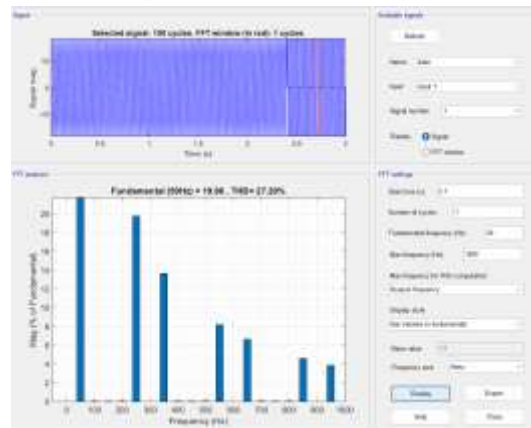

ILabc( Load Current THD Values)

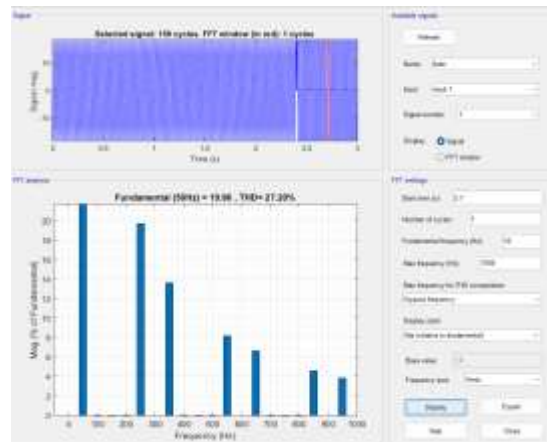

IS abc(Source Current THD Values).

## 5. Conclusions

To accurate for harmonics in present day and voltage, voltage dips because of changes within the load and the presence of the PMSG's source impedance, reactive energy, load unbalance, and different troubles, model predictive manipulate has been used to modify a UPQC system that contains a PMSG as an alternating modern (AC) source this is powered through a battery. During both static and dynamic sports, the UPQC that consists of PMSG as an AC supply and is powered by a battery has shown to be each effective and dependable, significantly enhancing PQs.

By preserving the burden terminal voltage at its rated fee beneath diverse scenarios (e.G., generator voltage drop, load disconnection or reconnections), the take a look at outcomes reveal accurate performance for critical masses (whether or not linear or nonlinear). I. The work is balanced and harmonics free; (ii) the generator cutting-edge and cargo terminal voltage THDs are inside the allowable limits of IEEE popular 519; (iii) typical machine losses are reduced for decrease magnitudes of generated voltage; and (iv) the generator is operated at advanced pf (close to team spirit cost), with the load terminal voltage significance maintained at rated.

A prototype for improving the power great of independent hydroelectric energy production the use of PMSG and a battery has been confirmed, and the effects are accurate and efficient.

## References

[1] A. Bharate, P. K. Ray, and A. Ghosh, "Hardware design for implementation of energy management in a solar-interfaced DC microgrid," *IEEE Trans. Consum. Electron.*, vol. 69, no. 3, pp. 343–352, Aug. 2023, doi: 10.1109/TCE.2023.3243637.

[2] M. Fatu, F. Blaabjerg, and I. Boldea, "Grid to standalone transition motion-sensorless dual-inverter control of PMSG with asymmetrical grid voltage sags and harmonics filtering," *IEEE*

*Trans. Power Electron.*, vol. 29, no. 7, pp. 3463–3472, Jul. 2014.

[3] X. Tong, D. Ma, R. Wang, X. Xie, and H. Zhang, "Dynamic event-triggered-based integral reinforcement learning algorithm for frequency control of microgrid with stochastic uncertainty," *IEEE Trans. Consum. Electron.*, vol. 29, no. 7, pp. 3463–3472, Jul. 2014, doi: 10.1109/TCE.2023.3241684.

[4] R. Sharma, A. Zakerian, and M. Karimi-Ghartemani, "Local controller for an autonomous grid-supportive battery energy storage system," *IEEE Trans. Power Electron.*, vol. 37, no. 2, pp. 2191–2202, Feb. 2022.

[5] Z. Zhang, P. Wang, P. Jiang, F. Gao, L. Fu, and Z. Liu, "Robust control method of grid-connected inverters with enhanced current quality while connected to a weak power grid," *IEEE Trans. Power Electron.*, vol. 37, no. 6, pp. 7263–7274, Jun. 2022.

[6] D. Das, B. Singh, and S. Mishra, "Grid interactive solar PV and battery operated air conditioning system: Energy management and power quality improvement," *IEEE Trans. Consum. Electron.*, vol. 69, no. 2, pp. 109–117, May 2023.

[7] B. Long et al., "Noninteger lexicographic-optimization-based sequential model-predictive fault-tolerant control of T-type shunt active power filter," *IEEE Trans. Power Electron.*, vol. 37, no. 6, pp. 7169–7184, Jun. 2022.

[8] G. S. Chawda, A. G. Shaik, O. P. Mahela, and S. Padmanaban, "Performance improvement of weak grid-connected wind energy system using FLSRF-controlled DSTATCOM," *IEEE Trans. Ind. Electron.*, vol. 70, no. 2, pp. 1565–1575, Feb. 2023.

[9] R. H. Yang et al., "A battery-energy-storage-based DC dynamic voltage restorer for DC renewable power protection," *IEEE Trans. Sustain. Energy*, vol. 13, no. 3, pp. 1707–1721, Jul. 2022.

[10] X. Y. Chen et al., "An SMES-based current-fed transformerless series voltage

restorer for DC-load protection,” IEEE Trans. Power Electron., vol. 36, no. 9, pp. 9698–9703, Sep. 2021.

[11] S. A. O. da Silva, L. B. G. Campanhol, G. M. Pelz, and V. de Souza, “Comparative performance analysis involving a three-phase UPQC operating with conventional and dual/inverted power-line conditioning strategies,” IEEE Trans. Power Electron., vol. 35, no. 11, pp. 11652–11665, Nov. 2020.

[12] W. Jia, Q. Guo, C. Tu, F. Jiang, L. Wang, and Y. Hou, “Improved single-phase UPQC with integrating auxiliary capacitor for power rating reduction,” IEEE Trans. Ind. Electron., vol. 70, no. 9, pp. 9091–9102, Sep. 2023.

[13] N. Khosravi, S. Echalih, Z. Hekss, R. Baghbanzadeh, M. Messaoudi, and M. Shahideipour, “A new approach to enhance the operation of M-UPQC proportional-integral multi-resonant controller based on the optimization methods for a stand-alone AC microgrid,” IEEE Trans. Power Electron., vol. 38, no. 3, pp. 3765–3774, Mar. 2023.

[14] N. Zanib, M. Batool, S. Riaz, and F. Nawaz, “Performance analysis of renewable energy based distributed generation system using ANN tuned UPQC,” IEEE Access, vol. 10, pp. 110034–110049, 2022.

[15] K. Srilakshmi et al., “Design of soccer league optimization based hybrid controller for solar-battery integrated UPQC,” IEEE Access, vol. 10, pp. 107116–107136, 2022.

[16] C. Karasala and S. K. Ganjikunta, “An adaptive DC-link voltage control of a multifunctional SPV grid-connected VSI for switching loss reduction,” IEEE Trans. Ind. Electron., vol. 69, no. 12, pp. 12946–12956, Dec. 2022.

[17] D. Schuetz, “Space vector modulated model predictive control for gridtied converters,” IEEE Trans. Ind. Informat., vol. 19, no. 1, pp. 414–425, Jan. 2023.

[18] IEEE Recommended Practice and Requirements for Harmonic Control in Electric

Power Systems, IEEE Standard 519–2022, Jun. 2022.

[19] C. D. Sanjenbam, B. Singh, and S. Devassy, “Modified generalised integrator based control strategy for solar PV fed UPQC enabling power quality improvement,” IET Gener. Transm. Distrib., vol. 14, no. 16, pp. 3127–3138, 2020.

[20] B. Singh, A. Chandra, and K. Al-Haddad, Power Quality: Problems and Mitigation Techniques. London, U.K.: Wiley, 2015.